

# ADC1443D series

Dual 14-bit ADC; 125, 160 or 185 Msps; JESD204A/B serial outputs

Rev. 4.4 — 6 June 2014

Product data sheet

## 1. General description

The ADC1443D is a dual channel 14-bit Analog-to-Digital Converter (ADC) with JESD204B interface (which is backward compatible with the JESD204A interface) optimized for high dynamic performance and low power consumption at sample rates up to 185 Msps. Pipelined architecture and output error correction guarantee zero missing codes over the entire operating range.

Supplied from a single 1.8 V source, the ADC1443D has JESD204B serial outputs over a configurable number of lanes (1 or 2). Multiple Device Synchronization (MDS) allows sample-accurate synchronization of the data outputs of multiple ADC devices. It guarantees a maximum skew of one clock period between as many as 16 output lanes from up to eight ADC1443D devices.

An integrated Serial Peripheral Interface (SPI) allows easy configuration of the ADC. The device also includes a programmable full-scale to allow a flexible input voltage range of 1 V (p-p) to 2 V (p-p).

With an analog bandwidth from the baseband to input frequencies of up to 1 GHz (typical), the ADC1443D is ideal for use in undersampled multi-carrier, multistandard communication system applications.

## 2. Features and benefits

- Dual channel 14-bit resolution ADC
- Sampling rate up to 185 Msps
- JESD204B Device Subclass 0, 1 and 2 with harmonic clocking and deterministic latency support
- ADC Multiple Device Synchronization (MDS)
- Two JESD204B serial output lanes, up to 5 Gbps typical
- Single 1.8 V supply
- Offset binary, two's complement and Gray output data
- SNR = 70.6 dBFS (typical);  $f_s = 154$  Msps;  $f_i = 190$  MHz
- SFDR = 86 dBc (typical);  $f_s = 154$  Msps;  $f_i = 190$  MHz
- IMD3 = 88 dBc (typical);  $f_s = 154$  Msps;  $f_{i1} = 188.5$  MHz;  $f_{i2} = 191.5$  MHz
- Analog input bandwidth of 1 GHz (typical)
- Pin to pin compatible with ADC1413D series
- Typical power dissipation = 0.8 W;  $f_s = 154$  Msps
- Power-down and sleep modes



- Flexible input voltage range from 1 V (p-p) to 2 V (p-p) by 1 dB steps
- Clock input divider from 1 to 8 supports harmonic clocking
- Duty Cycle Stabilizer (DCS)
- Industrial temperature range from  $-40\text{ }^{\circ}\text{C}$  to  $+85\text{ }^{\circ}\text{C}$
- Serial Peripheral Interface (SPI) for configuration control and status monitoring
- VFQFPN56 package;  $8 \times 8\text{ mm}$

### 3. Applications

- Wireless infrastructure: LTE, TD-LTE, WiMAX, MC-GSM, CDMA, WCDMA, TD-SCDMA
- Software defined radio
- Medical non-invasive scanners
- Scientific particle detectors
- Microwave backhaul transceivers
- Aerospace and defense communications and radar systems
- Industrial signal analysis instruments
- General-purpose high-speed applications

### 4. Ordering information

Table 1. Ordering information

Type number	$f_s$ (Msps)	Package		
		Name	Description	Version
ADC1443D200HD	185	VFQFPN	plastic thermal enhanced low profile quad flat package; no leads; 56 terminals; resin based; body $8 \times 8 \times 1.35\text{ mm}$	PSC-4449
ADC1443D160HD	160	VFQFPN	plastic thermal enhanced low profile quad flat package; no leads; 56 terminals; resin based; body $8 \times 8 \times 1.35\text{ mm}$	PSC-4449
ADC1443D125HD	125	VFQFPN	plastic thermal enhanced low profile quad flat package; no leads; 56 terminals; resin based; body $8 \times 8 \times 1.35\text{ mm}$	PSC-4449

## 5. Block diagram

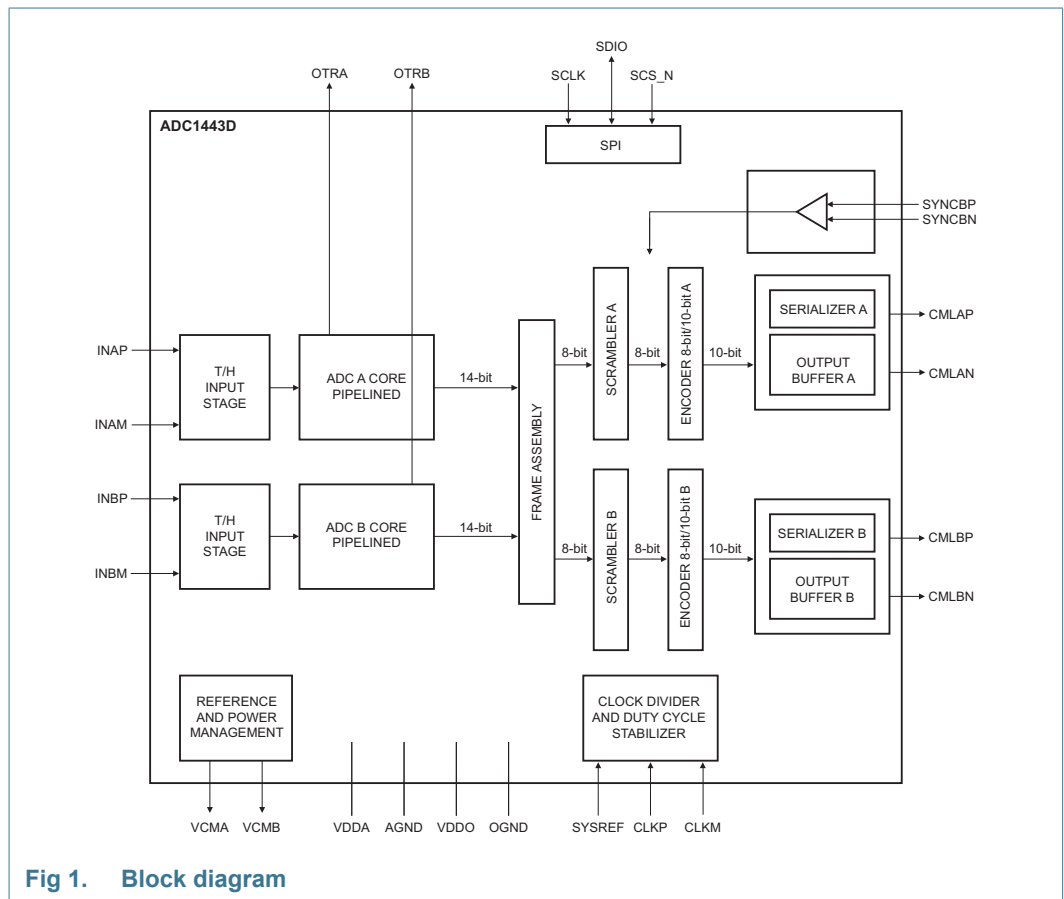
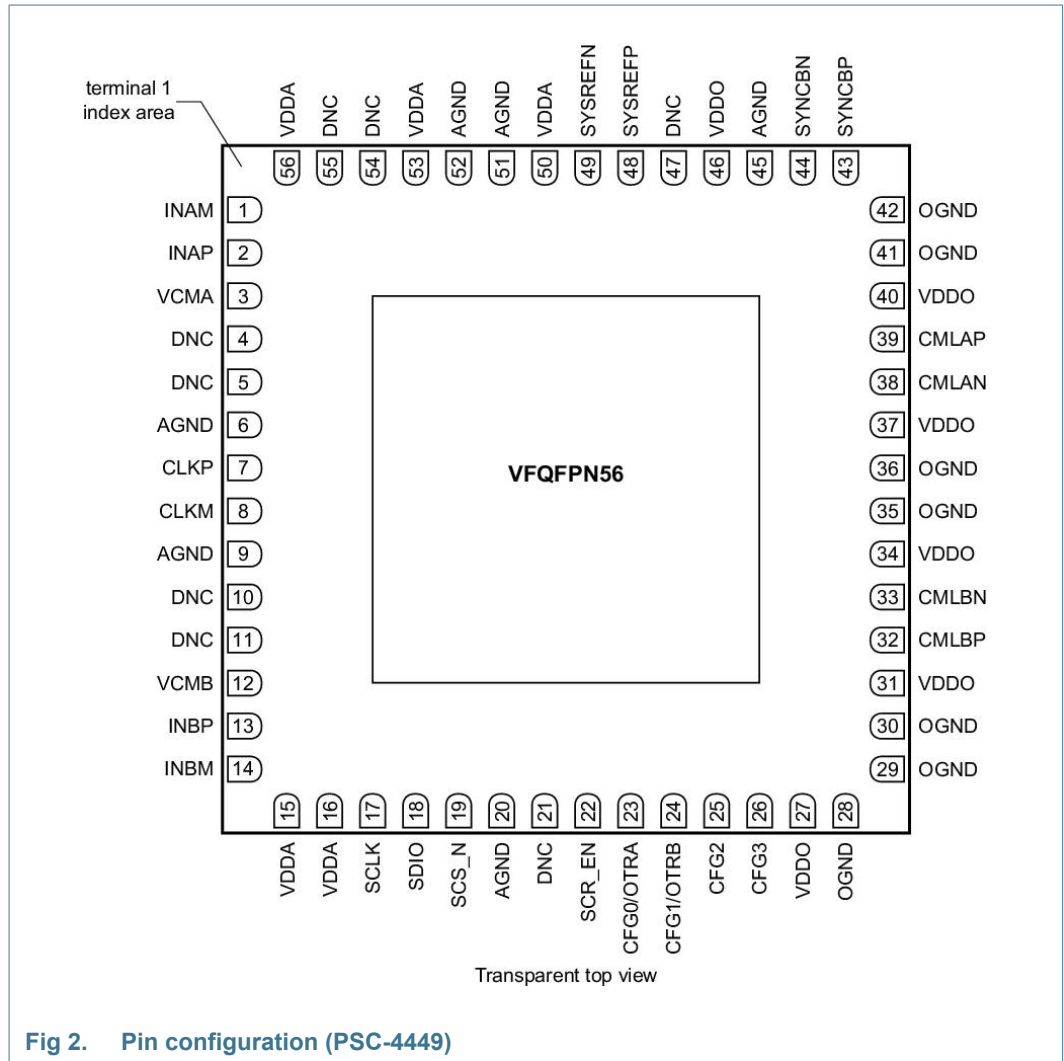

Fig 1. Block diagram

## 6. Pinning information

### 6.1 Pinning



## 6.2 Pin description

Table 2. Pin description

Symbol	Pin	Type <sup>[1]</sup>	Description
INAM	1	I	channel A complementary analog input
INAP	2	I	channel A analog input
VCMA	3	O	channel A output common voltage
DNC	4	-	do not connect
DNC	5	-	do not connect
AGND	6	G	analog ground
CLKP	7	I	clock input
CLKN	8	I	complementary clock input
AGND	9	G	analog ground
DNC	10	-	do not connect
DNC	11	-	do not connect
VCMB	12	O	channel B output common voltage
INBP	13	I	channel B analog input
INBM	14	I	channel B complementary analog input
VDDA	15	P	analog power supply
VDDA	16	P	analog power supply
SCLK	17	I	SPI clock. Internally connected to 50k $\Omega$ pull-down
SDIO	18	I/O	SPI data IO. Internally connected to 50k $\Omega$ pull-down (when used as input)
SCS_N	19	I	SPI chip select. Internally connected to 50k $\Omega$ pull-up
AGND	20	G	analog ground
DNC	21	-	do not connect
SCR_EN	22	I	scrambler enable. Internally connected to 50k $\Omega$ pull-up
CFG0/OTRA	23	I/O	configuration pin 0/OuT of Range A (OTRA). Internally connected to 50k $\Omega$ pull-down (when used as input)
CFG1/OTRB	24	I/O	configuration pin 1/OuT of Range B (OTRB). Internally connected to 50k $\Omega$ pull-down (when used as input)
CFG2	25	I/O	configuration pin 2. Internally connected to 50k $\Omega$ pull-down (when used as input)
CFG3	26	I/O	configuration pin 3. Internally connected to 50k $\Omega$ pull-down (when used as input)
VDDO	27	P	digital output power supply
AGND	28	G	analog ground
OGND	29	G	digital output ground
OGND	30	G	digital output ground
VDDO	31	P	digital output power supply
CMLBP	32	O	channel B output
CMLBN	33	O	channel B complementary output
VDDO	34	P	digital output power supply
OGND	35	G	digital output ground
OGND	36	G	digital output ground

Table 2. Pin description ...continued

Symbol	Pin	Type <sup>[1]</sup>	Description
VDDO	37	P	digital output power supply
CMLAN	38	O	channel A complementary output
CMLAP	39	O	channel A output
VDDO	40	P	digital output power supply
OGND	41	G	digital output ground
OGND	42	G	digital output ground
SYNCBP	43	I	JESD204B SYNC synchronization signal from receiver
SYNCBN	44	I	complementary SYNC from receiver
AGND	45	G	analog ground
VDDO	46	P	digital output power supply
DNC	47	-	do not connect
SYSREFP	48	I	positive clock synchronization
SYSREFN	49	I	negative clock synchronization
VDDA	50	P	analog power supply
AGND	51	G	analog ground
AGND	52	G	analog ground
VDDA	53	P	analog power supply
DNC	54	-	do not connect
DNC	55	-	do not connect
VDDA	56	P	analog power supply
AGND	EXP	G	Expose PAD

[1] P: power supply; G: ground; I: input; O: output; I/O: input/output.

### 6.2.1 Start-up Configuration

Because the maximum sampling clock of the ADC1443D is 200 Msps, care should be taken in case of harmonic clocking. If the input clock frequency is higher than 200 MHz, the clock divider must be set before providing the clock.

In order to avoid any issue, it is recommended to start the device in power-down mode by setting the configuration pins to logic level '1' (see [Table 19](#)). This can be done by adding for example a 1 k $\Omega$  pull-up resistor on CFG0, CFG1, CFG2 and CFG3.

When the power supplies are set, the divider can be programmed by the use of the SPI registers. Then the device is powered on and the JESD204B configuration is set by the use of the SPI registers (bits CFG\_SETUP[3:0] in [Table 42](#)).

## 7. Limiting values

**Table 3. Limiting values**

In accordance with the Absolute Maximum Rating System (IEC 60134).

Symbol	Parameter	Conditions	Min	Max	Unit
$V_{DDA}$	analog supply voltage		-0.3	+2.1	V
$V_{DDO}$	output supply voltage		-0.3	+2.1	V
$\Delta V_{DD}$	supply voltage difference	$V_{DDA} - V_{DDO}$	-0.8	+0.8	V
$V_I$	input voltage	pins INP, INM, CLKP and CLKM; referenced to AGND	-0.3	$V_{DDA} + 0.3$	V
		pins OTR, SCS_N, SDIO, SCLK, CFG, SCR_EN, SYSREFP, SYSREFN, SYNCBP, and SYNCBN; referenced to AGND	-0.3	$V_{DDO} + 0.3$	V
$V_O$	output voltage	pin VCM; referenced to AGND	-0.3	$V_{DDA} + 0.3$	V
		pins CMLP, and CMLN; referenced to OGND	-0.3	$V_{DDO} + 0.3$	V
$T_{stg}$	storage temperature		-55	+125	°C
$T_{amb}$	ambient temperature		-40	+85	°C
$T_j$	junction temperature		-	125	°C

## 8. Thermal characteristics

**Table 4. Thermal characteristics**

Symbol	Parameter	Conditions	Typ	Unit
$R_{th(j-a)}$	thermal resistance from junction to ambient	66 vias	[1] 22.7	K/W
$R_{th(j-c)}$	thermal resistance from junction to case	66 vias	[1] 9.3	K/W

[1] In compliance with JEDEC test board, in free air.

## 9. Static characteristics

**Table 5. Static characteristics**<sup>[1]</sup>

Symbol	Parameter	Conditions	Min	Typ	Max	Unit
<b>Supplies</b>						
$V_{DDA}$	analog supply voltage		1.7	1.8	1.9	V
$V_{DDO}$	output supply voltage		1.7	1.8	1.9	V
$I_{DDA}$	analog supply current	$f_s = 185$ Msps; $f_i = 190$ MHz	-	321	391	mA
$I_{DDO}$	output supply current	$f_s = 185$ Msps; $f_i = 190$ MHz	-	169	198	mA

Table 5. Static characteristics<sup>[1]</sup> ...continued

Symbol	Parameter	Conditions	Min	Typ	Max	Unit
P <sub>tot</sub>	total power dissipation	f <sub>i</sub> = 190 MHz				
		ADC1443D125; f <sub>s</sub> = 125 Msps	-	0.71	0.9	W
		ADC1443D160; f <sub>s</sub> = 154 Msps	-	0.8	1.0	W
		ADC1443D200; f <sub>s</sub> = 185 Msps	-	0.9	1.1	W
		Power-down mode	-	10	-	mW
	Sleep mode	-	115	-	mW	
<b>Clock inputs: pins CLKP and CLKM (AC-coupled; peak-to-peak)</b>						
V <sub>i(clk)</sub>	clock input voltage	LVPECL	-	±0.8	-	V
		LVDS	-	±0.35	-	V
		SINE differential	±0.5	±1.25	-	V
		LVC MOS single	-	±0.6	-	V
C <sub>i</sub>	input capacitance		-	1.2	-	pF
<b>Logic inputs</b>						
I <sub>IL</sub>	LOW-level input current	absolute value	-	30	-	μA
I <sub>IH</sub>	HIGH-level input current	absolute value	-	70	-	μA
C <sub>i</sub>	input capacitance		-	1.2	-	pF
<b>pins SYSREFP, SYSREFN, SYNCBP, and SYNCBN (Differential Pins)</b>						
V <sub>i(cm)</sub>	common-mode input voltage		0.925	1.2	1.475	V
V <sub>i(dif)</sub>	differential input voltage		0.2	0.7	-	V
<b>pins SCS_N, SDIO, SCLK, SCR_EN, CFG, SYNCBP and SYSREFP (Single Ended)</b>						
V <sub>IL</sub>	LOW-level input voltage		0	-	0.3V <sub>DDO</sub>	V
V <sub>IH</sub>	HIGH-level input voltage		0.7V <sub>DDO</sub>	-	V <sub>DDO</sub>	V
<b>Logic output: pins OTRA, OTRB and SDIO</b>						
V <sub>OL</sub>	LOW-level output voltage		0	-	0.2	V
V <sub>OH</sub>	HIGH-level output voltage		V <sub>DDO</sub> -0.2	-	V <sub>DDO</sub>	V
<b>Digital outputs: pins CMLAP, CMLAN, CMLBP, and CMLBN</b>						
V <sub>O(cm)</sub>	common-mode output voltage	default current	-	1.4	-	V
V <sub>O(dif)</sub>	differential output voltage	default current; peak-to-peak	-	800	-	mV
<b>Analog inputs: pins INP and INM</b>						
I <sub>i</sub>	input current		-	±5	-	μA
R <sub>i</sub>	input resistance	f <sub>i</sub> = 190 MHz	-	400	-	Ω
C <sub>i</sub>	input capacitance	f <sub>i</sub> = 190 MHz	-	5	-	pF
V <sub>i(cm)</sub>	common-mode input voltage	V <sub>INP</sub> = V <sub>INM</sub> ; T <sub>amb</sub> = 25 °C	0.8	0.9	1.0	V
B <sub>i</sub>	input bandwidth		-	1	-	GHz
V <sub>i(dif)</sub>	differential input voltage	peak-to-peak; full-scale	1	-	2	V
<b>Common-mode output voltage: pins VCMA and VCMB</b>						
V <sub>O(cm)</sub>	common-mode output voltage	I <sub>O(cm)</sub> = 1mA	-	0.9	-	V
I <sub>O(cm)</sub>	common-mode output current	T <sub>amb</sub> = 25 °C	-	-	1	mA



Table 5. Static characteristics<sup>[1]</sup> ...continued

Symbol	Parameter	Conditions	Min	Typ	Max	Unit
<b>Accuracy</b>						
INL	integral non-linearity	$f_s = 153.6$ Msps; $f_i = 4.43$ MHz	-	$\pm 1.43$	$\pm 5.2$	LSB
DNL	differential non-linearity	$f_s = 185$ Msps; $f_i = 4.43$ MHz; guaranteed no missing codes				
		Minimum typical value	-0.49	-0.30		LSB
		Maximum typical value		+0.25	+0.37	LSB
$E_{\text{offset}}$	offset error		-20	-	+20	mV
$E_G$	gain error	full-scale	-	4.1	-	%
$M_{G(\text{CTC})}$	channel-to-channel gain matching		-	3.5	-	%
OS	Offset Spur	measured at FS/2 with FS=160Msps		-82		dBc
<b>Supply</b>						
PSRR	power supply rejection ratio	100 mV (p-p) on $V_{\text{DDA}}$ , 0.5 to 2MHz	-	-47	-	dB

[1] Typical values measured at  $V_{\text{DDA}} = V_{\text{DDO}} = 1.8$  V;  $T_{\text{amb}} = 25$  °C. Minimum and maximum values are across the full temperature range  $T_{\text{amb}} = -40$  °C to  $+85$  °C at  $V_{\text{DDA}} = V_{\text{DDO}} = 1.8$  V;  $V_{\text{I}(\text{dif})} = 2$  V;  $V_{\text{INP}} - V_{\text{INM}} = -1$  dBFS; unless otherwise specified.

## 10. Dynamic characteristics

### 10.1 Dynamic characteristics

Table 6. Dynamic characteristics<sup>[1]</sup>

Symbol	Parameter	Conditions	ADC1443D125 ( $f_s = 125$ Msps)			ADC1443D160 ( $f_s = 154$ Msps)			ADC1443D200 ( $f_s = 185$ Msps)			Unit
			Min	Typ	Max	Min	Typ	Max	Min	Typ	Max	
$\alpha_{2H}$	second harmonic level	$f_i = 5$ MHz	-	-87	-	-	-84	-	-	-85	-	dBc
		$f_i = 70$ MHz	-	-85	-	-	-82	-	-	-75	-	dBc
		$f_i = 140$ MHz	-	-92	-	-	-85	-	-	-80	-	dBc
		$f_i = 170$ MHz	-	-83	-	-	-83	-	-	-87	-	dBc
		$f_i = 190$ MHz	-	-82	-	-	-86	-	-	-83	-	dBc
		$f_i = 230$ MHz	-	-78	-	-	-80	-	-	-86	-	dBc
$\alpha_{3H}$	third harmonic level	$f_i = 5$ MHz	-	-100	-	-	-88	-	-	-85	-	dBc
		$f_i = 70$ MHz	-	-97	-	-	-90	-	-	-81	-	dBc
		$f_i = 140$ MHz	-	-88	-	-	-89	-	-	-85	-	dBc
		$f_i = 170$ MHz	-	-94	-	-	-90	-	-	-83	-	dBc
		$f_i = 190$ MHz	-	-96	-	-	-87	-	-	-80	-	dBc
		$f_i = 230$ MHz	-	-95	-	-	-85	-	-	-80	-	dBc
SFDR	spurious-free dynamic range	$f_i = 5$ MHz	-	87	-	-	84	-	-	79	-	dBc
		$f_i = 70$ MHz	-	85	-	-	82	-	-	75	-	dBc
		$f_i = 140$ MHz	-	92	-	-	85	-	-	80	-	dBc
		$f_i = 170$ MHz	-	83	-	-	83	-	-	83	-	dBc
		$f_i = 190$ MHz	-	82	-	-	86	-	-	80	-	dBc
		$f_i = 230$ MHz	-	78	-	-	80	-	-	80	-	dBc
THD	total harmonic distortion	$f_i = 5$ MHz	-	-86.5	-	-	-82.3	-	-	-80	-	dBc
		$f_i = 70$ MHz	-	-84.2	-	-	-80	-	-	-72	-	dBc
		$f_i = 140$ MHz	-	-85.3	-	-	-82.8	-	-	-77	-	dBc
		$f_i = 170$ MHz	-	-81.8	-	-	-81.7	-	-	-80	-	dBc
		$f_i = 190$ MHz	-	-81.4	-	-	-81.9	-	-	-78	-	dBc
		$f_i = 230$ MHz	-	-77.5	-	-	-78.5	-	-	-78	-	dBc

Table 6. Dynamic characteristics<sup>[1]</sup> ...continued

Symbol	Parameter	Conditions	ADC1443D125 (f <sub>s</sub> = 125 Msps)			ADC1443D160 (f <sub>s</sub> = 154 Msps)			ADC1443D200 (f <sub>s</sub> = 185 Msps)			Unit
			Min	Typ	Max	Min	Typ	Max	Min	Typ	Max	
IMD3	third-order intermodulation distortion	f <sub>i1</sub> = 3.5 MHz; f <sub>i2</sub> = 6.5 MHz	-	91	-	-	90	-	-	85	-	dBc
		f <sub>i1</sub> = 68.5 MHz; f <sub>i2</sub> = 71.5 MHz	-	90	-	-	89	-	-	85	-	dBc
		f <sub>i1</sub> = 138.5 MHz; f <sub>i2</sub> = 141.5 MHz	-	89	-	-	88	-	-	84	-	dBc
		f <sub>i1</sub> = 168.5 MHz; f <sub>i2</sub> = 171.5 MHz	-	91	-	-	88	-	-	83	-	dBc
		f <sub>i1</sub> = 188.5 MHz; f <sub>i2</sub> = 191.5 MHz	-	88	-	-	87	-	-	87	-	dBc
		f <sub>i1</sub> = 228.5 MHz; f <sub>i2</sub> = 231.5 MHz	-	87	-	-	87	-	-	88	-	dBc
SNR	signal-to-noise ratio	f <sub>i</sub> = 5 MHz	-	72.6	-	-	71.9	-	-	68.8	-	dBFS
		f <sub>i</sub> = 70 MHz	-	72.4	-	-	71.7	-	-	68	-	dBFS
		f <sub>i</sub> = 140 MHz	-	72.1	-	-	71.3	-	-	68.3	-	dBFS
		f <sub>i</sub> = 170 MHz	-	71.6	-	-	70.8	-	-	68.5	-	dBFS
		f <sub>i</sub> = 190 MHz	-	71.2	-	-	70.6	-	-	68.5	-	dBFS
		f <sub>i</sub> = 230 MHz	-	70.6	-	-	70	-	-	67	-	dBFS
ENOB	effective number of bits	f <sub>i</sub> = 5 MHz	-	11.7	-	-	11.4	-	-	10.9	-	bit
		f <sub>i</sub> = 70 MHz	-	11.7	-	-	11.4	-	-	10.7	-	bit
		f <sub>i</sub> = 140 MHz	-	11.7	-	-	11.3	-	-	10.8	-	bit
		f <sub>i</sub> = 170 MHz	-	11.5	-	-	11.3	-	-	10.9	-	bit
		f <sub>i</sub> = 190 MHz	-	11.5	-	-	11.2	-	-	10.8	-	bit
		f <sub>i</sub> = 230 MHz	-	11.3	-	-	11.1	-	-	10.6	-	bit
α <sub>ct(ch)</sub>	channel crosstalk	f <sub>i</sub> = 140 MHz	-	95	-	-	95	-	-	92	-	dBc
		f <sub>i</sub> = 230 MHz	-	90	-	-	90	-	-	92	-	dBc

[1] Typical values measured at V<sub>DDA</sub> = V<sub>DDO</sub> = 1.8 V; T<sub>amb</sub> = 25 °C. Minimum and maximum values are across the full temperature range T<sub>amb</sub> = -40 °C to +85 °C at V<sub>DDA</sub> = V<sub>DDO</sub> = 1.8 V; V<sub>I(dif)</sub> = 2 V; V<sub>INP</sub> - V<sub>INM</sub> = -1 dBFS; unless otherwise specified.

## 10.2 Timing

### 10.2.1 Clock timing

**Table 7. Clock and digital output timing characteristics<sup>[1]</sup>**

Symbol	Parameter	Conditions	Min	Typ	Max	Unit
$t_{lat(data)}$	data latency time	F=1	54	-	55	clock cycles
		F=2	45.5	-	46	clock cycles
		F=4	41	-	41.25	clock cycles
$t_{wake}$	wake-up time	from Power-down mode	-	60	-	$\mu$ s
		from Sleep mode	-	54	-	$\mu$ s
<b>Clock timing</b>						
$f_s$	sampling rate	ADC1443D125	60	-	125	MHz
		ADC1443D160	125	-	160	MHz
		ADC1443D200	160	-	185	MHz
$f_{clk}$	clock frequency		60	-	800	MHz
$\delta_{clk}$	clock duty cycle		40	-	60	%

[1] Typical values measured at  $V_{DDA} = V_{DDO} = 1.8$  V;  $T_{amb} = 25$  °C. Minimum and maximum values are across the full temperature range  $T_{amb} = -40$  °C to  $85$  °C at  $V_{DDA} = V_{DDO} = 1.8$  V;  $V_{I(dif)} = 2$  V;  $V_{INP} - V_{INM} = -1$  dBFS; unless otherwise specified.

### 10.2.2 SYSREFP/N and SYNCBP/N timings

**Table 8. SYSREF timing**

Symbol	Parameter	Conditions	Min	Typ	Max	Unit
$t_{su}$	set-up time		0.5	-	-	ns
$t_h$	hold time		( $t_{clk}/2$ ) -0.5	-	-	ns

**Table 9. SYNCB timing**

Symbol	Parameter	Conditions	Min	Typ	Max	Unit
$t_{su}$	set-up time		0.75	-	-	ns
$t_h$	hold time		( $t_{clk}/2$ ) -0.25	-	-	ns

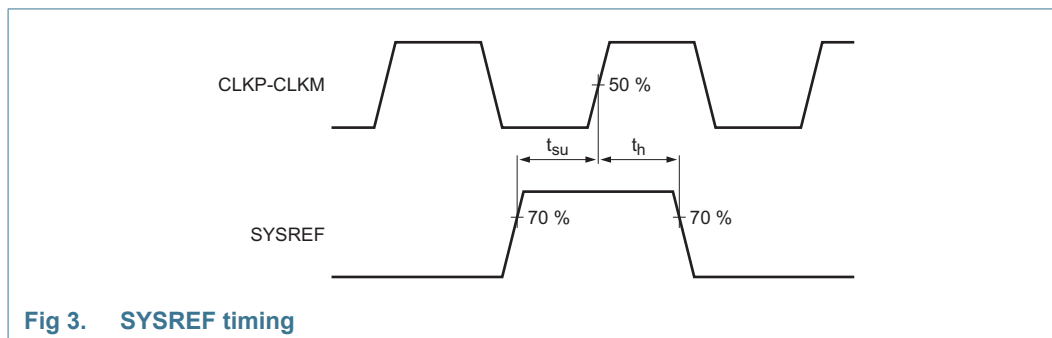

10.2.3 SPI timing

Table 10. SPI timing characteristics [1]

Symbol	Parameter	Conditions	Min	Typ	Max	Unit
$t_{w(SCLK)}$	SCLK pulse width		40	-	-	ns
$t_{w(SCLKH)}$	SCLK HIGH pulse width		16	-	-	ns
$t_{w(SCLKL)}$	SCLK LOW pulse width		16	-	-	ns
$t_{su}$	set-up time	SDIO to SCLK HIGH	5	-	-	ns
		SCS_N to SCLK HIGH	5	-	-	ns
$t_h$	hold time	SDIO to SCLK HIGH	2	-	-	ns
		SCS_N to SCLK HIGH	2	-	-	ns
$f_{clk}$	clock frequency		-	-	25	MHz

[1] Typical values measured at  $V_{DDA} = V_{DDO} = 1.8\text{ V}$ ;  $T_{amb} = 25\text{ }^\circ\text{C}$ . Minimum and maximum values are across the full temperature range  $T_{amb} = -40\text{ }^\circ\text{C}$  to  $+85\text{ }^\circ\text{C}$  at  $V_{DDA} = V_{DDO} = 1.8\text{ V}$

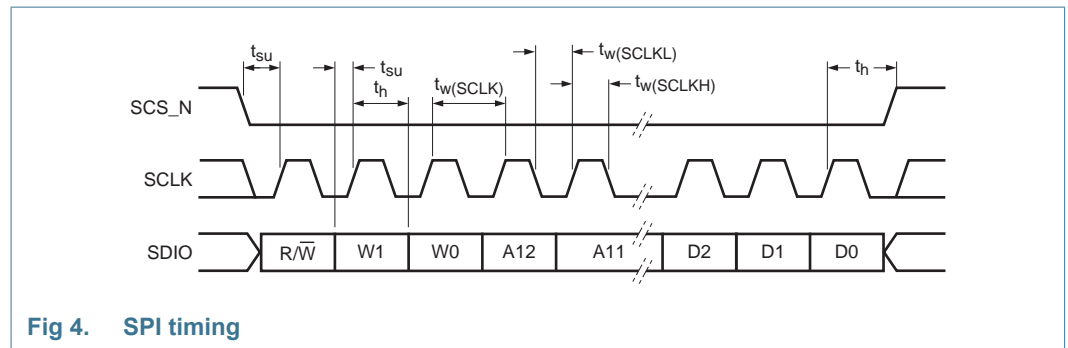

Fig 4. SPI timing

10.3 Typical dynamic performances<sup>1</sup>

10.3.1 Typical FFT at 122.88 Msps

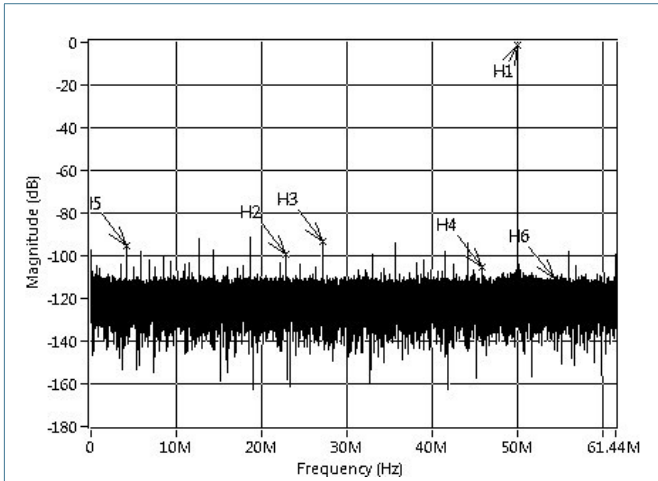

Fig 5. 1-tone FFT: -1 dBFS;  $f_i = 50$  MHz;  $f_s = 122.88$  Msps

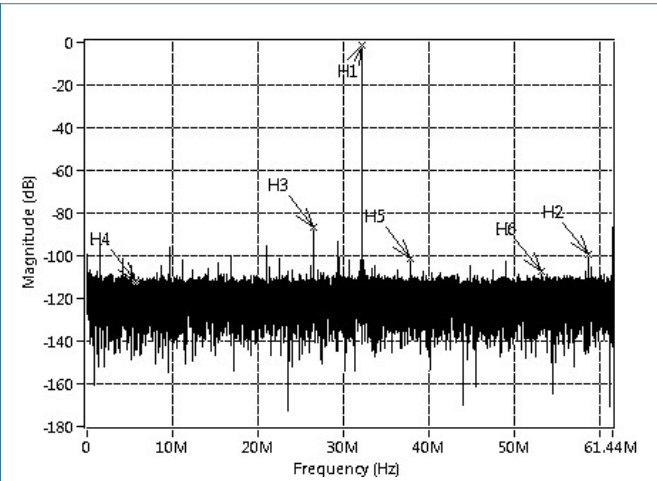

Fig 6. 1-tone FFT: -1 dBFS;  $f_i = 155$  MHz;  $f_s = 122.88$  Msps

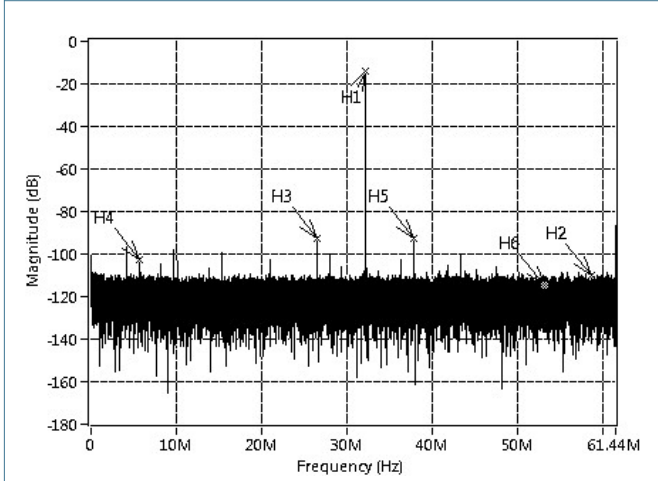

Fig 7. 1-tone FFT: -14 dBFS;  $f_i = 155$  MHz;  $f_s = 122.88$  Msps

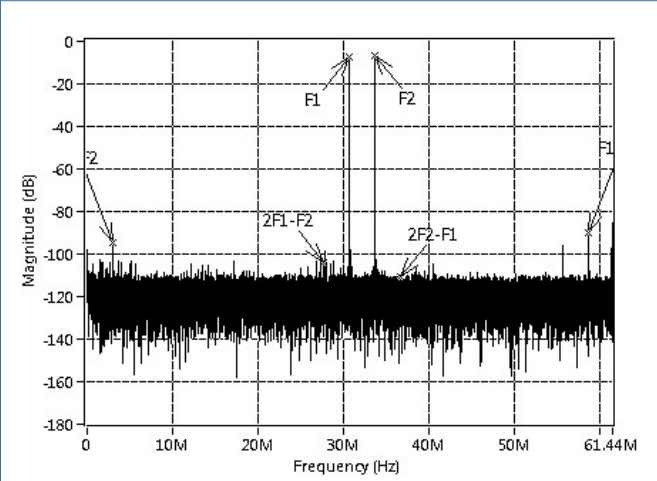

Fig 8. 2-tone FFT: -7 dBFS;  $f_{i1} = 153.5$  MHz;  $f_{i2} = 156.5$  MHz;  $f_s = 122.88$  Msps

1. Typical values measured at  $V_{DDA} = V_{DDO} = 1.8$  V;  $T_{amb} = 25$  °C

10.3.2 Typical FFT at 153.6 Mps

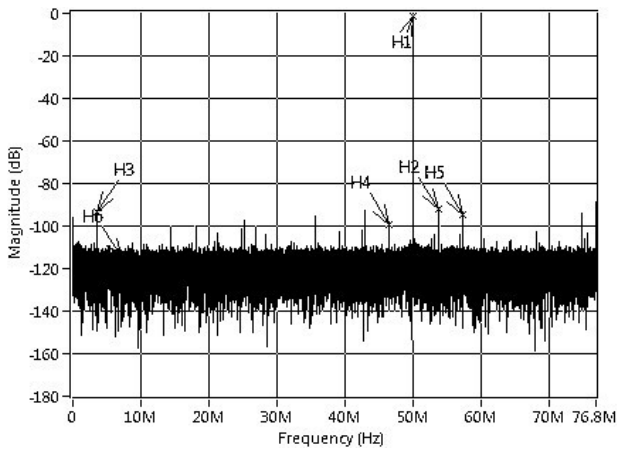

Fig 9. 1-tone FFT: -1 dBFS;  $f_i = 50$  MHz;  $f_s = 153.6$  Mps

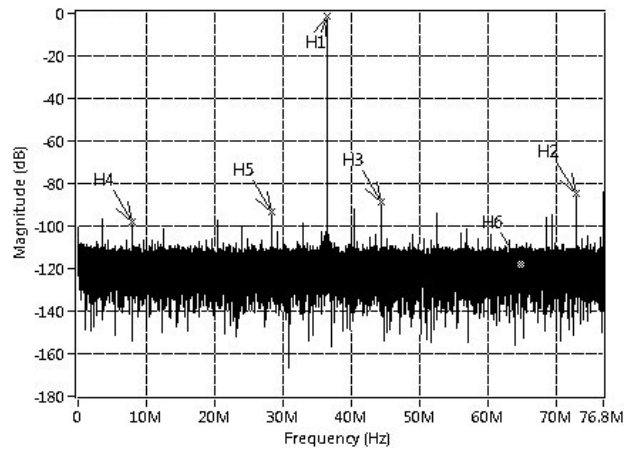

Fig 10. 1-tone FFT: -1 dBFS;  $f_i = 190$  MHz;  $f_s = 153.6$  Mps

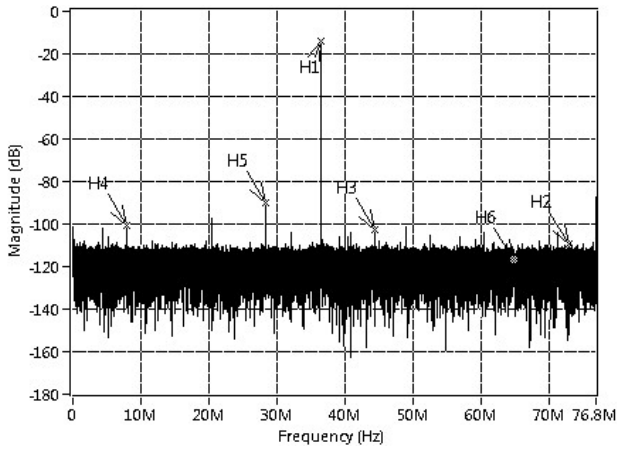

Fig 11. 1-tone FFT: -14 dBFS;  $f_i = 190$  MHz;  $f_s = 153.6$  Mps

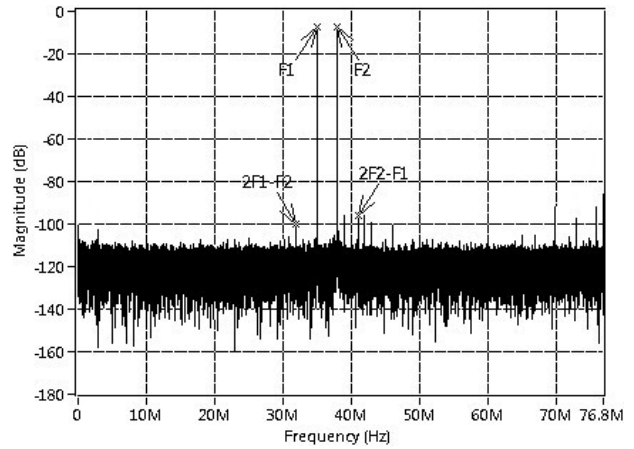

Fig 12. 2-tone FFT: -7 dBFS;  $f_{i1} = 188.5$  MHz;  $f_{i2} = 191.5$  MHz;  $f_s = 153.6$  Mps

10.3.3 Typical FFT at 184.32 Msps

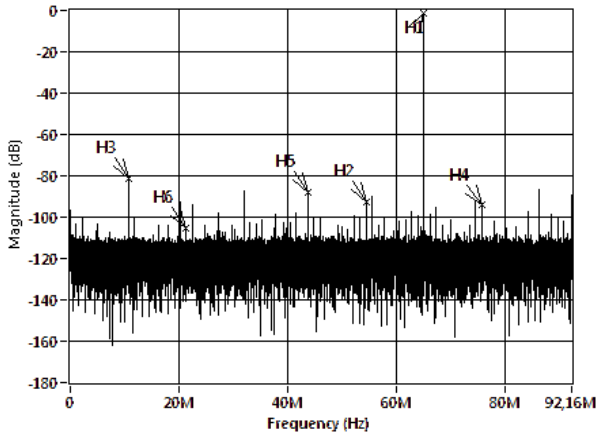

Fig 13. 1-tone FFT: -1 dBFS;  $f_i = 65$  MHz;  $f_s = 184.32$  Msps

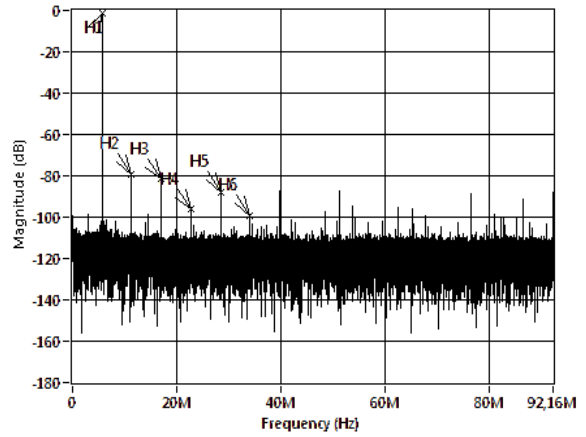

Fig 14. 1-tone FFT: -1 dBFS;  $f_i = 190$  MHz;  $f_s = 184.32$  Msps

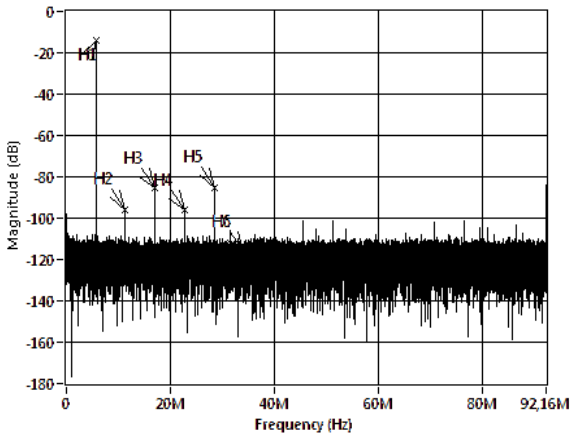

Fig 15. 1-tone FFT: -14 dBFS;  $f_i = 190$  MHz;  $f_s = 184.32$  Msps

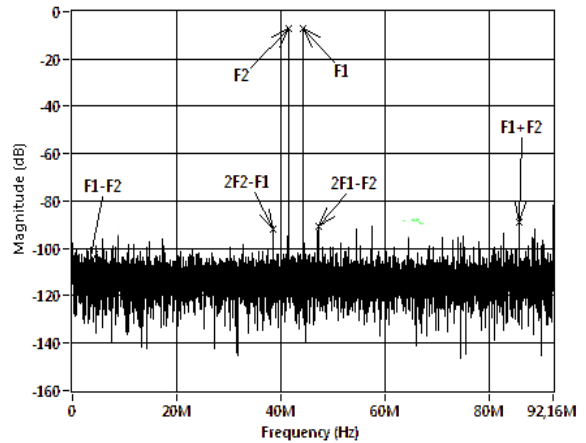

Fig 16. 2-tone FFT: -7 dBFS;  $f_{i1} = 140$  MHz;  $f_{i2} = 143$  MHz;  $f_s = 184.32$  Msps



10.3.4 Typical SNR performances

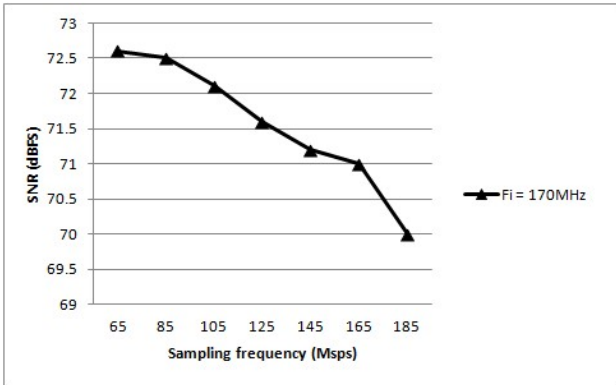

Fig 17. SNR as a function of sampling frequency: -1 dBFS;  $f_i = 170$  MHz

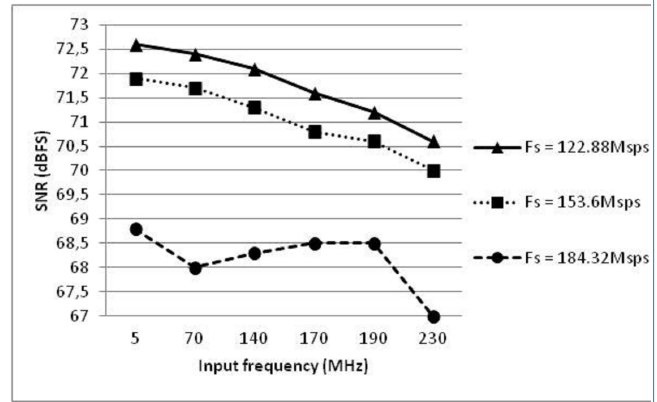

Fig 18. SNR as a function of input frequency: -1 dBFS

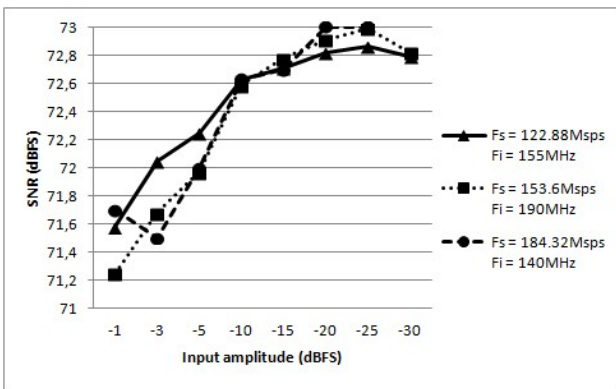

Fig 19. SNR as a function of input amplitude:  $V_{L(dif)} = 2$  V

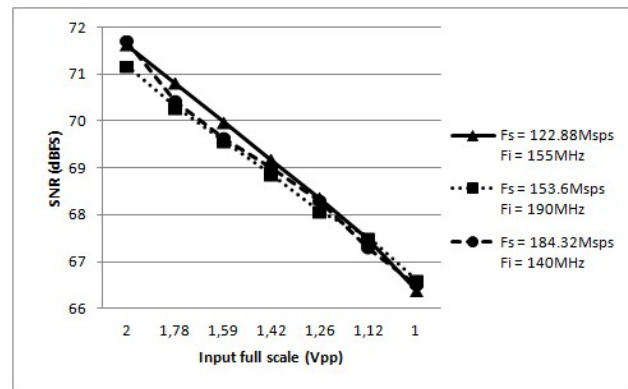

Fig 20. SNR as a function of full-scale amplitude: -1 dBFS

10.3.5 Typical SFDR performances

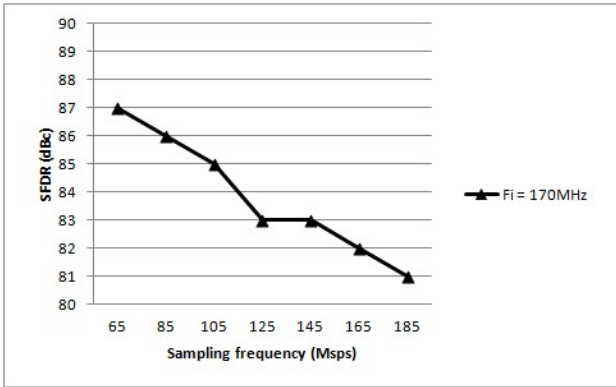

Fig 21. SFDR as a function of sampling frequency: -1 dBFS;  $f_i = 170$  MHz

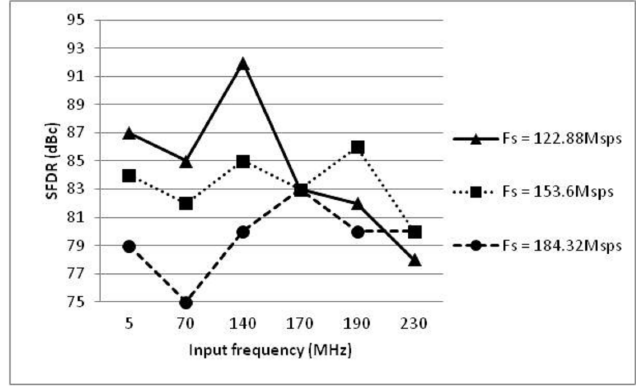

Fig 22. SFDR as a function of input frequency: -1 dBFS

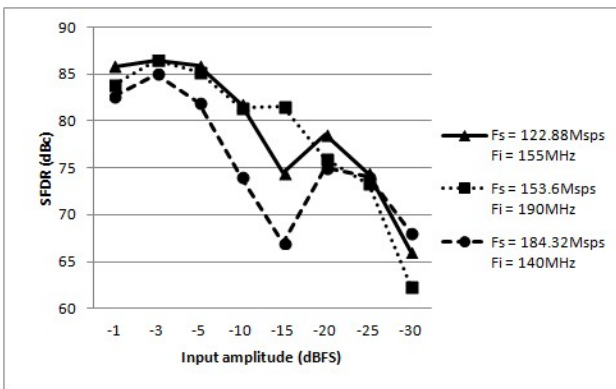

Fig 23. SFDR as a function of input amplitude:  $V_{I(dif)} = 2$  V

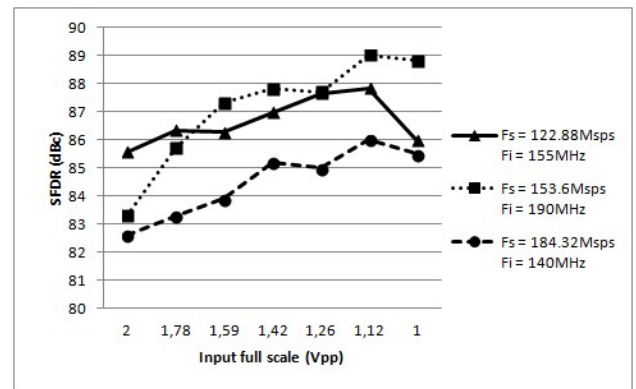

Fig 24. SFDR as a function of full-scale amplitude: -1 dBFS

10.3.6 Typical IMD3 performances

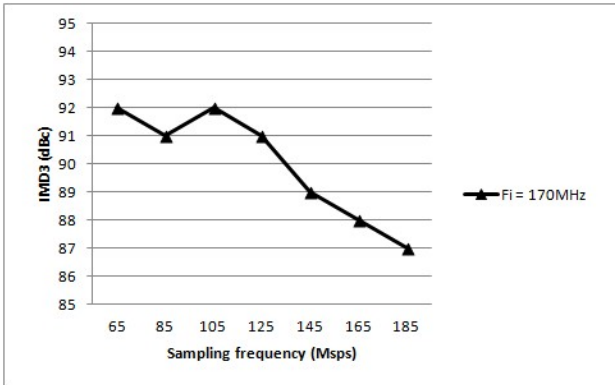

Fig 25. IMD3 as a function of sampling frequency: -7 dBFS;  $f_{i1} = 168.5$  MHz;  $f_{i2} = 171.5$  MHz

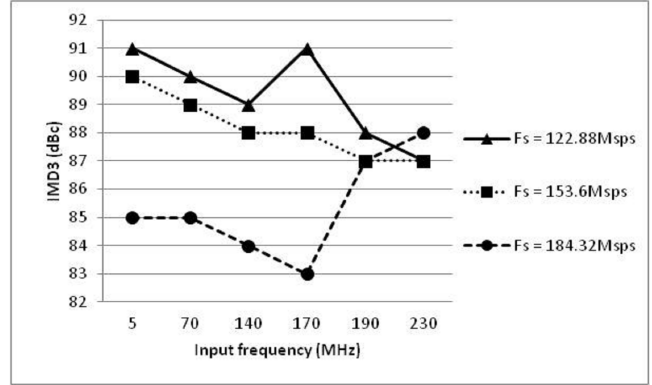

Fig 26. IMD3 as a function of input frequency: -7 dBFS; 3 MHz spacing

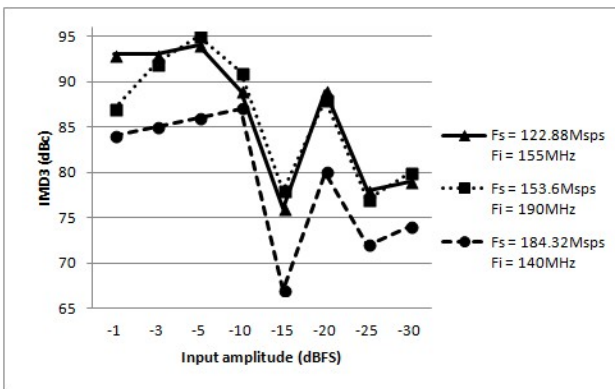

Fig 27. IMD3 as a function of input amplitude: 3 MHz spacing;  $V_{I(dif)} = 2$  V

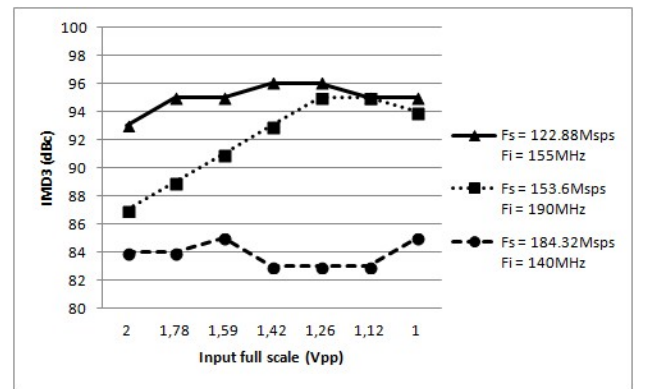

Fig 28. IMD3 as a function of full-scale amplitude: -7 dBFS; 3 MHz spacing

## 11. Application information

### 11.1 Analog inputs

#### 11.1.1 Input stage

The analog input of the ADC1443D supports a differential or a single-ended input drive. Optimal performance is achieved using differential inputs with respect to the common-mode input voltage ( $V_{I(cm)}$ ) on pins INP and INM.

The equivalent circuit of the sample and hold input stage, including ElectroStatic Discharge (ESD) protection circuit and package parasitics, is shown in [Figure 29](#).

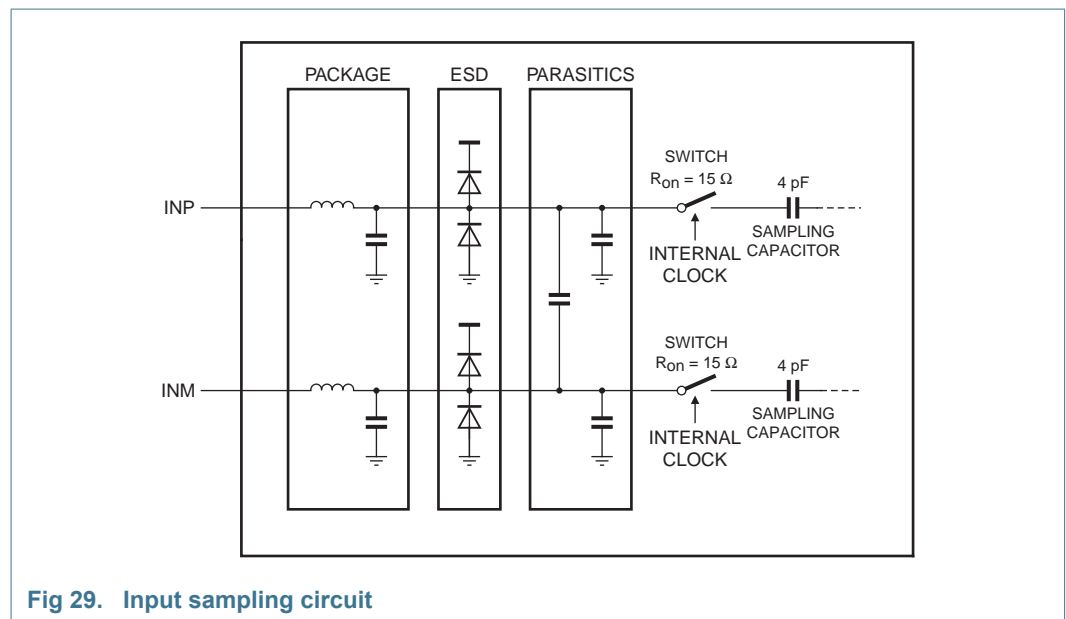

Fig 29. Input sampling circuit

The sample phase occurs when the internal sampling clock (derived from the clock signal on pin CLKP/CLKM) is HIGH. The voltage is then held on the sampling capacitors. When the sampling clock signal becomes LOW, the device enters the hold phase and the voltage information is transmitted to the ADC core.

#### 11.1.2 Common-mode input voltage ( $V_{I(cm)}$ )

Set the common-mode input voltage ( $V_{I(cm)}$ ) on pins INP and INM externally to 0.9 V for optimal performance.

#### 11.1.3 Pin VCM

When the input stage is AC-coupled, pin VCM can be used to set the common-mode reference for the analog inputs, for instance, via a transformer middle point. Connect a 0.1  $\mu$ F filter capacitor between pin VCM and ground to ensure a low-noise common-mode output voltage.

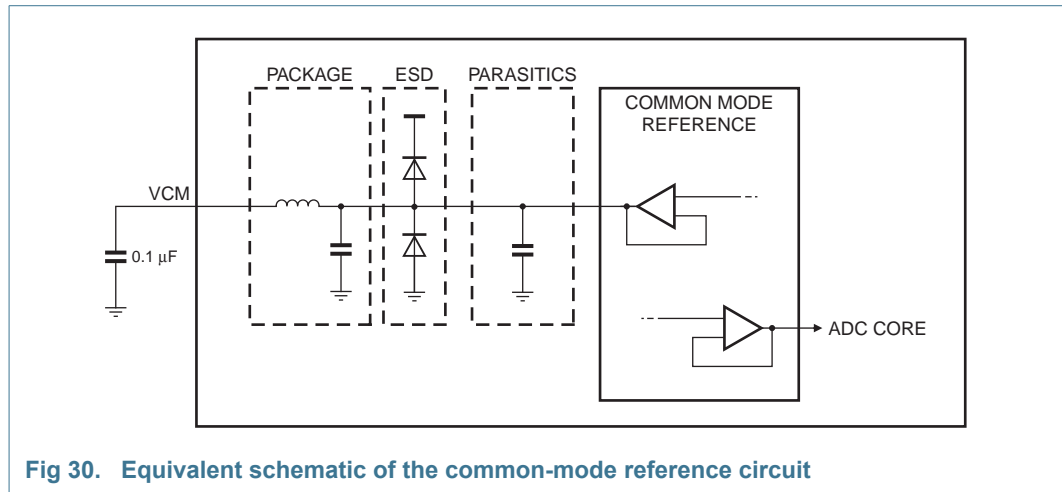

Fig 30. Equivalent schematic of the common-mode reference circuit

### 11.1.4 Programmable full-scale

The full-scale analog input voltage range is configurable between 1 V (p-p) and 2 V (p-p) by programming internal reference gain between 0 dB and -6 dB in 1 dB steps. The full-scale range can be set independently via bits INTREF[2:0] of the SPI local registers (see [Table 11](#) and [Table 30](#)).

Table 11. Reference gain control  
Default values are shown highlighted.

INTREF[2:0]	Level (dB)	Full-scale (V (p-p))
<b>000</b>	<b>0</b>	<b>2</b>
001	-1	1.78
010	-2	1.59
011	-3	1.42
100	-4	1.26
101	-5	1.12
110	-6	1
111	reserved	x

### 11.1.5 Anti-kickback circuitry

An anti-kickback circuitry (RC-filter in [Figure 31](#)) is required to counteract the effects of the charge injection generated by the sampling capacitance.

The RC-filter is also used to filter noise from the signal before it reaches the sampling stage. It is recommended that the capacitor has a value that maximizes noise attenuation without degrading the settling time excessively.

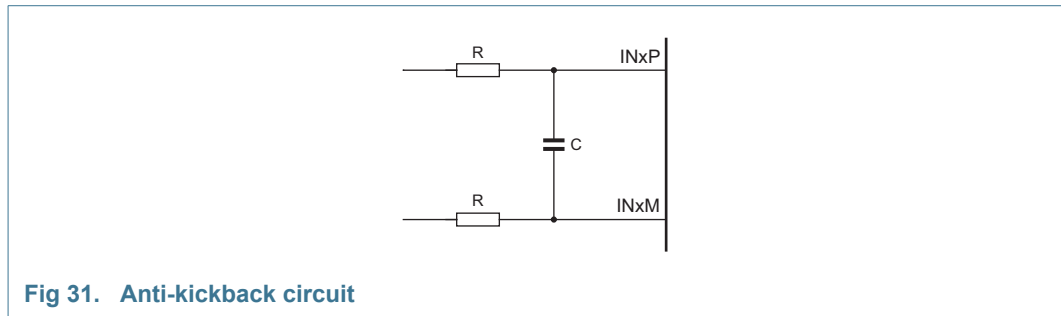

**Fig 31. Anti-kickback circuit**

The input frequency determines the component values. Select values that do not affect the input bandwidth. The values given in the following table are advised for 50Ω impedance system.

**Table 12. RC coupling versus input frequency; typical values**

Input frequency range (MHz)	R (Ω)	C (pF)
0 to 50	25	12
50 to 200	10	3.9
200 to 300	6.8	3

### 11.1.6 Transformer

The input frequency determines the configuration of the transformer circuit. The configuration shown in [Figure 32](#) is suitable for a baseband application.

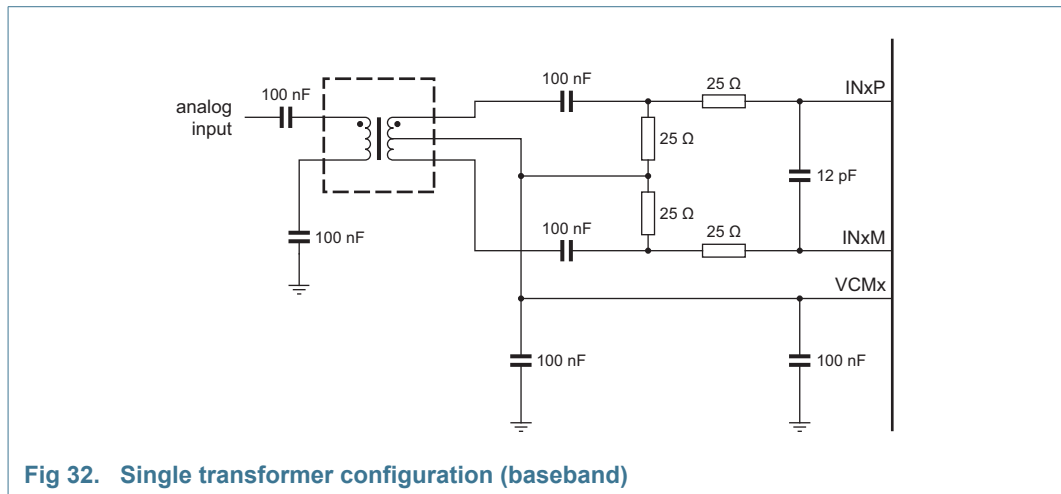

**Fig 32. Single transformer configuration (baseband)**

The configuration shown in [Figure 33](#) is recommended for high-frequency applications. In both cases, the choice of transformer is a compromise between cost and performance.

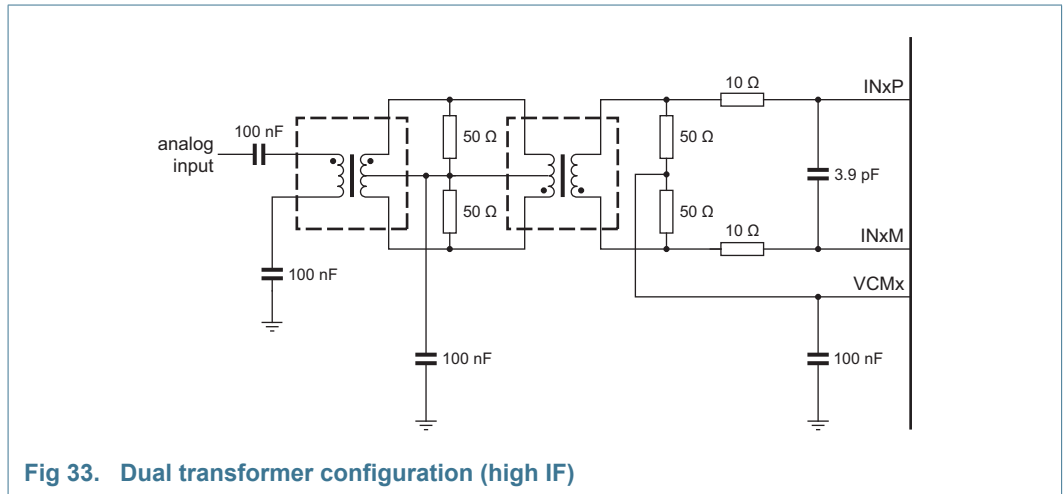

## 11.2 Clock input

### 11.2.1 Drive modes

The ADC1443D series can be driven differentially (LVPECL, LVDS or SINE). A single-ended LVCMOS signal connected to either pin CLKP or pin CLKM can also drive the device (connect the complementary pin to ground using a capacitor). The LVPECL is recommended for an optimal performance.

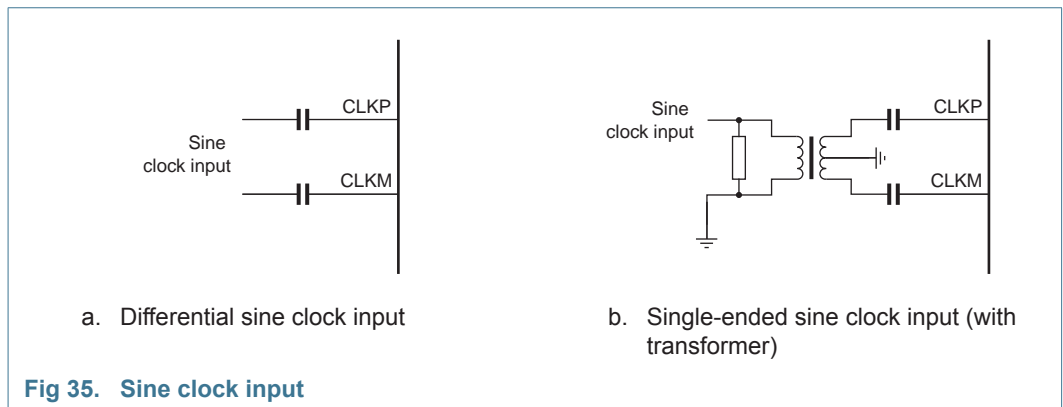
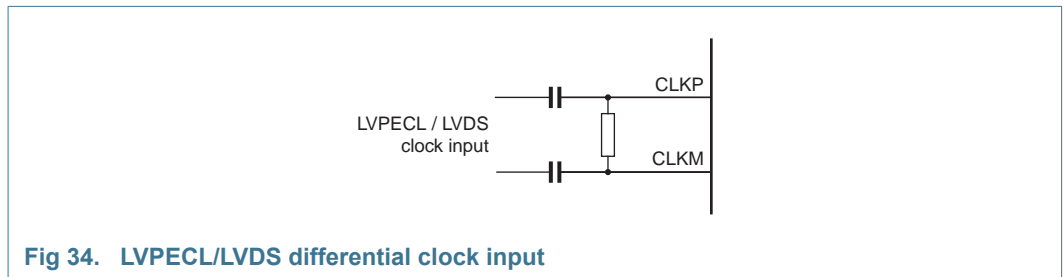

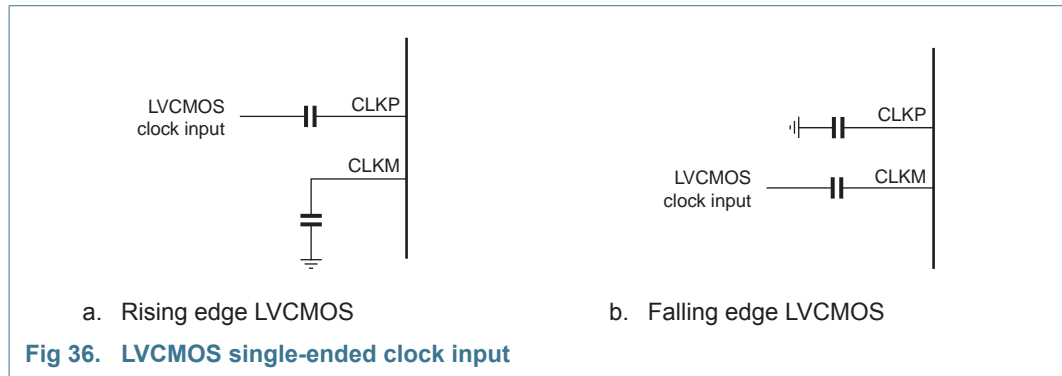

Single-ended or differential clock inputs can be selected via bit DIFF\_SE of SPI. If single-ended is enabled, the input pin (pin CLKM or pin CLKP) is selected using control bit SE\_SEL (see [Table 29](#)).

### 11.2.2 Equivalent input circuit

[Figure 37](#) shows the equivalent circuit of the input clock buffer. The input signal must be AC-coupled and the common-mode voltage of the differential input stage is set via internal 5 kΩ resistors.

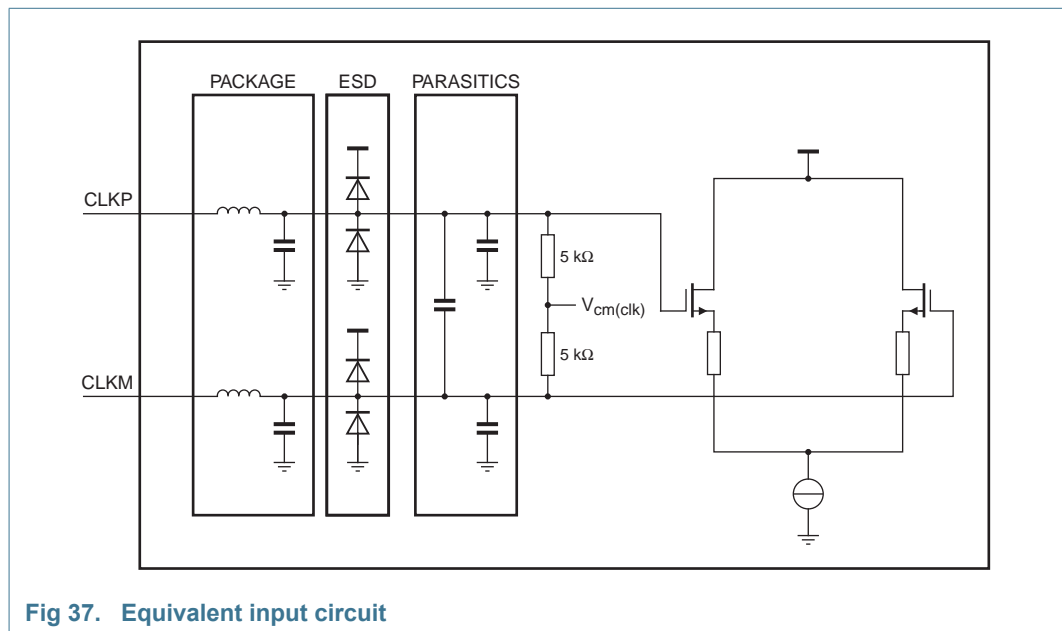

### 11.2.3 JESD204B harmonic clocking

The ADC1443D embeds an input clock divider that divides the incoming clock (clock frequency  $f_{clk}$ ) by a factor of 1 to 8. The output of this divider is then used as sampling clock (sampling frequency  $f_s$ ) (see bits CLK\_DIV[2:0] in [Table 29](#)). This feature allows a higher clock frequency to be delivered to the ADC1443D, which ultimately leads to better jitter performance and better SNR.

The ADC1443D should not be driven with a clock higher than 250 Msps if the clock divider is not enabled, otherwise there is a risk of metastability.



Caution must be taken to first, power the ADC1443 in « Power Down» mode by setting the CFG Pins to «1111» see [Table 18](#) , second, program the clock divider to the wanted value (see bits CLK\_DIV[1:0] in [Table 29](#)) and finally, set the ADC using the SPI register IP\_CFG\_SETUP [Table 42](#), to the wanted configuration.

#### 11.2.4 JESD204B Deterministic Latency (pins SYSREFN and SYSREFP or SYNCBP and SYNCBN)

In the JESD204B standard 3 subclasses have been defined.

**Subclass 0:** No deterministic latency is required (equivalent to the JESD204A)

**Subclass 1:** Deterministic latency is required and is realized through the dedicated SYSREFP/N pins.

The deterministic latency can be controlled with a single-ended or a differential SYSREF signal.

When SYSREF is active (High by default), it resets the clock divider phase registers. In a multi-device application and when the clock divider factor is higher than 1, all sampling clock edges for multiple ADC1443D will be aligned (see [Table 8](#) and [Figure 3](#)).

On top of this, the SYSREFP/N pins initiates an internal LMFC clock ( Local Multi-frame Clock), with a frequency of a multi-frame ( $F_s/K$ ) ( K: number of frames per multi-frame) see table [Table 18](#) for examples.

At a SYNC request from the receiver (on pins SYNCBP/N), K28.5 comma characters are sent over the serial lanes. When the receiver releases the SYNC request, then the Initial Lane Alignment (ILA) will start at an edge of the LMFC

At the receiver side, the different lanes are aligned using the ILA start of frame ch and fetched at the next LMFC boundary.

This operation ensures a deterministic latency. see the JESD204B JEDEC standard for more information.

**Subclass2 :** Behaviour is similar to Subclass1, but, instead of using a dedicated SYSREF signal, the SYNCBP/N is used for both SYNC request and deterministic latency.

The rising edge of the SYNCBP/N start the LMFC, while the falling edge set the SYNC request and hence start the Initial Lane Alignment according to the JEDEC JESD204B standard.

Below is an example of a Subclass1 ADC1443D registers programming :

**Table 13. Subclass1 path activation**

Register	value	Comment
DCS_CTRL (@0x043)	0xC7	Choose the SYSREFP/N on rising edge as DCS Reset
JESD204B_CTRL1 (@810)	0xC0	Enable an LMFC periodic reset
JESD204B_CTRL2 (@811)	0x40	Enable a one shot DCS reset
JESD204B_CTRL3 (@812)	0x0A	Activate a Sync fetch at LMFC boundary
SYSREF_CFG (@81E)	0x08	Enable SYSREFP/N on differential mode

11.3 Digital outputs

11.3.1 Digital output buffers

The JESD204A/JESD204B standard specifies that both the receiver and the transmitter must share the same supply if they are connected in DC-coupling.

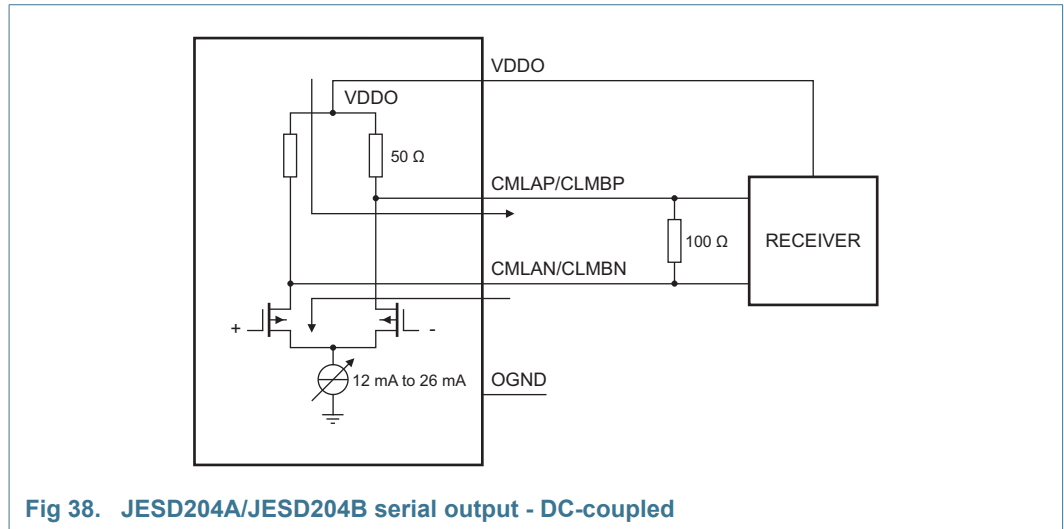

Fig 38. JESD204A/JESD204B serial output - DC-coupled

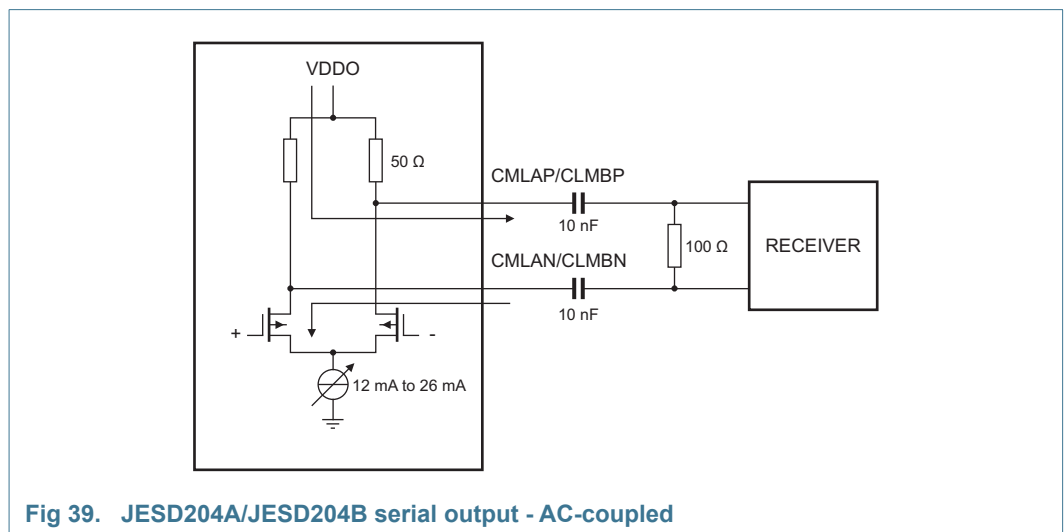

Fig 39. JESD204A/JESD204B serial output - AC-coupled

11.3.2 JESD204A/JESD204B serializer

11.3.2.1 Digital JESD204A/JESD204B formatter

The block placed after the ADC1443D cores implements all the JESD204A/JESD204B standard functionalities. This ensures signal integrity and guarantees the clock and the data recovery at the receiver side.

The block is highly configurable in various ways depending on the sampling frequency and the number of lanes used. All the processing and transmission are done with MSB first.

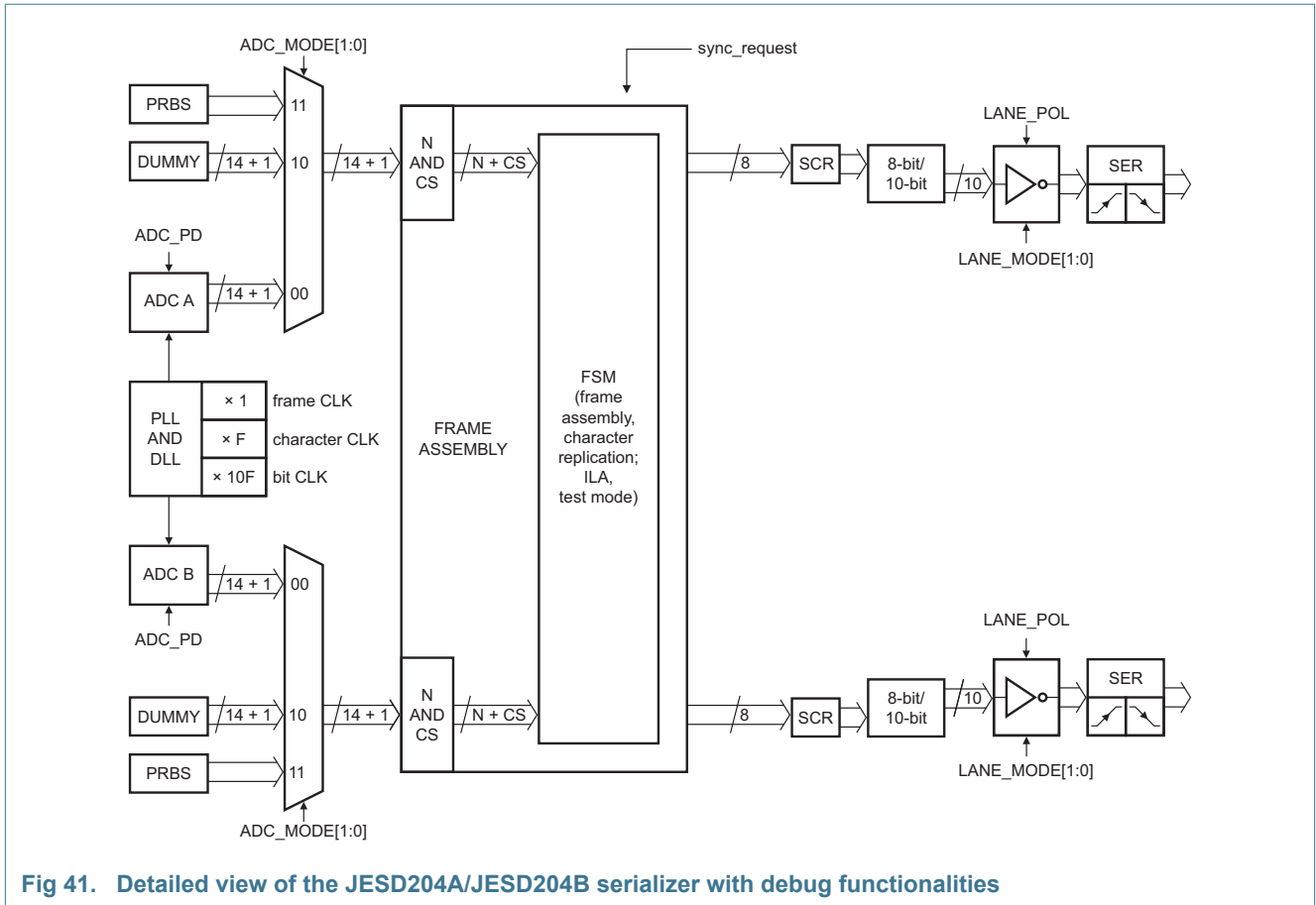
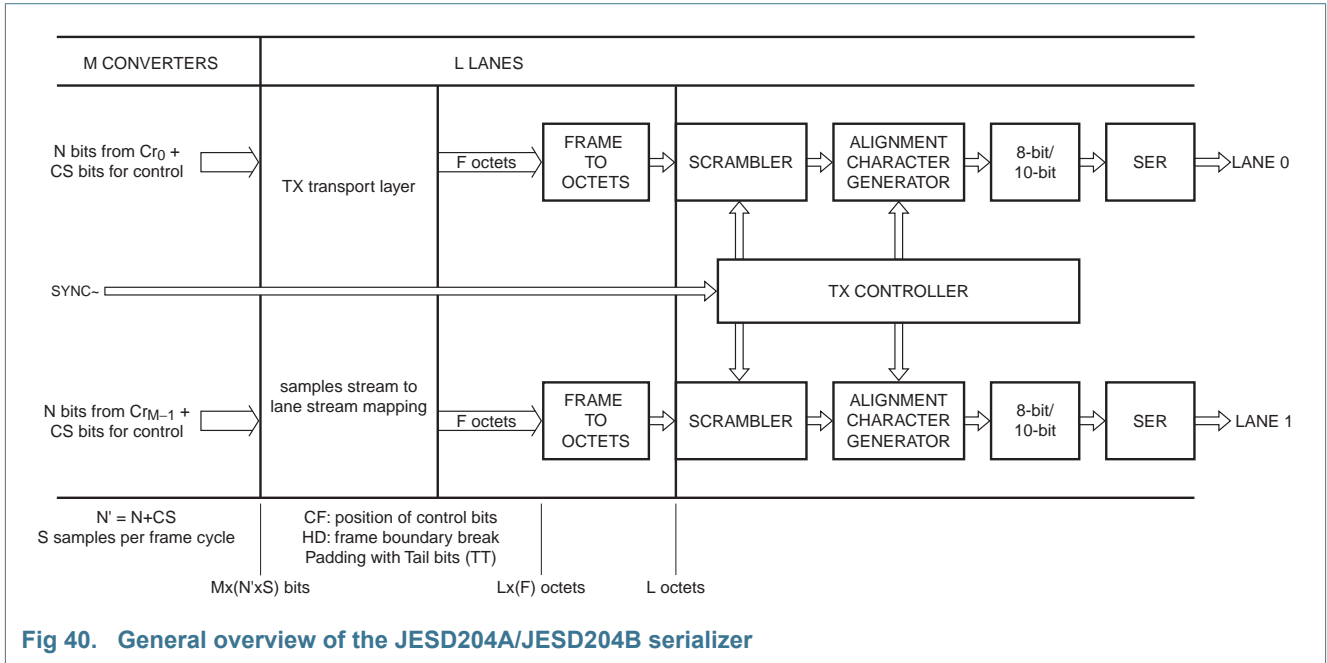

### 11.3.2.2 Scrambler (SCR\_EN)

The main purpose of scrambling is to avoid the spectral peaks that would be produced when the same data octet repeats from frame to frame. In general, scrambling makes the spectrum data-independent, so that possible frequency-selective effects on the electrical interface will not cause data-dependent errors. However, all digital operations in converters (including scrambling) cause some amount of switching noise, so there may be applications where it is of advantage to disable the scrambling.

The scrambler can be selected via the pin SCR\_EN or the SPI registers (bit SCR\_EN in [Table 57](#)).

**Table 14. Scrambler configuration**

Pin SCR_EN	Scrambler
HIGH	enabled
LOW	disabled

An internal pull-up resistor (50 k $\Omega$ ) sets pin SCR\_EN to HIGH when no signal is connected to it. The pin SCR\_EN is active only at start-up or after a JESD204B reset (bit SCR\_EN in [Table 41](#)).

### 11.3.3 OuT-of-Range (OTR)

An out-of-range signal is provided on pins OTRA and OTRB. The OTR signal goes logic level HIGH when the input signal exceeds the maximum full scale range.

The latency of OTR is 31 clock cycles. The OTR response can be speeded up by enabling fast OTR using SPI local registers (bit FAST\_OTR in [Table 37](#)). In this mode, the latency of OTR is reduced to only 11 clock cycles. The fast OTR detection threshold (below full-scale) can be programmed using the SPI local registers (bits FAST\_OTR\_DET[2:0] in [Table 37](#)).

**Table 15. Fast OTR register threshold**

FAST_OTR_DET[2:0]	Detection level (dB)
000	-18.06
001	-14.54
010	-12.04
011	-8.52
<b>100</b>	<b>-6.02</b>
101	-4.08
110	-2.5
111	-1.16

### 11.3.4 Digital offset

By default, the ADC1443D delivers an output code that corresponds to the analog input. However, it is possible to add a digital offset to the output code using the SPI local registers (bits DIG\_OFFSET[5:0] in see [Table 16](#) and [Table 33](#)). The digital offset adjustment is coded in two's complement.

**Table 16. Digital offset adjustment***Default values are shown highlighted.*

DIG_OFFSET[5:0]	Digital offset adjustment (LSB)
10 0000	-32
10 0001	-31
...	...
11 1111	-1
<b>00 0000</b>	<b>0</b>
00 0001	+1
...	...
01 1110	+30
01 1111	+31

### 11.3.5 Test patterns

The ADC1443D can be configured to transmit a number of predefined test patterns using the SPI local registers (bits TEST\_PAT\_SEL[2:0] in [Table 17](#) and [Table 34](#)). The selected test pattern is transmitted regardless of the analog input.

**Table 17. Digital test pattern selection***Default values are shown highlighted.*

TEST_PAT_SEL[2:0]	Digital test pattern
<b>000</b>	<b>Off</b>
001	Mid code
010	Min code
011	Max code
100	Toggle '1111..1111'/'0000..0000'
101	Custom test pattern
110	'0101..0101'
111	'1010..1010'

A custom test pattern can be defined using the SPI local registers (bits TEST\_PAT\_USER[13:6] in [Table 35](#) and bits TEST\_PAT\_USER[5:0] in [Table 36](#)).

### 11.3.6 Output data format selection

The ADC1443D output data format can be selected (offset binary, two's complement or gray code) using the SPI local registers (bits DATA\_FORMAT[1:0] in [Table 32](#)).

### 11.3.7 Output codes versus input voltage

**Table 18. Output codes**

$V_{INP} - V_{INM}$	Offset binary	Two's complement	Gray code	OTR
< -1	00 0000 0000 0000	10 0000 0000 0000	00 0000 0000 0000	1
-1	00 0000 0000 0000	10 0000 0000 0000	00 0000 0000 0000	0
-0.99987793	00 0000 0000 0001	10 0000 0000 0001	00 0000 0000 0001	0
-0.99975586	00 0000 0000 0010	00 0000 0000 0010	00 0000 0000 0011	0
...	...	...	...	0
-0.00024414	01 1111 1111 1110	11 1111 1111 1110	01 0000 0000 0001	0

Table 18. Output codes ...continued

$V_{INP} - V_{INM}$	Offset binary	Two's complement	Gray code	OTR
-0.00012207	01 1111 1111 1111	11 1111 1111 1111	01 0000 0000 0000	0
+0.00012207	10 0000 0000 0000	00 0000 0000 0000	11 0000 0000 0000	0
+0.0.00024414	10 0000 0000 0001	00 0000 0000 0001	11 0000 0000 0001	0
...	...	...	...	0
+0.99975586	11 1111 1111 1101	01 1111 1111 1101	10 0000 0000 0011	0
+0.99987793	11 1111 1111 1110	01 1111 1111 1110	10 0000 0000 0001	0
+1	11 1111 1111 1111	01 1111 1111 1111	10 0000 0000 0000	0
> +1	11 1111 1111 1111	01 1111 1111 1111	10 0000 0000 0000	1

### 11.4 Configuration pins (CFG0, CFG1, CFG2, CFG3)

The configuration pins are only active as inputs at start-up. The values on those pins are read once to set up the device. Then the pins become outputs (OTRA and OTRB). Any further modification must be applied via SPI registers.

Each of these pins is internally connected to a 50 k $\Omega$  pull-down resistor. In case of harmonic sampling, it is recommended to connect externally a 1 k $\Omega$  pull-up resistor in order to start in power-down mode.

Table 19. JESD204B configuration table

CFG 3	CFG 2	CFG 1	CFG 0	ADC A	ADC B	Lane A	Lane B	F <sup>[1]</sup>	HD <sup>[1]</sup>	K <sup>[1]</sup>	M <sup>[1]</sup>	L <sup>[1]</sup>
0	0	0	0	ON	ON	ON	ON	2	0	9	2	2
0	0	0	1	ON	ON	ON	OFF	4	0	5	2	1
0	0	1	0	ON	ON	OFF	ON	4	0	5	2	1
0	0	1	1				reserved					
0	1	0	0				reserved					
0	1	0	1	ON	OFF	ON	OFF	2	0	9	1	1
0	1	1	0	ON	OFF	OFF	ON	2	0	9	1	1
0	1	1	1	OFF	ON	ON	OFF	2	0	9	1	1
1	0	0	0	OFF	ON	OFF	ON	2	0	9	1	1
1	0	0	1	ON	OFF	ON	ON	1	1	17	1	2
1	0	1	0	OFF	ON	ON	ON	1	1	17	1	2
1	0	1	1				reserved					
1	1	0	0				reserved					
1	1	0	1				reserved					
1	1	1	0				reserved					
1	1	1	1	OFF	OFF	OFF	OFF	2	0	9	2	2

- [1] F: Octets per frame clock cycle  
 HD: High-density mode  
 K: Frame per multi-frame  
 M: Converters per device  
 L: Lane per converter device

For all the configurations, the number of control bit per conversion sample (CS) is 1, the number of control words per frame clock cycle and link (CF) is 0, the number of samples transmitter per single converter per frame cycle (S) is 1 and the formula  $(F \times K) \geq 17$  is always verified.

## 11.5 Serial Peripheral Interface (SPI)

### 11.5.1 Register description

The ADC1443D serial interface is a synchronous serial communication port, which allows easy interfacing with many commonly used microprocessors. It provides access to the registers controlling the operation of the chip.

The register bits are either global or local functions:

- A global function operates over the full IC behavior. A local function operates on one or several previously selected channels only. If a channel is selected, the next WRITE command in the local registers applies to the selected channel. The WRITE command has no impact on channels that are not selected. This makes it possible to apply different configurations on each channel by first selecting a specific channel and then all the related settings.
- Select only one channel during a READ operation of the local registers. If several channels are selected, the READ operation occurs on the channel A.

Programming all registers at the same time is required:

- The IC allows the storage of a set of settings for the addresses 06h to 23h, which enables the configuration of all registers simultaneously by setting bit TRANSFER to HIGH (see [Table 39](#)). This bit is autoclearing. This function can be disabled using SPI (bit TRANS\_DIS in [Table 39](#)). The registers are then updated at each WRITE operation.
- The transfer function does not apply to a READ operation.

The SPI interface is configured as a 3-wire type: pin SDIO is the bidirectional pin, pin SCLK is the serial clock input and SCS\_N is the chip select pin.

A LOW level on pin SCS\_N initiates each READ/WRITE operation. A minimum of 3 bytes is transmitted (two instruction bytes and at least 1 DATA byte; see [Table 21](#)).

**Table 20. Instruction bytes for the SPI**

Bit:	7 (MSB)	6	5	4	3	2	1	0 (LSB)
Description	R/ $\overline{W}$	W1	W0	A12	A11	A10	A9	A8
	A7	A6	A5	A4	A3	A2	A1	A0

- Bit R/ $\overline{W}$  indicates whether it is a READ (when HIGH) or a WRITE (when LOW) operation.
- Bits W1 and W0 indicate the number of bytes to be transferred after both instruction bytes (see [Table 21](#)).

**Table 21. Number of data bytes transferred**

W1	W0	Number of bytes transferred
0	0	1 byte
0	1	2 bytes
1	0	3 bytes
1	1	4 or more bytes



- Bits A12 to A0 indicate the address of the register being accessed. If it concerns a multiple byte transfer, this address is the first register accessed. An address counter is increased to access subsequent addresses.

The steps for a data transfer are:

1. Communication starts with the first rising edge on pin SCLK after a falling edge on pin SCS\_N.
2. The first phase is the transfer of the 2-byte instruction.
3. The second phase is the transfer of the data. Its length varies, but it is always a multiple of 8 bits. The MSB is always sent first (for instruction and data bytes).
4. A rising edge on pin SCS\_N indicates the end on data transmission.

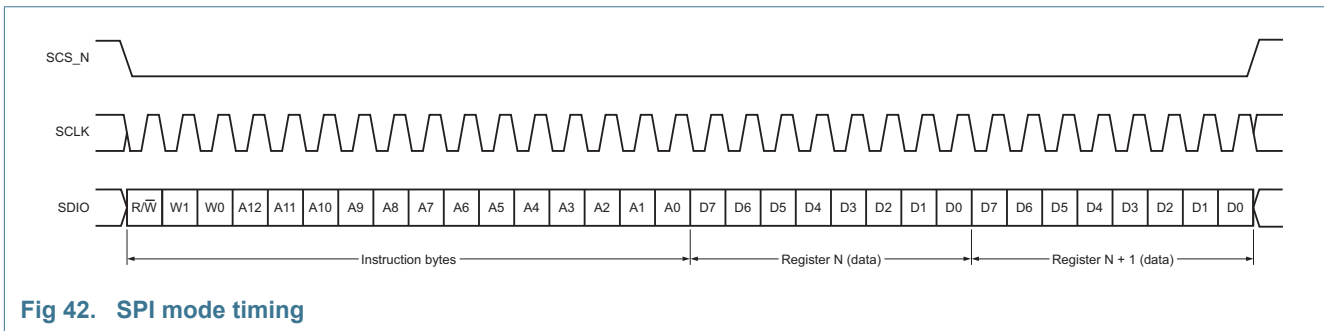

Fig 42. SPI mode timing

### 11.5.2 Start-up programming

At power-up or after a reset by SPI, the device needs a start-up programming for optimum performances. This initialization is done in 3 steps:

**Table 22. Step 1 - Clock divider programming**

register address (hex)	value (hex)	comment
0007	CLK_DIV[2:0] in <a href="#">Table 29</a>	in case of harmonic clocking

**Table 23. Step 2 - JESD204B initialization**

register address (hex)	value (hex)	comment
0803	CFG_SETUP[3:0] in <a href="#">Table 42</a>	JESD204B configuration
0802	08	frame assembler subclock reset

**Table 24. Step 3 - ADC core initialization**

register address (hex)	ADC1443D125 value (hex)	ADC1443D160 value (hex)	ADC1443D200 value (hex)	comment
0100	d1	d1	d1	
0200	01	01	01	
00ff	80	80	80	registers updated on each WRITE command
0102	07	07	07	
0103	63	65	66	
0012	10	10	10	
0108	a7	a3	a3	
010a	c0	c0	c0	
0154	01	01	01	
0155	-	-	03	
0156	10	-	d8	
0160	-	-	ff	
0161	17	07	17	
0170	-	-	10	
0171	-	-	10	
0400	b0	b0	30	
-	-	-	-	wait for 400 ms
0004	08	08	08	
-	-	-	-	wait for 400 ms
0004	10	10	10	
-	-	-	-	wait for 400 ms
0004	20	20	20	

Those registers adjust some specific currents and timings. The programmed values should not be modified by the customer to ensure proper behavior over temperature and power supply variations.

### 11.5.3 Register allocation map

Table 25 shows an overview of all registers.

Table 25. Register allocation map

Addr. (hex)	Register name	R/W	Bit definition							Default		
			Bit 7	Bit 6	Bit 5	Bit 4	Bit 3	Bit 2	Bit 1		Bit 0	
<b>ADC control registers</b>												
0000h	CHIP_RST	RW	SW_RST[7:0]							0000 0000		
0001h	CHIP_ID	R	CHIP_ID[7:0] <sup>[1]</sup>							0100 0011		
0005h	SW_RST	R/W	SW_RST	-	-	-	-	-	-	-	0000 0000	
0006h	OP_MODE <sup>[2]</sup>	R/W	-	-	-	-	-	-	OP_MODE[1:0] <sup>[3]</sup>		0000 0000	
0007h	CLK_CFG	R/W	-	-	-	SE_SEL	DIFF_SE	CLK_DIV[2:0]		0000 0000		
0008h	INTERNAL_REF	R/W	-	-	-	-	-	INTREF[2:0]		0000 0000		
0009h	CHANNEL_SEL	R/W	-	-	-	-	-	-	ADC_B	ADC_A	0000 1111	
0011h	OUTPUT_CFG	R/W	-	-	-	-	-	DATA_SWAP	DATA_FORMAT[1:0]		0000 0000	
0013h	DIG_OFFSET	R/W	DIG_OFFSET[5:0]							-	-	0000 0000
0014h	TEST_CFG_1	R/W	-	-	-	-	-	TEST_PAT_SEL[2:0]		0000 0000		
0015h	TEST_CFG_2	R/W	TEST_PAT_USER[13:6]							0000 0000		
0016h	TEST_CFG_3	R/W	TEST_PAT_USER[5:0]							-	-	0000 0000
0017h	OTR_CFG	R/W	-	-	-	RESERVED	FAST_OTR	FAST_OTR_DET[2:0]		0001 0100		
0043h	DCS_CTRL	R/W	RESERVED[5:0]							DIV_RESET_POL	DIV_RESET_SEL	11000100
00FFh	TRANS_CFG	R/W	TRANS_DIS	TRANSFER	-	-	-	-	-	-	0000 0000	
<b>JESD204A/JESD204B control</b>												
0801h	IP_STATUS	R	RXSYNC_ERR_FLG	RESERVED[5:0]							PLL_LOCK	0100 0010
0802h	IP_RST	R/W	SW_RST	-	-	-	ASSEMBLER_SW_RST	-	-	-	0000 0000	
0803h	IP_CFG_SETUP	R/W	-	-	-	-	CFG_STP[3:0]				0000 0000	

Table 25. Register allocation map ...continued

Addr. (hex)	Register name	R/W	Bit definition							Default	
			Bit 7	Bit 6	Bit 5	Bit 4	Bit 3	Bit 2	Bit 1		Bit 0
0805h	IP_CTRL1	R/W	RESERVED	TRISTATE_CFG_PAD	SYNCB_POL	SYNCB_SE	EN_RXSYNC_ERR	RESERVED[2:0]			0000 1001
0806h	IP_CTRL2	R/W	RESERVED[5:0]					SWP_LANE_1_2	SWP_ADC_0_1	0011 0100	
080Bh	IP_PRBS_CTRL	R/W	RESERVED[5:0]					PRBS_TYPE	RES	0000 0000	
0810h	JESD204B_CTRL1	R/W	LMFC_periodic_rst	LMFC_reset_en	-	-	-	-	-	0000 0000	
0811h	JESD204B_CTRL2	R/W	DCS_periodic_rst	DCS_reset_en	-	-	-	-	-	0000 0000	
0812h	JESD204B_CTRL3	R/W	-	-	-	-	sync_at_lmfc_en	-	sync_capture_path	0000 0000	
0816h	IP_DEBUG_OUT1	R/W	-	-	-	-	-	-	PAT_OUT[9:8]	0000 0010	
0817h	IP_DEBUG_OUT2	R/W	PAT_OUT[7:0]							1010 1010	
0818h	IP_DEBUG_IN1	R/W	PAT_IN[15:8]							1110 0110	
0819h	IP_DEBUG_IN2	R/W	PAT_IN[7:0]							1110 1010	
081Bh	IP_TESTMODE	R/W	RESERVED	LOOP_ALIGN	DIS_REPL_CHAR	BYP_ALIGN	RESERVED[3:0]			0000 0000	
081Ch	IP_EXPERT_DOOR	R/W	KEY[7:0]							0000 0000	
081Eh	SYSREF_CFG	R/W	-	-	-	-	SYSREF_EN	SYSREF_SE	-	0000 0000	
0822h	SCR_L	R/W	SCR_EN	RESERVED[5:0]					L	0000 0001	
0824h	CFG_K	R/W	-	-	-	K[4:0]			000x xxxx		
086Bh	OUTBUF_A_SWING	R/W	RESERVED[4:0]				SWING[2:0]			0000 0010	
086Ch	OUTBUF_B_SWING	R/W	RESERVED[4:0]				SWING[2:0]			0000 0010	

Table 25. Register allocation map ...continued

Addr. (hex)	Register name	R/W	Bit definition							Default
			Bit 7	Bit 6	Bit 5	Bit 4	Bit 3	Bit 2	Bit 1	
0871h	LANE_A_0_ CTRL	R/W	RESERVED[2:0]			LANE_MODE[1:0]	LANE_POL	RESERVED	LANE_ PD	0000 0000
0872h	LANE_B_0_ CTRL	R/W	RESERVED[2:0]			LANE_MODE[1:0]	LANE_POL	RESERVED	LANE_ PD	0000 0000
0890h	ADC_A_0_ CTRL	R/W	-	-	ADC_MODE[1:0]	-	-	-	ADC_ PD	0000 0000
0891h	ADC_B_0_ CTRL	R/W	-	-	ADC_MODE[1:0]	-	-	-	ADC_ PD	0000 0000

[1] The READ-ONLY and RESERVED registers.

[2] The registers influenced by the TRANSFER function.

[3] The LOCAL registers.

### 11.5.4 Detailed register description

The tables in this section contain detailed descriptions of the registers.

#### 11.5.4.1 ADC control registers

**Table 26. CHIP\_RESET register (address 0000h) bit description**

Default settings are shown highlighted.

Bit	Symbol	Access	Value	Description
7 to 0	SW_RST	R/W	-	resets global and local registers for any value “1” written at any bit (autoclear).

**Table 27. SW\_RESET register (address 0005h) bit description**

Default settings are shown highlighted.

Bit	Symbol	Access	Value	Description
7	SW_RST	R/W	0	resets global and local registers <b>no reset</b>
			1	performs a reset to the default values (autoclear)
6 to 0	-	-	-	not used

**Table 28. OP\_MODE register (address 0006h) bit description**

Default settings are shown highlighted.

Bit	Symbol	Access	Value	Description
7 to 2	-	-	-	not used
1 to 0	OP_MODE[1:0] <sup>[1]</sup>	R/W	00	operating mode for the selected channel <b>normal (power-up)</b>
			01	power-down
			10	sleep
			11	not used

[1] Local register.

**Table 29. CLK\_CFG register (address 0007h) bit description**

Default settings are shown highlighted.

Bit	Symbol	Access	Value	Description
7 to 5	-	-	-	not used
4	SE_SEL	R/W	0	single-ended clock input pin selection <b>CLKP</b>
			1	CLKM
3	DIFF_SE	R/W	0	differential/single-ended clock input selection <b>fully differential</b>
			1	single-ended

**Table 29. CLK\_CFG register (address 0007h) bit description ...continued**

Default settings are shown highlighted.

Bit	Symbol	Access	Value	Description
2 to 0	CLK_DIV[2:0]	R/W		clock divider selection
			<b>000</b>	<b>divide by 1</b>
			001	divide by 2
			010	divide by 3
			011	divide by 4
			100	divide by 5
			101	divide by 6
			110	divide by 7
			111	divide by 8

**Table 30. INTERNAL\_REF register (address 0008h) bit description**

Default settings are shown highlighted.

Bit	Symbol	Access	Value	Description
7 to 3	-	-	-	not used
2 to 0	INTREF[2:0] <sup>[1]</sup>	R/W	<b>000</b>	see <a href="#">Table 11</a>

[1] Local register

**Table 31. CHANNEL\_SEL register (address 0009h) bit description**

Default settings are shown highlighted.

Bit	Symbol	Access	Value	Description
7 to 2	-	-	-	not used
1	ADC_B	R/W		channel B selection for next SPI operation in local registers
			0	not selected
			<b>1</b>	<b>selected</b>
0	ADC_A	R/W		channel A selection for next SPI operation in local registers
			0	not selected
			<b>1</b>	<b>selected</b>

**Table 32. OUTPUT\_CFG register (address 0011h) bit description**

Default settings are shown highlighted.

Bit	Symbol	Access	Value	Description
7 to 3	-	-	-	not used
2	DATA_SWAP <sup>[1]</sup>	R/W		output data bits swapped
			<b>0</b>	<b>no swapping</b>
			1	MSBs swapped with LSBs

**Table 32. OUTPUT\_CFG register (address 0011h) bit description ...continued**

Default settings are shown highlighted.

Bit	Symbol	Access	Value	Description
1 to 0	DATA_FORMAT[1:0] <sup>[1]</sup>	R/W		output data format
			<b>00</b>	<b>offset binary</b>
			01	two's complement
			10	gray code
			11	offset binary

[1] Local register

**Table 33. DIG\_OFFSET register (address 0013h) bit description**

Default settings are shown highlighted.

Bit	Symbol	Access	Value	Description
7 to 2	DIG_OFFSET[7:0] <sup>[1]</sup>	R/W	<b>000000</b>	see <a href="#">Table 16</a>
1 to 0	-	-	-	not used

[1] Local register

**Table 34. TEST\_CFG\_1 register (address 0014h) bit description**

Default settings are shown highlighted.

Bit	Symbol	Access	Value	Description
7 to 3	-	-	-	not used
2 to 0	TEST_PAT_SEL[2:0] <sup>[1]</sup>	R/W	<b>000</b>	see <a href="#">Table 17</a>

[1] Local register

**Table 35. TEST\_CFG\_2 register (address 0015h) bit description**

Default settings are shown highlighted.

Bit	Symbol	Access	Value	Description
7 to 0	TEST_PAT_USER[13:6] <sup>[1]</sup>	R/W	<b>00000000</b>	custom digital test pattern (bits 13 to 6)

[1] Local register

**Table 36. TEST\_CFG\_3 register (address 0016h) bit description**

Default settings are shown highlighted.

Bit	Symbol	Access	Value	Description
7 to 2	TEST_PAT_USER[5:0] <sup>[1]</sup>	R/W	<b>000000</b>	custom digital test pattern (bits 5 to 0)
1 to 0	-	-	-	not used

[1] Local register

**Table 37. OTR\_CFG register (address 0017h) bit description**

Default settings are shown highlighted.

Bit	Symbol	Access	Value	Description
7 to 5	-	-	-	not used
4	RESERVED	R/W	1	reserved



**Table 37. OTR\_CFG register (address 0017h) bit description ...continued**

Default settings are shown highlighted.

Bit	Symbol	Access	Value	Description
3	FAST_OTR <sup>[1]</sup>	R/W		Selection OTR full-scale/ fast OTR
			<b>0</b>	<b>OTR full-scale</b>
			1	fast OTR
2 to 0	FAST_OTR_DET[2:0] <sup>[1]</sup>	R/W	<b>100</b>	see <a href="#">Table 15</a>

[1] Local register

**Table 38. DCS\_CTRL register (address 0043h) bit description**

Default settings are shown highlighted.

Bit	Symbol	Access	Value	Description
7 to 2	RESERVED	R/W	110001	reserved
1	DIV_RESET_POL	R/W		Polarity of the DCS reset
			<b>0</b>	<b>falling edge (Subclass 2)</b>
			1	Rising edge (Subclass 1)
0	DIV_RESET_SEL	R/W		DCS reset selection
			<b>0</b>	<b>SYNCBP/N is used (Subclass 2)</b>
			1	SYSREFP/N is used (Subclass 1)

**Table 39. TRANS\_CFG register (address 00FFh) bit description**

Default settings are shown highlighted.

Bit	Symbol	Access	Value	Description
7	TRANS_DIS	R/W		disable transfer function
			<b>0</b>	<b>transfer function active</b>
			1	registers updated on a WRITE command
6	TRANSFER	R/W		updates the registers with the written settings
			<b>0</b>	<b>settings are stored</b>
			1	registers updated (autoclear)
5 to 0	-	-	-	not used

## 11.5.4.2 JESD204A/JESD204B control registers

Table 40. IP\_STATUS register (address 0801h) bit description

Default settings are shown highlighted.

Bit	Symbol	Access	Value	Description
7	RXSYNC_ERR_FLG	R	<b>0</b> 1	RX synchronization error <b>no error</b> synchronization error has occurred
6 to 1	RESERVED	R/W	100001	reserved
0	PLL_LOCK	R	<b>0</b> 1	JEDEC PLL lock <b>unlocked</b> locked

Table 41. IP\_RESET register (address 0802h) bit description

Default settings are shown highlighted.

Bit	Symbol	Access	Value	Description
7	SW_RST	R/W	<b>0</b> 1	resets All JESD204B sub-blocks and registers <b>no reset</b> performs a reset to the default values (auto-clear)
6 to 4	-	-	-	not used
3	ASSEMBLER_SW_RST	R/W	<b>0</b> 1	resets RXSYNC_ERR_FLG register bit and the frame assembler sub-block <b>no reset</b> performs a reset to the default values (auto-clear)
2 to 0	-	-	-	not used

Table 42. IP\_CFG\_SETUP register (address 0803h) bit description

Default settings are shown highlighted.

Bit	Symbol	Access	Value	Description
7 to 4	-	-	-	not used
3 to 0	CFG_SETUP[3:0]	R/W	<b>0000</b>	see <a href="#">Table 43</a>

Table 43. JESD204B configuration table

CFG_SETUP [3:0]	ADC A	ADC B	Lane A	Lane B	F <sup>[1]</sup>	HD <sup>[1]</sup>	K <sup>[1]</sup>	M <sup>[1]</sup>	L <sup>[1]</sup>	Lane A serial frequency	Lane B serial frequency
0000	<b>ON</b>	<b>ON</b>	<b>ON</b>	<b>ON</b>	2	0	9	2	2	20 × f <sub>s</sub>	20 × f <sub>s</sub>
0001	<b>ON</b>	<b>ON</b>	<b>ON</b>	OFF	4	0	5	2	1	40 × f <sub>s</sub>	0
0010	<b>ON</b>	<b>ON</b>	OFF	<b>ON</b>	4	0	5	2	1	0	40 × f <sub>s</sub>
0011										reserved	
0100										reserved	
0101	<b>ON</b>	OFF	<b>ON</b>	OFF	2	0	9	1	1	20 × f <sub>s</sub>	0
0110	<b>ON</b>	OFF	OFF	<b>ON</b>	2	0	9	1	1	0	20 × f <sub>s</sub>
0111	OFF	<b>ON</b>	<b>ON</b>	OFF	2	0	9	1	1	20 × f <sub>s</sub>	0
1000	OFF	<b>ON</b>	OFF	<b>ON</b>	2	0	9	1	1	0	20 × f <sub>s</sub>
1001	<b>ON</b>	OFF	<b>ON</b>	<b>ON</b>	1	1	17	1	2	10 × f <sub>s</sub>	10 × f <sub>s</sub>

Table 43. JESD204B configuration table ...continued

CFG_SETUP [3:0]	ADC A	ADC B	Lane A	Lane B	F <sup>[1]</sup>	HD <sup>[1]</sup>	K <sup>[1]</sup>	M <sup>[1]</sup>	L <sup>[1]</sup>	Lane A serial frequency	Lane B serial frequency
1010	OFF	ON	ON	ON	1	1	17	1	2	$10 \times f_s$	$10 \times f_s$
1011										reserved	
1100										reserved	
1101										reserved	
1110										reserved	
1111	OFF	OFF	OFF	OFF	2	0	9	2	2	0	0

[1] F: Octets per frame clock cycle

HD: High-density mode

K: Frame per multi-frame

M: Converters per device

L: Lane per converter device

For all the configurations, the number of control bit per conversion sample (CS) is 1, the number of control words per frame clock cycle and link (CF) is 0, the number of samples transmitter per single converter per frame cycle (S) is 1 and the formula  $(F \times K) \geq 17$  is always verified.

Table 44. IP\_CTRL1 register (address 0805h) bit description

Default settings are shown highlighted.

Bit	Symbol	Access	Value	Description
7	RESERVED	R/W	0	reserved
6	TRISTATE_CFG_PAD	R/W	0	CFG pad in tri-state mode
			1	CFG Pads in Output mode
			1	CFG Pads in Input mode; operating at power-up
5	SYNCB_POL	R/W	0	selects synchronization polarity
			1	synchronization active HIGH
			0	<b>synchronization active LOW</b>
4	SYNCB_SE	R/W	0	selects single-ended or differential synchronization
			1	single-ended synchronization on SYNCBP
			0	<b>differential synchronization</b>
3	EN_RXSYNC_ERR	R/W	0	selects single-ended or differential synchronization
			1	differential synchronization
			1	<b>single-ended synchronization on SYNCBP</b>
2 to 0	RESERVED	R/W	001	reserved

Table 45. IP\_CTRL2 register (address 0806h) bit description

Default settings are shown highlighted.

Bit	Symbol	Access	Value	Description
7 to 2	RESERVED	R/W	001101	reserved
1	SWP_LANE_A_B	R/W	0	swaps the lanes
			1	no swap
			1	lane A and B are inverted

**Table 45. IP\_CTRL2 register (address 0806h) bit description ...continued**

Default settings are shown highlighted.

Bit	Symbol	Access	Value	Description
0	SWP_ADC_A_B	R/W		swaps the ADC at the input of the frame assembler
			0	<b>no swap</b>
			1	ADC A and B are inverted

**Table 46. IP\_PRBS\_CTRL register (address 080Bh) bit description**

Default settings are shown highlighted.

Bit	Symbol	Access	Value	Description
7 to 2	RESERVED	R/W	000000	reserved
1	PRBS_TYPE	R/W		Pseudo-Random Binary Sequence (PRBS) pattern selection
			0	<b>PRBS-7; <math>1 + x^6 + x^7</math></b>
			1	PRBS-23; $1 + x^{18} + x^{23}$
0	RESERVED	R/W	0	reserved

**Table 47. JESD204B\_CTRL1 register (address 0810h) bit description**

Default settings are shown highlighted.

Bit	Symbol	Access	Value	Description
7	LMFC_periodic_rst	R/W		LMFC mode definition
			0	<b>LMFC reset is done once</b>
			1	LMFC reset at each SYSREF or SYNC pulse
6	LMFC_reset_en	R/W		LMFC reset selection
			0	<b>SYNCBP/N is used (Subclass 2)</b>
			1	SYSREFP/N is used (Subclass 1)
5 to 0	RESERVED	R/W	00000	reserved

**Table 48. JESD204B\_CTRL2 register (address 0811h) bit description**

Default settings are shown highlighted.

Bit	Symbol	Access	Value	Description
7	DCS_periodic_rst	R/W		DCS mode definition
			0	<b>DCS reset is done once</b>
			1	DCS reset at each SYSREF or SYNC pulse
6	DCS_reset_en	R/W		DCS reset selection
			0	<b>DCS reset is disabled</b>
			1	DCS reset is enabled
5 to 0	RESERVED	R/W	00000	reserved

**Table 49. JESD204B\_CTRL3 register (address 0812h) bit description**

Default settings are shown highlighted.

Bit	Symbol	Access	Value	Description
7 to 4	RESERVED	R/W	0000	reserved
3	sync_at_lmfc_en	R/W	0	defines the relation between SYNC and LMFC <b>SYNC is fetched directly (Subclass 0)</b>
			1	SYNC is taken at next LMFC boundary (Subclass 1 and Subclass 2)
2	RESERVED	R/W	0	reserved
1	sync_capture_path	R/W	0	selects SYNC mode <b>Subclass 0</b>
			1	Subclass 1 and Subclass 2
0	RESERVED	R/W	0	reserved

**Table 50. IP\_DEBUG\_OUT1 register (address 0816h) bit description**

Default settings are shown highlighted.

Bit	Symbol	Access	Value	Description
7 to 2	-	-	-	not used
1 to 0	PATTERN_OUT[9:8]	R/W	<b>10</b>	2 most significant bits of output stage debug word (inserted just before serializer)

**Table 51. IP\_DEBUG\_OUT2 register (address 0817h) bit description**

Default settings are shown highlighted.

Bit	Symbol	Access	Value	Description
7 to 0	PATTERN_OUT[7:0]	R/W	<b>1010 1010</b>	8 least significant bits of output stage debug word (inserted just before serializer)

**Table 52. IP\_DEBUG\_IN1 register (address 0818h) bit description**

Default settings are shown highlighted.

Bit	Symbol	Access	Value	Description
7 to 0	PATTERN_IN[15:8]	R/W	<b>1110 0110</b>	8 most significant bits of input stage debug word (inserted in place of ADC data)

**Table 53. IP\_DEBUG\_IN2 register (address 0819h) bit description**

Default settings are shown highlighted.

Bit	Symbol	Access	Value	Description
7 to 0	PATTERN_IN[7:0]	R/W	<b>1110 1010</b>	8 least significant bits of input stage debug word (inserted in place of ADC data)

**Table 54. IP\_TESTMODE register (address 081Bh) bit description**

Default settings are shown highlighted.

Bit	Symbol	Access	Value	Description
7	RESERVED	R/W	0	reserved
6	LOOP_ALIGN	R/W	0	continuous ILA <sup>[1]</sup> sequence <b>normal operation</b>
			1	ILA <sup>[1]</sup> repeated continuously

**Table 54. IP\_TESTMODE register (address 081Bh) bit description ...continued**

Default settings are shown highlighted.

Bit	Symbol	Access	Value	Description
5	DIS_REPL_CHAR	R/W		character replacement function selection
			0	<b>normal operation</b>
			1	character replacement disabled
4	BYP_ALIGN	R/W		ILA <sup>[1]</sup> sequence function selection
			0	<b>normal operation</b>
			1	ILA <sup>[1]</sup> sequence disabled
3 to 0	RESERVED	R/W	0000	reserved

[1] ILA = Initial Lane Alignment Sequence (see JESD204 JEDEC standard).

**Table 55. IP\_EXPERT\_DOOR register (address 081Ch) bit description**

Default settings are shown highlighted.

Bit	Symbol	Access	Value	Description
7	KEY[7:0]	R/W	<b>0000 0000</b>	8-bit key (0x4a) to enable write access for scrambler (register 0828h)

**Table 56. SYSREF\_CFG register (address 081Eh) bit description**

Default settings are shown highlighted.

Bit	Symbol	Access	Value	Description
7 to 4	RESERVED	R/W	0000	reserved
3	SYSREF_EN	R/W		enables SYSREFP/N path
			0	<b>SYSREFP/N path disabled</b>
			1	SYSREFP/N path enabled
2	SYSREF_SE	R/W		selects single-ended or differential SYSREF
			0	<b>SYSREFP/SYREFN are used as differential pair</b>
			1	SYSREFP is used as single ended SYSREF input
1 to 0	RESERVED	R/W	00	reserved

**Table 57. SCR\_L register (address 0822h) bit description (IP\_EXPERT\_DOOR write access needed)**

Default settings are shown highlighted.

Bit	Symbol	Access	Value	Description
7	SCR_EN	R/W		selects the scrambler function
			0	<b>scrambler disabled</b>
			1	scrambler enabled
6 to 1	RESERVED	R/W	000000	reserved
0	L	R/W		lanes number minus 1
			0	1 lane
			1	<b>2 lanes</b>

**Table 58. CFG\_K register (address 0824h) bit description (IP\_EXPERT\_DOOR write access needed, address 081Ch)**

Default settings are shown highlighted.

Bit	Symbol	Access	Value	Description
7 to 5	-	-	-	not used
4 to 0	K[4:0]	R/W	<b>000x xxxx</b>	Number of frames in a multi-frame. Default value depends on the JESD204B configuration.

**Table 59. IP\_OUTBUF00\_SWING register (address 086Bh) bit description**

Default settings are shown highlighted.

Bit	Symbol	Access	Value	Description
7 to 3	RESERVED[4:0]	R/W	00000	reserved
2 to 0	SWING[2:0]	R/W		Configurable lane 0 output current
			000	12 mA; $\pm 300$ mV (p-p)
			001	14 mA; $\pm 350$ mV (p-p)
			<b>010</b>	<b>16 mA; <math>\pm 400</math> mV (p-p)</b>
			011	18 mA; $\pm 450$ mV (p-p)
			100	20 mA; $\pm 500$ mV (p-p)
			101	22 mA; $\pm 550$ mV (p-p)
			110	24 mA; $\pm 600$ mV (p-p)
			111	26 mA; $\pm 650$ mV (p-p)

**Table 60. IP\_OUTBUF01\_SWING register (address 086Ch) bit description**

Default settings are shown highlighted.

Bit	Symbol	Access	Value	Description
7 to 3	RESERVED[4:0]	R/W	00000	reserved
2 to 0	SWING[2:0]	R/W		Configurable lane 1 output current
			000	12 mA; $\pm 300$ mV (p-p)
			001	14 mA; $\pm 350$ mV (p-p)
			<b>010</b>	<b>16 mA; <math>\pm 400</math> mV (p-p)</b>
			011	18 mA; $\pm 450$ mV (p-p)
			100	20 mA; $\pm 500$ mV (p-p)
			101	22 mA; $\pm 550$ mV (p-p)
			110	24 mA; $\pm 600$ mV (p-p)
			111	26 mA; $\pm 650$ mV (p-p)

**Table 61. IP\_LANE\_A\_0\_CTRL register (address 0871h) bit description**

Default settings are shown highlighted.

Bit	Symbol	Access	Value	Description
7 to 5	RESERVED[2:0]	R/W	000	reserved
4 to 3	LANE_MODE[1:0]	R/W		debug option directly before serializer
			<b>00</b>	<b>normal mode, ADC path</b>
			01	0/1 toggle sent over the lanes
			10	IP_DEBUG_OUT value sent over the lanes
			11	10-bit PRBS pattern is sent over the lane

Table 61. IP\_LANE\_A\_0\_CTRL register (address 0871h) bit description ...continued

Default settings are shown highlighted.

Bit	Symbol	Access	Value	Description
2	LANE_POL	R/W		selects lane polarity
			0	<b>no inversion</b>
			1	lane polarity P/N inverted
1	RESERVED	R/W	0	reserved
0	LANE_PD	R/W		Selects lane power mode
			0	<b>lane is powered-up</b>
			1	lane is powered-down

Table 62. IP\_LANE\_B\_0\_CTRL register (address 0872h) bit description

Default settings are shown highlighted.

Bit	Symbol	Access	Value	Description
7 to 5	RESERVED[2:0]	R/W	000	reserved
4 to 3	LANE_MODE[1:0]	R/W		debug option directly before serializer
			00	<b>normal mode, ADC path</b>
			01	0/1 toggle sent over the lanes
			10	IP_DEBUG_OUT value sent over the lanes
			11	10-bit PRBS pattern is sent over the lane
2	LANE_POL	R/W		selects lane polarity
			0	<b>no inversion</b>
			1	lane polarity P/N inverted
1	RESERVED	R/W	0	reserved
0	LANE_PD	R/W		Selects lane power mode
			0	<b>lane is powered-up</b>
			1	lane is powered-down

Table 63. IP\_ADC\_A\_0\_CTRL register (address 0890h) bit description

Default settings are shown highlighted.

Bit	Symbol	Access	Value	Description
7 to 6	RESERVED	R/W	00	reserved
5 to 4	ADC_MODE[1:0]	R/W		debug option at ADC output
			00	<b>normal mode, ADC path</b>
			01	normal mode, ADC path
			10	IP_DEBUG_IN value sent i.s.o. ADC data
			11	16-bit PRBS pattern is sent i.s.o. ADC data
3 to 1	RESERVED	R/W	000	reserved
0	ADC_PD	R/W		selects ADC power mode
			0	<b>ADC is powered-up</b>
			1	ADC is powered-down



Table 64. IP\_ADC\_B\_0\_CTRL register (address 0891h) bit description

Default settings are shown highlighted.

Bit	Symbol	Access	Value	Description
7 to 6	RESERVED	R/W	00	reserved
5 to 4	ADC_MODE[1:0]	R/W		debug option at ADC output
			<b>00</b>	<b>normal mode, ADC path</b>
			01	normal mode, ADC path
			10	IP_DEBUG_IN value sent i.s.o. ADC data
			11	16-bit PRBS pattern is sent i.s.o. ADC data
3 to 1	RESERVED	R/W	000	reserved
0	ADC_PD	R/W		selects ADC power mode
			<b>0</b>	<b>ADC is powered-up</b>
			1	ADC is powered-down

12. Package outline

VFQFPN56 : plastic thermal enhanced low profile quad flat package; no leads; 56 terminals; resin based; body 8 x 8 x 1.35 mm

PSC-4449

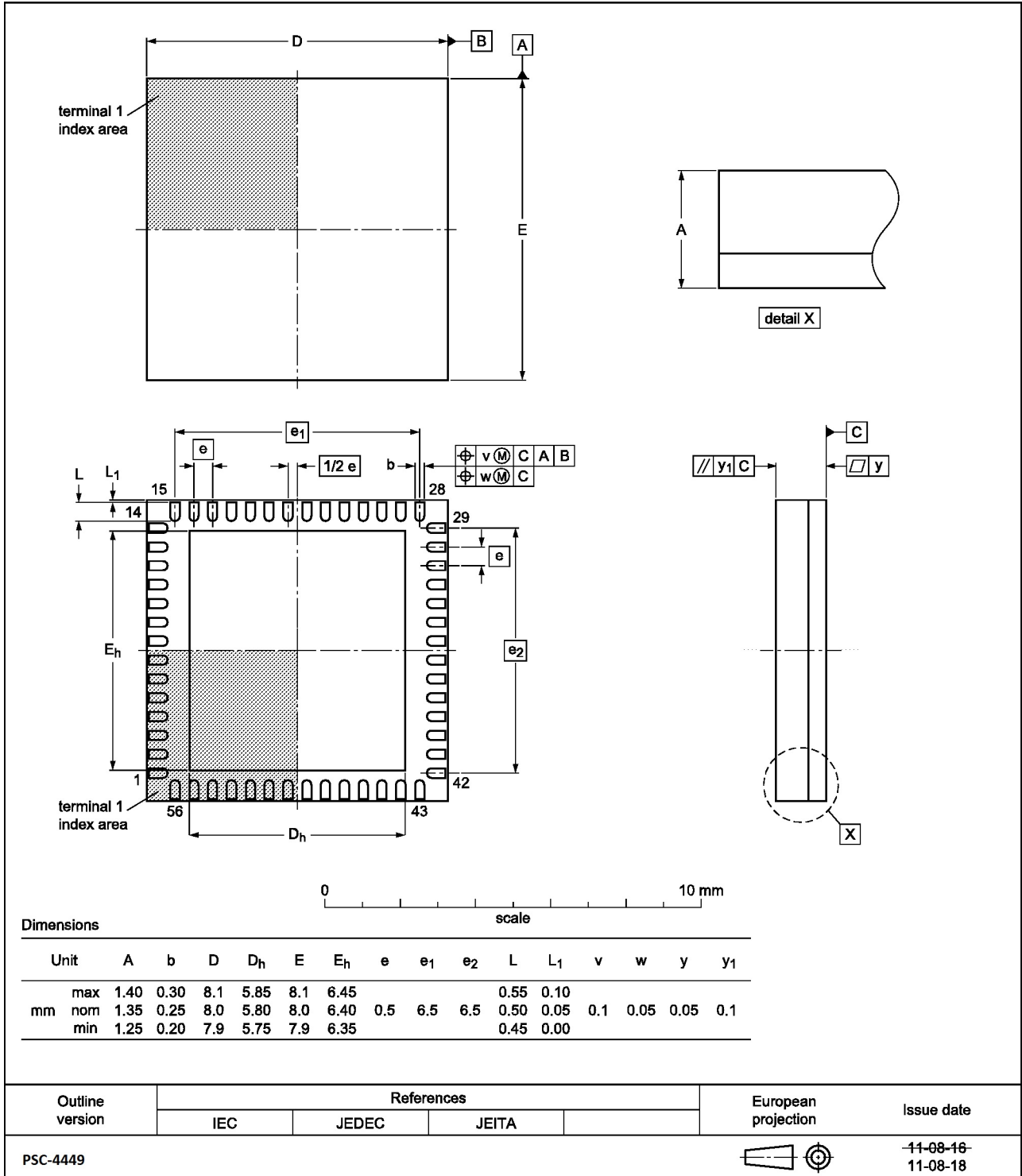

Fig 43. Package outline PSC-4449 (VFQFPN56)

## 13. Abbreviations

**Table 65. Abbreviations**

Acronym	Description
ADC	Analog-to-Digital Converter
CDMA	Code Division Multiple Access
DAV	DAta Valid
ESD	ElectroStatic Discharge
FFT	Fast Fourier Transform
GSM	Global System for Mobile communications
ILA	Initial Lane Alignment
IMD3	third order InterMoDulation product
LSB	Least Significant Bit
LTE	Long-Term Evolution
LVDS DDR	Low Voltage Differential Signaling Double Data Rate
LVPECL	Low-Voltage Positive Emitter-Coupled Logic
MIMO	Multiple Input Multiple Output
MSB	Most Significant Bit
OTR	OuT-of-Range
SFDR	Spurious-Free Dynamic Range
SPI	Serial Peripheral Interface
SNR	Signal-to-Noise Ratio
TD-SCDMA	Time Division-Synchronous Code Division Multiple Access
WCDMA	Wideband Code Division Multiple Access
WiMAX	Worldwide interoperability for Microwave Access
Tclk	Period of the Sampling Clock

## 14. Revision history

Table 66. Revision history

Document ID	Release date	Data sheet status	Change notice	Supersedes
ADC1443D_SER v.4.4	20140606	Product data sheet	- Parameter K added - Offset error updated	ADC1443D_SER v.4.3
ADC1443D_SER v.4.3	20131113	Product data sheet	Registers updated	ADC1443D_SER v.4.2
ADC1443D_SER v.4.2	20130402	Product data sheet	new package outline	ADC1443D_SER v.4.1
ADC1443D_SER v.4.1	20130227	Product data sheet	-	ADC1443D_SER v.4.0
ADC1443D_SER v.4.0	20130213	Product data sheet	-	ADC1443D_SER v.3.6
ADC1443D_SER v.3.6	20130208	Data sheet	-	ADC1443D_SER v.3.5
ADC1443D_SER v.3.5	20130111	Data sheet	-	ADC1443D_SER v.3.4
ADC1443D_SER v.3.4	20121010	Data sheet	-	ADC1443D_SER v.3.3
ADC1443D_SER v.3.3	20120926	Objective data sheet	-	ADC1443D_SER v.3.2
ADC1443D_SER v.3.2	20120918	Objective data sheet	-	ADC1443D_SER v.3.1
ADC1443D_SER v.3.1	20120911	Objective data sheet	-	ADC1443D_SER v.3.0
ADC1443D_SER v.3.0	20120901	Objective data sheet	-	ADC1443D_SER v.2.0
Modifications:	<ul style="list-style-type: none"> <li>• Text and drawings updated throughout entire data sheet.</li> </ul>			
ADC1443D_SER v.2.0	20120630	Objective data sheet	-	ADC1443D_SER v.1.1
ADC1443D_SER v.1.1	20110928	Objective data sheet	-	ADC1443D_SER v.1
ADC1443D_SER v.1	20110901	Objective data sheet	-	-

## Contact information



[www.IDT.com](http://www.IDT.com)

6024 Silver Creek Valley Road  
San Jose, California 95138

## 15. Contents

<b>1</b>	<b>General description</b> . . . . .	<b>1</b>	11.2.4	JESD204B Deterministic Latency (pins SYSREFN and SYSREFP or SYNCBP and SYNCBN) . . . . .	25
<b>2</b>	<b>Features and benefits</b> . . . . .	<b>1</b>	11.3	Digital outputs . . . . .	26
<b>3</b>	<b>Applications</b> . . . . .	<b>2</b>	11.3.1	Digital output buffers . . . . .	26
<b>4</b>	<b>Ordering information</b> . . . . .	<b>2</b>	11.3.2	JESD204A/JESD204B serializer . . . . .	26
<b>5</b>	<b>Block diagram</b> . . . . .	<b>3</b>	11.3.2.1	Digital JESD204A/JESD204B formatter . . . . .	26
<b>6</b>	<b>Pinning information</b> . . . . .	<b>4</b>	11.3.2.2	Scrambler (SCR_EN) . . . . .	28
6.1	Pinning . . . . .	4	11.3.3	OuT-of-Range (OTR) . . . . .	28
6.2	Pin description . . . . .	5	11.3.4	Digital offset . . . . .	28
6.2.1	Start-up Configuration . . . . .	6	11.3.5	Test patterns . . . . .	29
<b>7</b>	<b>Limiting values</b> . . . . .	<b>7</b>	11.3.6	Output data format selection . . . . .	29
<b>8</b>	<b>Thermal characteristics</b> . . . . .	<b>7</b>	11.3.7	Output codes versus input voltage . . . . .	29
<b>9</b>	<b>Static characteristics</b> . . . . .	<b>7</b>	11.4	Configuration pins (CFG0, CFG1, CFG2, CFG3) . . . . .	30
<b>10</b>	<b>Dynamic characteristics</b> . . . . .	<b>10</b>	11.5	Serial Peripheral Interface (SPI) . . . . .	32
10.1	Dynamic characteristics . . . . .	10	11.5.1	Register description . . . . .	32
10.2	Timing . . . . .	12	11.5.2	Start-up programing . . . . .	34
10.2.1	Clock timing . . . . .	12	11.5.3	Register allocation map . . . . .	35
10.2.2	SYSREFP/N and SYNCBP/N timings . . . . .	12	11.5.4	Detailed register description . . . . .	38
10.2.3	SPI timing . . . . .	13	11.5.4.1	ADC control registers . . . . .	38
10.3	Typical dynamic performances . . . . .	14	11.5.4.2	JESD204A/JESD204B control registers . . . . .	42
10.3.1	Typical FFT at 122.88 Msps . . . . .	14	<b>12</b>	<b>Package outline</b> . . . . .	<b>49</b>
10.3.2	Typical FFT at 153.6 Msps . . . . .	15	<b>13</b>	<b>Abbreviations</b> . . . . .	<b>50</b>
10.3.3	Typical FFT at 184.32 Msps . . . . .	16	<b>14</b>	<b>Revision history</b> . . . . .	<b>51</b>
10.3.4	Typical SNR performances . . . . .	17	<b>15</b>	<b>Contents</b> . . . . .	<b>52</b>
10.3.5	Typical SFDR performances . . . . .	18			
10.3.6	Typical IMD3 performances . . . . .	19			
<b>11</b>	<b>Application information</b> . . . . .	<b>20</b>			
11.1	Analog inputs . . . . .	20			
11.1.1	Input stage . . . . .	20			
11.1.2	Common-mode input voltage ( $V_{I(cm)}$ ) . . . . .	20			
11.1.3	Pin VCM . . . . .	20			
11.1.4	Programmable full-scale . . . . .	21			
11.1.5	Anti-kickback circuitry . . . . .	21			
11.1.6	Transformer . . . . .	22			
11.2	Clock input . . . . .	23			
11.2.1	Drive modes . . . . .	23			
11.2.2	Equivalent input circuit . . . . .	24			
11.2.3	JESD204B harmonic clocking . . . . .	24			

### Disclaimer

Integrated Device Technology, Inc. (IDT) and its subsidiaries reserve the right to modify the products and/or specifications described herein at any time and at IDT's sole discretion. All information in this document, including descriptions of product features and performance, is subject to change without notice. Performance specifications and the operating parameters of the described products are determined in the independent state and are not guaranteed to perform the same way when installed in customer products. The information contained herein is provided without representation or warranty of any kind, whether express or implied, including, but not limited to, the suitability of IDT's products for any particular purpose, an implied warranty of merchantability, or non-infringement of the intellectual property rights of others. This document is presented only as a guide and does not convey any license under intellectual property rights of IDT or any third parties.

IDT's products are not intended for use in life support systems or similar devices where the failure or malfunction of an IDT product can be reasonably expected to significantly affect the health or safety of users. Anyone using an IDT product in such a manner does so at their own risk, absent an express, written agreement by IDT.

Integrated Device Technology, IDT and the IDT logo are registered trademarks of IDT. Other trademarks and service marks used herein, including protected names, logos and designs, are the property of IDT or their respective third party owners.

Copyright, 2014. All rights reserved.

# Mouser Electronics

Authorized Distributor

Click to View Pricing, Inventory, Delivery & Lifecycle Information:

[IDT \(Integrated Device Technology\):](#)

[ADC1443D160HD-C1](#) [ADC1443D200HD-C1](#) [ADC1443D125HD-C1](#) [ADC1443D160HD-C18](#)