

Features

- Supports the requirements of ITU-T G.8262 for synchronous Ethernet Equipment slave Clocks (EEC option 1 and 2)
- Supports the requirements of Telcordia GR-1244 Stratum 3 and GR-253, ITU-T G.812, G.813
- Supports ITU-T G.823, G.824 and G.8261 for 2048 kbit/s and 1544 kbit/s interfaces
- Meets the SONET/SDH jitter generation requirements up to OC-48/STM-16
- Synchronizes to telecom reference clocks (2 kHz, N*8 kHz up to 77.76 MHz, 155.52 MHz) or to Ethernet reference clocks (25 MHz, 50 MHz, 62.5 MHz, 125 MHz)
- Generates standard SONET/SDH clock rates (e.g., 19.44 MHz, 38.88 MHz, 77.76 MHz, 155.52 MHz, 622.08 MHz) or Ethernet clock rates (e.g., 25 MHz, 50 MHz, 125 MHz, 156.25 MHz, 312.5 MHz) for synchronizing Gigabit Ethernet PHYs
- Programmable output synthesizer generates telecom clock frequencies from any multiple of 8 kHz up to 100 MHz
- Generates several styles of telecom frame pulses with selectable pulse width, polarity and frequency
- Internal state machine automatically controls mode of operation (free-run, locked, holdover)

Ordering Information

ZL30142GGG 64 Pin CABGA Trays
 ZL30142GGG2 64 Pin CABGA* Trays

*Pb Free Tin/Silver/Copper

-40°C to +85°C

- Flexible input reference monitoring automatically disqualifies references based on frequency and phase irregularities
- Provides automatic reference switching and holdover during loss of reference input
- Supports master/slave configuration and dynamic input to output delay compensation for AdvancedTCA™
- Configurable input to output delay and output to output phase alignment

Applications

- ITU-T G.8262 System Timing Cards which support 1 GbE interfaces
- Telcordia GR-253 Carrier Grade SONET/SDH Stratum 3 System Timing Cards

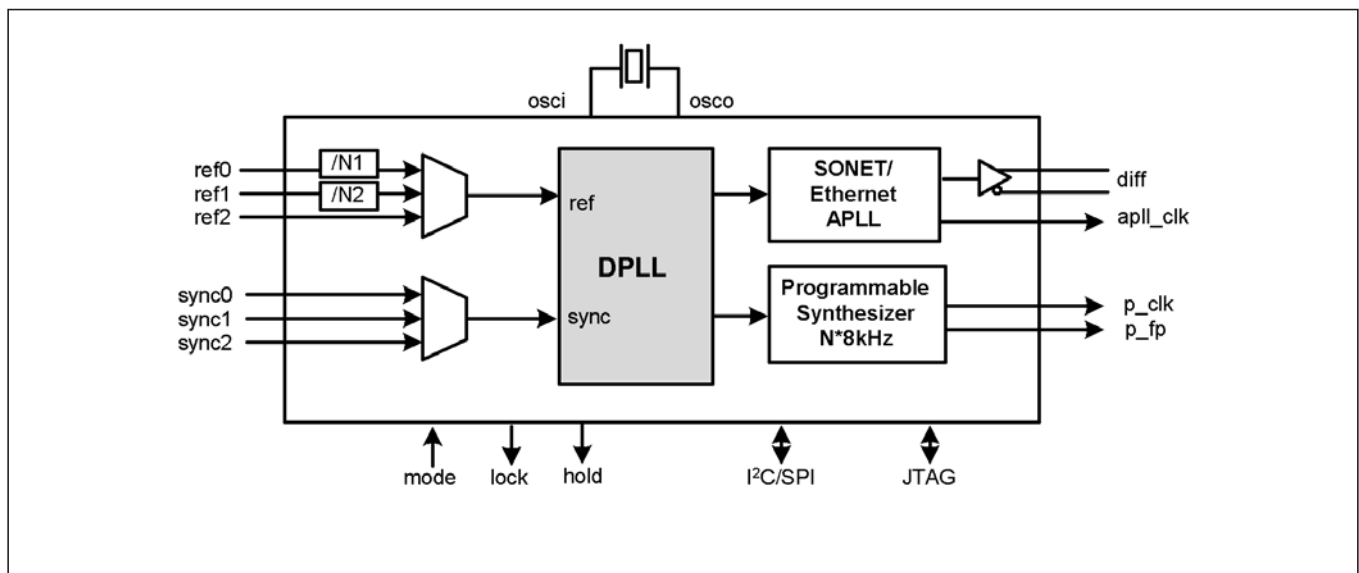

Figure 1 - Functional Block Diagram

1.0 High Level Overview

The ZL30142 SONET/SDH/GbE Stratum 3 System Synchronizer and SETS device is a highly integrated device that provides all of the functionality that is required for a central timing card in carrier grade network equipment. The basic functions of a central timing card include:

- Input reference monitoring for both frequency accuracy and phase irregularities
- Automatic input reference selection
- Support of both external timing and line timing modes
- Hitless reference switching
- Wander and jitter filtering
- Master/slave crossover for minimizing phase alignment between redundant timing cards
- Independent derived output timing path for support of the SETS functionality

In a typical application, the main timing path uses the DPLL to synchronize to either an external BITS source or to a recovered line timed source. The DPLL monitors the references and automatically selects the best available reference based on configurable priority and revertive properties. the DPLL provides the wander filtering function and the P0 synthesizer generates a jitter filtered clock and frame pulse for the system timing bus which supplies all line cards with a common timing reference.

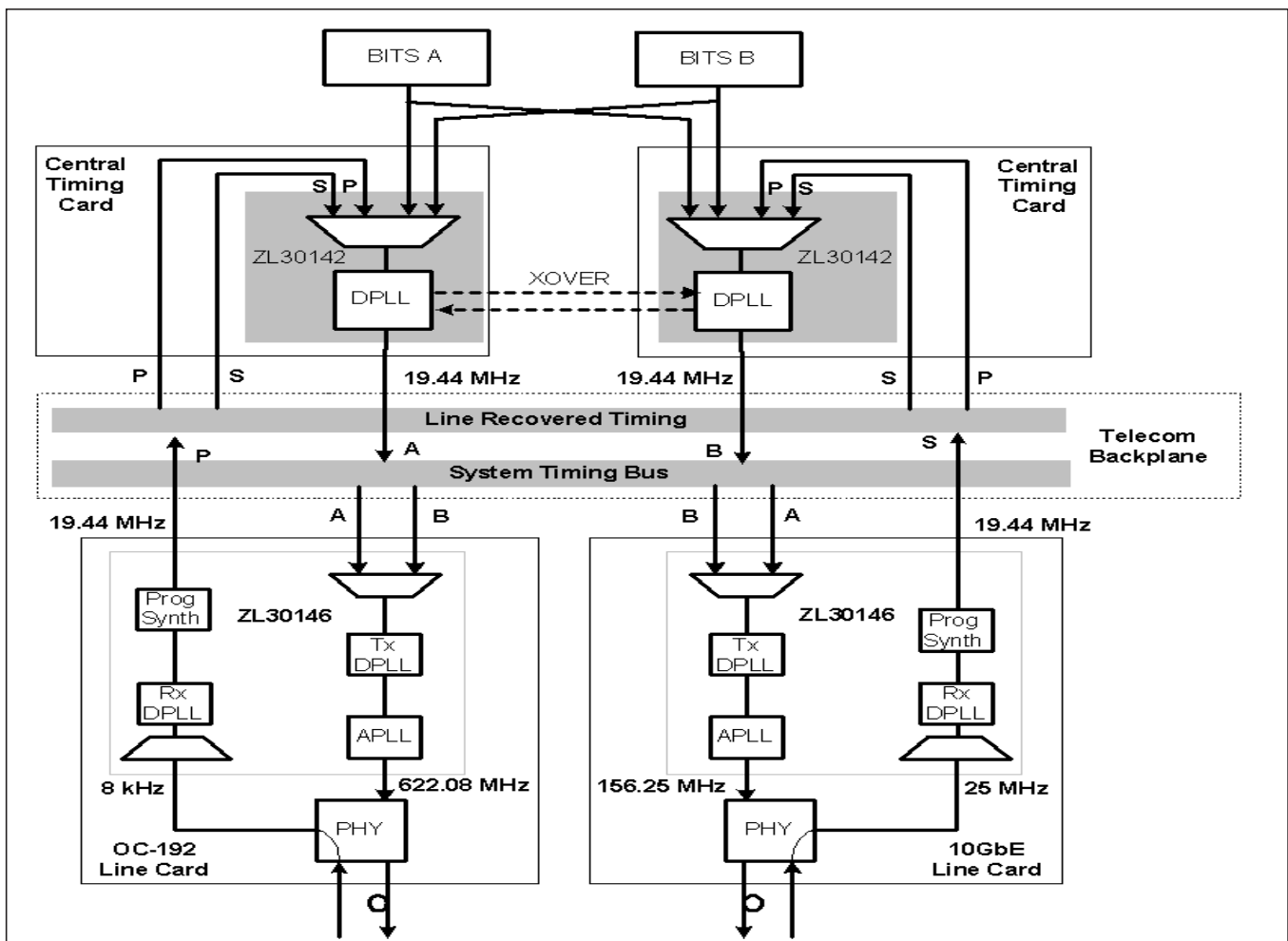

Figure 2 - Typical Application of the ZL30142

Information relating to products and services furnished herein by Microsemi Corporation or its subsidiaries (collectively "Microsemi") is believed to be reliable. However, Microsemi assumes no liability for errors that may appear in this publication, or for liability otherwise arising from the application or use of any such information, product or service or for any infringement of patents or other intellectual property rights owned by third parties which may result from such application or use. Neither the supply of such information or purchase of product or service conveys any license, either express or implied, under patents or other intellectual property rights owned by Microsemi or licensed from third parties by Microsemi, whatsoever. Purchasers of products are also hereby notified that the use of product in certain ways or in combination with Microsemi, or non-Microsemi furnished goods or services may infringe patents or other intellectual property rights owned by Microsemi.

This publication is issued to provide information only and (unless agreed by Microsemi in writing) may not be used, applied or reproduced for any purpose nor form part of any order or contract nor to be regarded as a representation relating to the products or services concerned. The products, their specifications, services and other information appearing in this publication are subject to change by Microsemi without notice. No warranty or guarantee express or implied is made regarding the capability, performance or suitability of any product or service. Information concerning possible methods of use is provided as a guide only and does not constitute any guarantee that such methods of use will be satisfactory in a specific piece of equipment. It is the user's responsibility to fully determine the performance and suitability of any equipment using such information and to ensure that any publication or data used is up to date and has not been superseded. Manufacturing does not necessarily include testing of all functions or parameters. These products are not suitable for use in any medical and other products whose failure to perform may result in significant injury or death to the user. All products and materials are sold and services provided subject to Microsemi's conditions of sale which are available on request.

**For more information about all Microsemi products
visit our website at
www.microsemi.com**

TECHNICAL DOCUMENTATION – NOT FOR RESALE



Microsemi Corporate Headquarters
One Enterprise, Aliso Viejo CA 92656 USA
Within the USA: +1 (949) 380-6100
Sales: +1 (949) 380-6136
Fax: +1 (949) 215-4996

Microsemi Corporation (NASDAQ: MSCC) offers a comprehensive portfolio of semiconductor solutions for: aerospace, defense and security; enterprise and communications; and industrial and alternative energy markets. Products include high-performance, high-reliability analog and RF devices, mixed signal and RF integrated circuits, customizable SoCs, FPGAs, and complete subsystems. Microsemi is headquartered in Aliso Viejo, Calif. Learn more at www.microsemi.com.

© 2013 Microsemi Corporation. All rights reserved. Microsemi and the Microsemi logo are trademarks of Microsemi Corporation. All other trademarks and service marks are the property of their respective owners.