

MC12095

2.5 GHz Low Power Prescaler With Stand-By Mode

The MC12095 is a single modulus prescaler for low power frequency division of a 2.5 GHz high frequency input signal. MOSAIC V™ technology is utilized to achieve low power dissipation of 24 mW at a minimum supply voltage of 2.7 V.

On-chip output termination provides output current to drive a 2.0 pF (typical) high impedance load. If additional drive is required for the prescaler output, an external resistor can be added in parallel from the OUT pin to GND to increase the output power. Care must be taken not to exceed the maximum allowable current through the output.

Divide ratio control input (SW) selects the required divide ratio of ÷2 or ÷4. Stand-By mode is available to reduce current drain to 100 µA typical when the standby pin SB is switched LOW disabling the prescaler.

Features

- 2.5 GHz Toggle Frequency
- Supply Voltage 2.7 V to 5.5 Vdc
- Low Power 8.7 mA Typical
- Operating Temperature -40 to 85°C
- Divide by 2 or 4 Selected by the SW Pin

FUNCTIONAL TABLE

SW	Divide Ratio
H	2
L	4

1. SW: H = ($V_{CC} - 0.4$ V) to V_{CC} ; L = OPEN
2. SB: H = 2.0 V to V_{CC} ; L = GND to 0.8 V

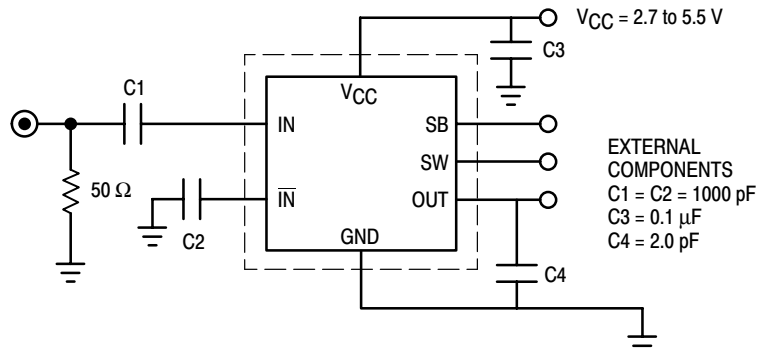

Figure 1. AC Test Circuit



ON Semiconductor™

<http://onsemi.com>

MARKING DIAGRAM



A = Assembly Location
L = Wafer Lot
Y = Year
W = Work Week

PIN CONNECTIONS

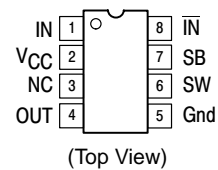

ORDERING INFORMATION

Device	Package	Shipping
MC12095D	SO-8	96 Units/Rail
MC12095DR2	SO-8	2500 Tape & Reel

MC12095

MAXIMUM RATINGS

Rating	Symbol	Value	Unit
Power Supply Voltage, Pin 2	V_{CC}	-0.5 to 6.0	Vdc
Operating Temperature Range	T_A	-40 to 85	°C
Storage Temperature Range	T_{stg}	-65 to 150	°C
Maximum Output Current, Pin 4	I_O	8.0	mA

NOTE: ESD data available upon request.

ELECTRICAL CHARACTERISTICS ($V_{CC} = 2.7$ to 5.5 V; $T_A = -40$ to 85°C , unless otherwise noted.)

Characteristic	Symbol	Min	Typ	Max	Unit	
Toggle Frequency (Sine Wave)	f_t	500	3.0	2.5	GHz	
Supply Current	I_{CC}	-	8.7	14	mA	
Stand-By Current	I_{SB}	-	100	200	μA	
Stand-By Input HIGH (SB)	V_{IH1}	2.0	-	$V_{CC} + 0.5$ V	V	
Stand-By Input LOW (SB)	V_{IL1}	GND	-	0.8	V	
Divide Ratio Control Input HIGH (SW)	V_{IH2}	$V_{CC} - 0.4$	V_{CC}	$V_{CC} + 0.5$ V	V	
Divide Ratio Control Input LOW (SW)	V_{IL2}	OPEN	OPEN	OPEN		
Output Voltage Swing (2pF Load)	V_{OUT}	500–1000 MHz Input	800	-	-	mVpp
1000–1500 MHz Input		400	450	-		
1500–2500 MHz Input		200	250	-		
Input Voltage Sensitivity	V_{IN}	200	-	1000	mVpp	

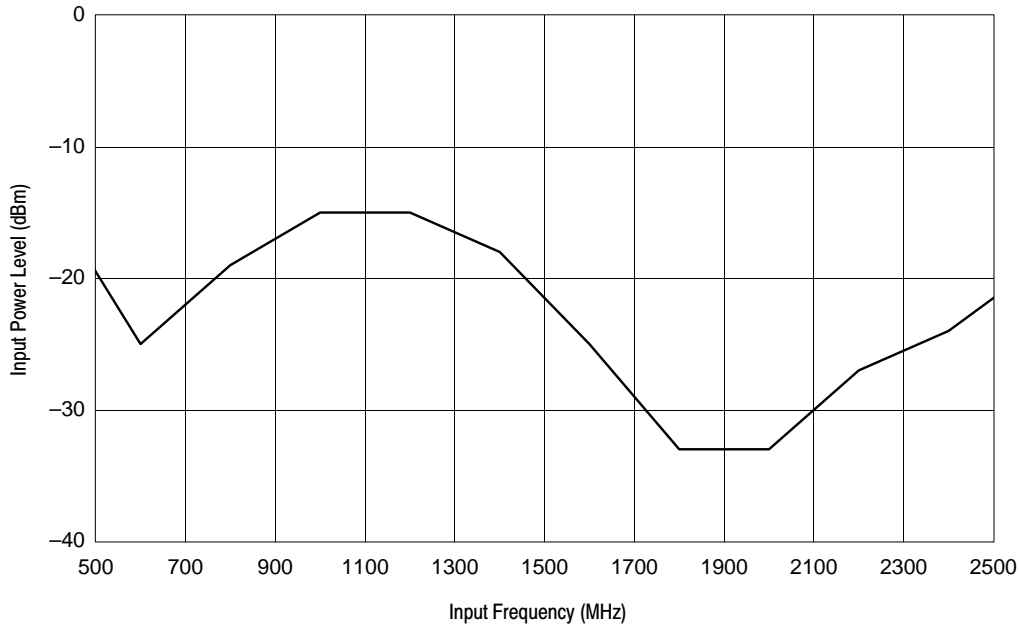

(Divide By 2 Mode, $T = 25^\circ\text{C}$, $V_{CC} = 2.7$ V)

Figure 2. Typical Minimum Input Sensitivity versus Input Frequency