

## General Description

The 8741004 is a high performance Differential-to-LVDS/0.7V Differential Jitter Attenuator designed for use in PCI Express™ systems. In some PCI Express systems, such as those found in desktop PCs, the PCI Express clocks are generated from a low bandwidth, high phase noise PLL frequency synthesizer. In these systems, a jitter attenuator may be required to attenuate high frequency random and deterministic jitter components from the PLL synthesizer and from the system board. The 8741004 has 3 PLL bandwidth modes: 200kHz, 600kHz and 2MHz. The 200kHz mode will provide maximum jitter attenuation, but with higher PLL tracking skew and spread spectrum modulation from the motherboard synthesizer may be attenuated. The 600kHz provides an intermediate bandwidth that can easily track triangular spread profiles, while providing good jitter attenuation. The 2MHz bandwidth provides the best tracking skew and will pass most spread profiles, but the jitter attenuation will not be as good as the lower bandwidth modes. Because some 2.5Gb serdes have x20 multipliers while others have x25 multipliers, the 8741004 can be set for 1:1 mode or 5/4 multiplication mode (i.e. 100MHz input/125MHz output) using the F\_SEL pins.

The 8741004 uses IDT's 3<sup>rd</sup> Generation FemtoClock™ PLL technology to achieve the lowest possible phase noise. The device is packaged in a 24 Lead TSSOP package, making it ideal for use in space constrained applications such as PCI Express add-in cards.

### PLL Bandwidth

<p>BW_SEL                  0 = PLL Bandwidth: ~200kHz                  Float = PLL Bandwidth: ~600kHz (default)                  1 = PLL Bandwidth: ~2MHz</p>
---------------------------------------------------------------------------------------------------------------------------------------------------------------------------

## Features

- Two LVDS and two 0.7V differential output pairs  
Bank A has two LVDS output pairs and  
Bank B has two 0.7V differential output pairs
- One differential clock input pair
- CLK,  $\overline{\text{CLK}}$  pair can accept the following differential input levels: LVPECL, LVDS, LVHSTL, SSTL, HCSL
- Output frequency range: 98MHz - 160MHz
- Input frequency range: 98MHz - 128MHz
- VCO range: 490MHz - 640MHz
- Cycle-to-cycle jitter: 35ps (maximum)
- Full 3.3V operating supply
- Three bandwidth modes allow the system designer to make jitter attenuation/tracking skew design trade-offs
- 0°C to 70°C ambient operating temperature
- Available in lead-free (RoHS 6) package

## Pin Assignment

nQA1	1	24	nQB1
QA1	2	23	QB1
V <sub>DDO</sub>	3	22	V <sub>DDO</sub>
QA0	4	21	QB0
nQA0	5	20	nQB0
MR	6	19	IREF
BW_SEL	7	18	F_SELB
nc	8	17	OEB
V <sub>DDA</sub>	9	16	GND
F_SELA	10	15	GND
V <sub>DD</sub>	11	14	nCLK
OEA	12	13	CLK

**8741004**

**24-Lead TSSOP**

**4.4mm x 7.8mm x 0.925mm**

**package body**

**G Package**

**Top View**

## Block Diagram

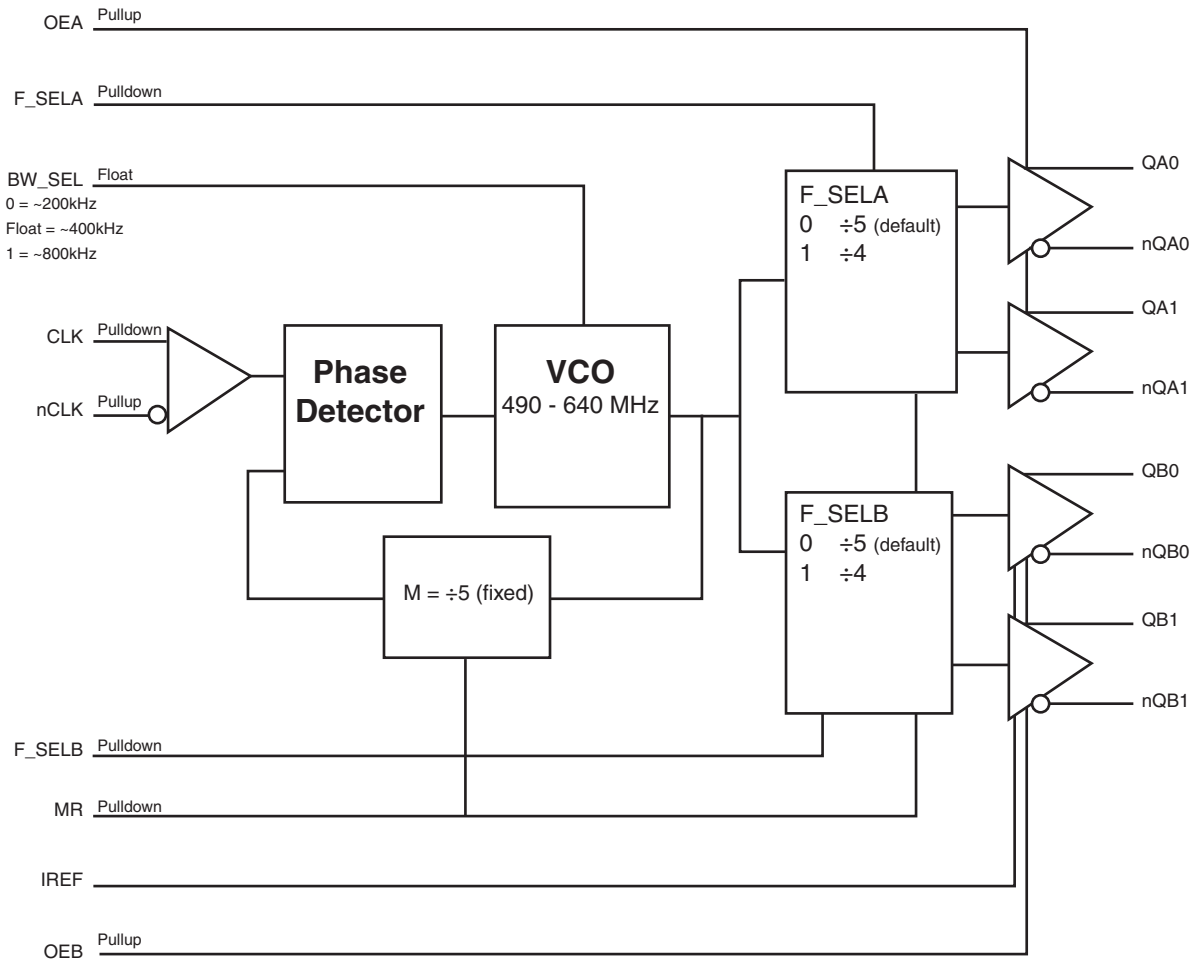

**Table 1. Pin Descriptions**

Number	Name	Type		Description
1, 2	$\overline{QA1}$ , QA1	Output		Differential output pair. LVDS interface levels.
3, 22	V <sub>DDO</sub>	Power		Output supply pins.
4, 5	QA0, $\overline{QA0}$	Output		Differential output pair. LVDS interface levels.
6	MR	Input	Pulldown	Active High Master Reset. When logic HIGH, the internal dividers are reset causing the true outputs Q[Ax:Bx] to go LOW and the inverted outputs $\overline{Q[Ax:Bx]}$ to go HIGH. When logic LOW, the internal dividers and the outputs are enabled. LVCMOS/LVTTL interface levels.
7	BW_SEL	Input	Pullup/ Pulldown	PLL Bandwidth input. LVCMOS/LVTTL interface levels. See Table 3B.
8	nc	Unused		No connect.
9	V <sub>DDA</sub>	Power		Analog supply pin.
10	F_SELA	Input	Pulldown	Frequency select pins for QAx/ $\overline{QAx}$ outputs. LVCMOS/LVTTL interface levels. See Table 3C.
11	V <sub>DD</sub>	Power		Core supply pin.
12	OEA	Input	Pullup	Output enable for QAx pins. When HIGH, QAx/ $\overline{QAx}$ outputs are enabled. When LOW, the QAx/ $\overline{QAx}$ outputs are in a high impedance state. LVCMOS/LVTTL interface levels. See Table 3A.
13	CLK	Input	Pulldown	Non-inverting differential clock input.
14	$\overline{CLK}$	Input	Pullup	Inverting differential clock input.
15, 16	GND	Power		Power supply ground.
17	OEB	Input	Pullup	Output enable for QBx pins. When HIGH, QBx/ $\overline{QBx}$ outputs are enabled. When LOW, the QBx/ $\overline{QBx}$ outputs are in a high impedance state. LVCMOS/LVTTL interface levels. See Table 3A.
18	F_SELB	Input	Pulldown	Frequency select pins for QBx/ $\overline{QBx}$ outputs. LVCMOS/LVTTL interface levels. See Table 3C.
19	IREF	Input		A fixed precision resistor (RREF = 475Ω) from this pin to ground provides a reference current used for differential current-mode QB0/nQB0 clock outputs.
20, 21	$\overline{QB0}$ , QB0	Output		Differential output pair. HCSL interface levels.
23, 24	QB1, $\overline{QB1}$	Output		Differential output pair. HCSL interface levels.

NOTE: Pullup and Pulldown refer to internal input resistors. See Table 2, Pin Characteristics, for typical values.

**Table 2. Pin Characteristics**

Symbol	Parameter	Test Conditions	Minimum	Typical	Maximum	Units
C <sub>IN</sub>	Input Capacitance			4		pF
R <sub>PULLUP</sub>	Input Pullup Resistor			51		kΩ
R <sub>PULLDOWN</sub>	Input Pulldown Resistor			51		kΩ

## Function Tables

**Table 3A. Output Enable Function Table**

Inputs		Outputs	
OEA	OEB	QA[0:1]/ $\overline{\text{QA}}[0:1]$	QB[0:1]/ $\overline{\text{QB}}[0:1]$
0	0	Hi-Z	Hi-Z
1	1	Enabled	Enabled

**Table 3B. PLL Bandwidth Function Table**

Input	PLL Bandwidth
BW_SEL	
0	~200kHz
Float	~600kHz (default)
1	~2MHz

**Table 3C. Frequency Select Table**

Inputs	Divider
F_SEL[A, B]	
0	÷5 (default)
1	÷4

## Absolute Maximum Ratings

NOTE: Stresses beyond those listed under *Absolute Maximum Ratings* may cause permanent damage to the device. These ratings are stress specifications only. Functional operation of product at these conditions or any conditions beyond those listed in the *DC Characteristics* or *AC Characteristics* is not implied. Exposure to absolute maximum rating conditions for extended periods may affect product reliability.

Item	Rating
Supply Voltage, $V_{DD}$	4.6V
Inputs, $V_I$	-0.5V to $V_{DD} + 0.5V$
Outputs, $V_O$	-0.5V to $V_{DDO} + 0.5V$
Package Thermal Impedance, $\theta_{JA}$	82.3°C/W (0 mps)
Storage Temperature, $T_{STG}$	-65°C to 150°C

## DC Electrical Characteristics

**Table 4A. Power Supply DC Characteristics,  $V_{DD} = V_{DDO} = 3.3V \pm 5\%$ ,  $T_A = 0^\circ\text{C}$  to  $70^\circ\text{C}$**

Symbol	Parameter	Test Conditions	Minimum	Typical	Maximum	Units
$V_{DD}$	Core Supply Voltage		3.135	3.3	3.465	V
$V_{DDA}$	Analog Supply Voltage		$V_{DD} - 0.12$	3.3	$V_{DD}$	V
$V_{DDO}$	Output Supply Voltage		3.135	3.3	3.465	V
$I_{DD}$	Power Supply Current				45	mA
$I_{DDA}$	Analog Supply Current				12	mA
$I_{DDO}$	Output Supply Current				80	mA

**Table 4B. LVCMOS/LVTTL DC Characteristics,  $V_{DD} = V_{DDO} = 3.3V \pm 5\%$ ,  $T_A = 0^\circ C$  to  $70^\circ C$** 

Symbol	Parameter	Test Conditions	Minimum	Typical	Maximum	Units
$V_{IH}$	Input High Voltage	OEA, OEB, MR, F_SELA, F_SELB	2		$V_{DD} + 0.3$	V
		BW_SEL	$V_{DD} - 0.3$		$V_{DD} + 0.3$	V
$V_{IL}$	Input Low Voltage	OEA, OEB, MR, F_SELA, F_SELB	-0.3		0.8	V
		BW_SEL	-0.3		+0.3	V
$V_{IM}$	Input Mid Voltage	BW_SEL	$V_{DD}/2 - 0.1$		$V_{DD}/2 + 0.1$	V
$I_{IH}$	Input High Current	F_SELA, F_SELB, MR, BW_SEL	$V_{DD} = V_{IN} = 3.465V$		150	$\mu A$
		OEA, OEB	$V_{DD} = V_{IN} = 3.465V$		5	$\mu A$
$I_{IL}$	Input Low Current	MR, F_SELA, F_SELB,	$V_{DD} = 3.465V, V_{IN} = 0V$	-5		$\mu A$
		OEA, OEB, BW_SEL	$V_{DD} = 3.465V, V_{IN} = 0V$	-150		$\mu A$

**Table 4C. Differential DC Characteristics,  $V_{DD} = V_{DDO} = 3.3V \pm 5\%$ ,  $T_A = 0^\circ C$  to  $70^\circ C$** 

Symbol	Parameter	Test Conditions	Minimum	Typical	Maximum	Units
$I_{IH}$	Input High Current	CLK	$V_{DD} = V_{IN} = 3.465V$		150	$\mu A$
		$\overline{CLK}$	$V_{DD} = V_{IN} = 3.465V$		5	$\mu A$
$I_{IL}$	Input Low Current	CLK	$V_{DD} = 3.465V,$ $V_{IN} = 0V$	-5		$\mu A$
		$\overline{CLK}$	$V_{DD} = 3.465V,$ $V_{IN} = 0V$	-150		$\mu A$
$V_{PP}$	Peak-to-Peak Voltage; NOTE 1		0.15		1.3	V
$V_{CMR}$	Common Mode Input Voltage; NOTE 1, 2		GND + 0.5		$V_{DD} - 0.85$	V

NOTE 1:  $V_{IL}$  should not be less than -0.3V

NOTE 2: Common mode input voltage is defined as  $V_{IH}$ .

**Table 4D. LVDS DC Characteristics,  $V_{DD} = V_{DDO} = 3.3V \pm 5\%$ ,  $T_A = 0^\circ C$  to  $70^\circ C$** 

Symbol	Parameter	Test Conditions	Minimum	Typical	Maximum	Units
$V_{OD}$	Differential Output Voltage		290	390	490	mV
$\Delta V_{OD}$	$V_{OD}$ Magnitude Change				50	mV
$V_{OS}$	Offset Voltage		1.2	1.35	1.5	V
$\Delta V_{OS}$	$V_{OS}$ Magnitude Change				50	mV

## AC Electrical Characteristics

Table 5. 0.7V Differential AC Characteristics,  $V_{DD} = V_{DDO} = 3.3V \pm 5\%$ ,  $T_A = 0^\circ C$  to  $70^\circ C$

Parameter	Symbol	Test Conditions	Minimum	Typical	Maximum	Units
$f_{MAX}$	Output Frequency		98		160	MHz
$f_{jit(cc)}$	Cycle-to-Cycle Jitter; NOTE 1				35	ps
$t_{sk(b)}$	Bank Skew; NOTE 2				30	ps
$V_{HIGH}$	Output Voltage High	QBx/ $\overline{QBx}$	530		870	mV
$V_{LOW}$	Output Voltage Low	QBx/ $\overline{QBx}$	-150			mV
$V_{OVS}$	Max. Voltage, Overshoot	QBx/ $\overline{QBx}$			$V_{HIGH} + 0.35$	V
$V_{UDS}$	Min. Voltage, Undershoot	QBx/ $\overline{QBx}$	-0.3			V
$V_{rb}$	Ringback Voltage	QBx/ $\overline{QBx}$			0.2	V
$V_{CROSS}$	Absolute Crossing Voltage	QBx/ $\overline{QBx}$	@ 0.7V Swing	250	550	mV
$\Delta V_{CROSS}$	Total Variation of $V_{CROSS}$ over all edges	QBx/ $\overline{QBx}$	@ 0.7V Swing		140	mV
$t_R / t_F$	Output Rise/Fall Time	QBx/ $\overline{QBx}$	measured between 0.175V to 0.525V	175	700	ps
		QAx/ $\overline{QAx}$	20% to 80%	250	600	ps
$\Delta t_R / \Delta t_F$	Rise/Fall Time Variation	QBx/ $\overline{QBx}$			125	ps
$t_{RFM}$	Rise/Fall Matching	QBx/ $\overline{QBx}$			20	%
odc	Output Duty Cycle		48		52	%

NOTE 1: This parameter is defined in accordance with JEDEC Standard 65.

NOTE 2: Defined as skew within a bank of outputs at the same voltage and with equal load conditions.

## Parameter Measurement Information

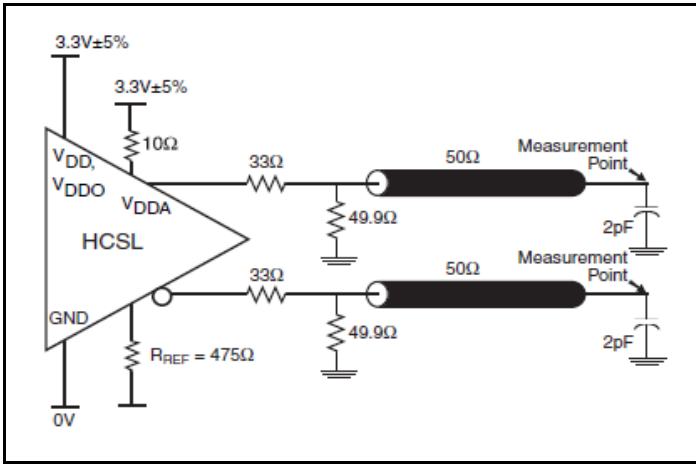

3.3V HCSL Output Load AC Test Circuit

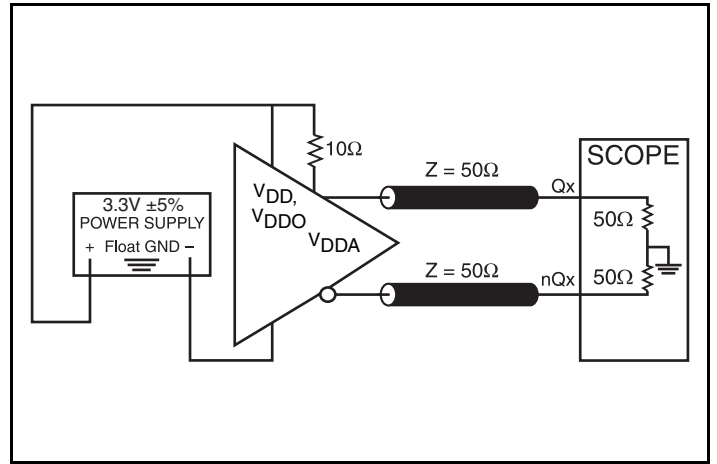

3.3V LVDS Output Load AC Test Circuit

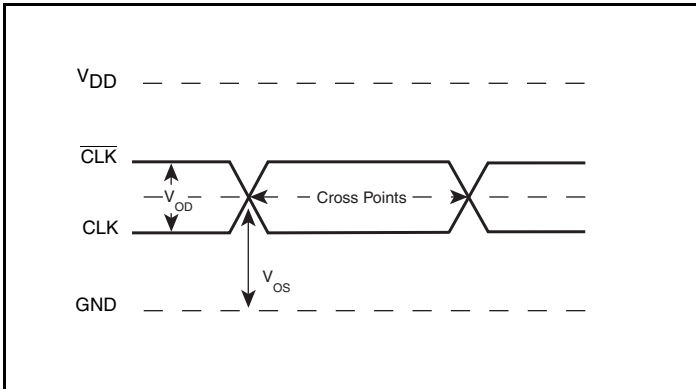

Differential Input Level

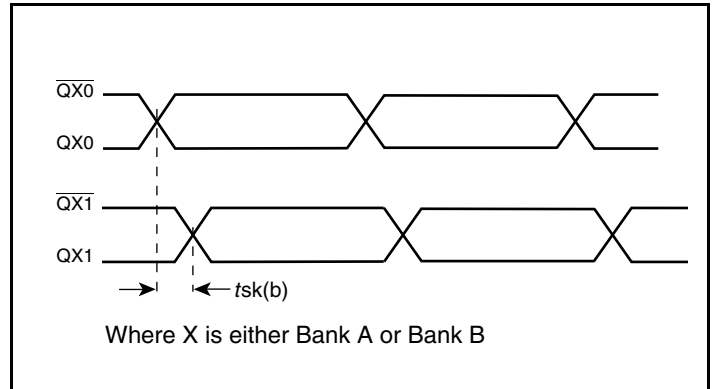

Bank Skew

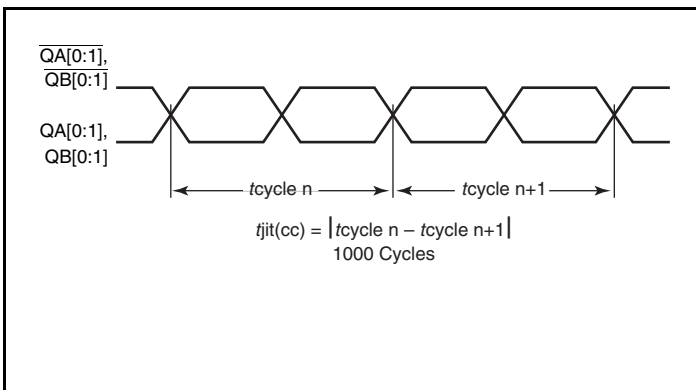

Cycle-to-Cycle Jitter

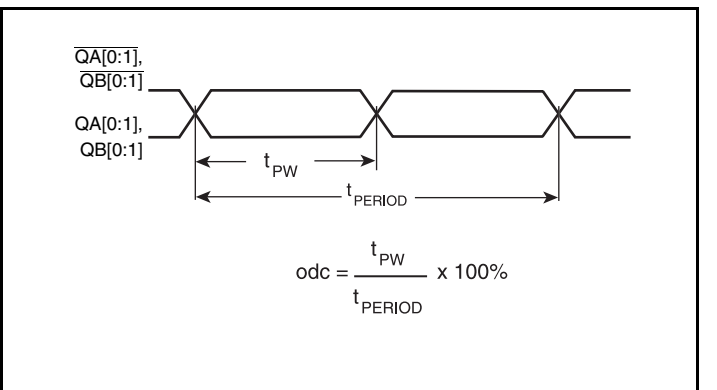

Output Duty Cycle/Pulse Width/Period

## Parameter Measurement Information, continued

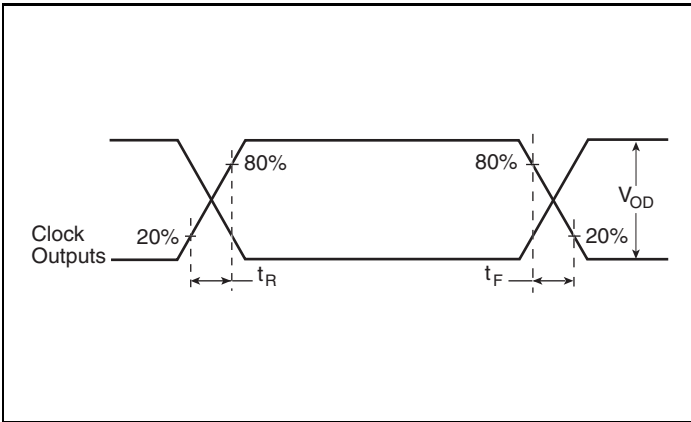

LVDS Output Rise/Fall Time

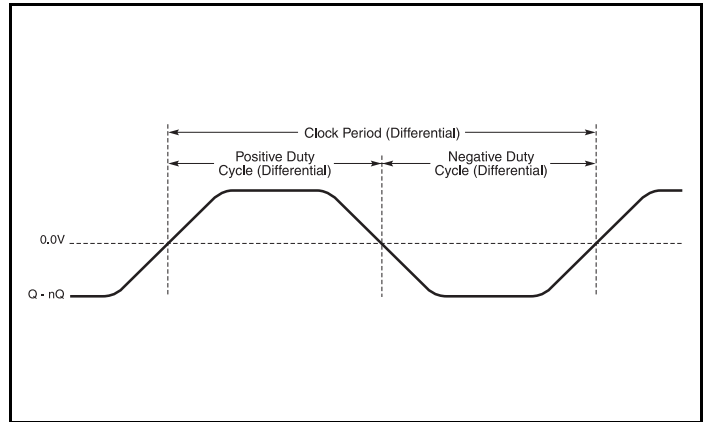

Differential Measurement Points for Duty Cycle/Period

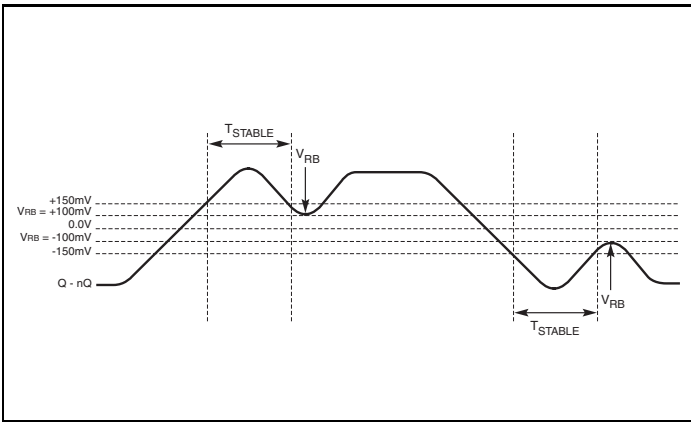

Differential Measurement Points for Ringback

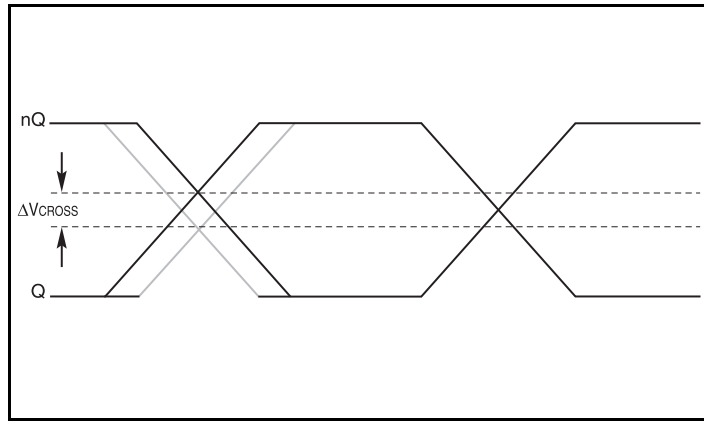

SE Measurement Points for Delta Cross Point

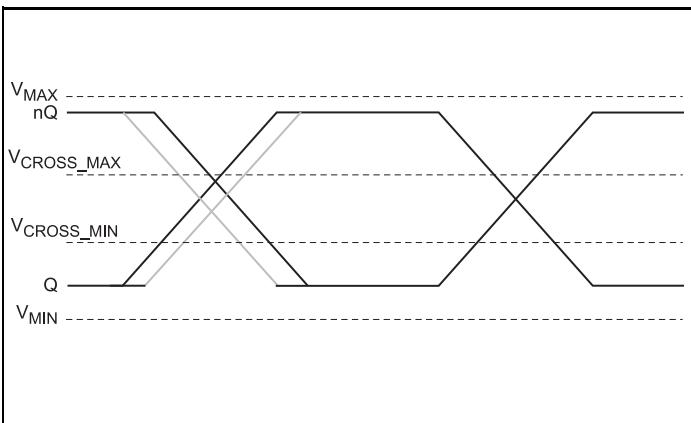

SE Measurement Points for Absolute Cross Point/Swing

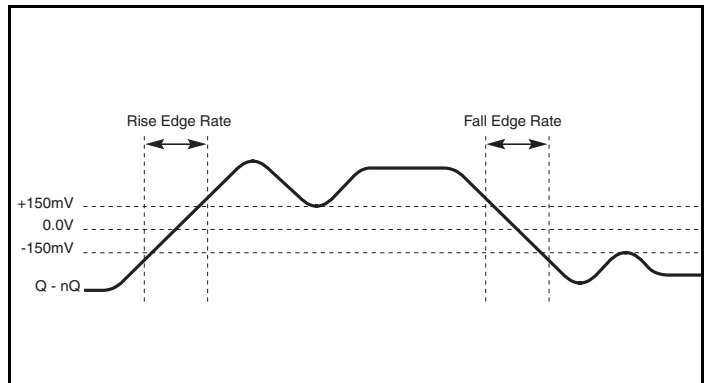

Differential Measurement Points for Rise/Fall Time



## Parameter Measurement Information, continued

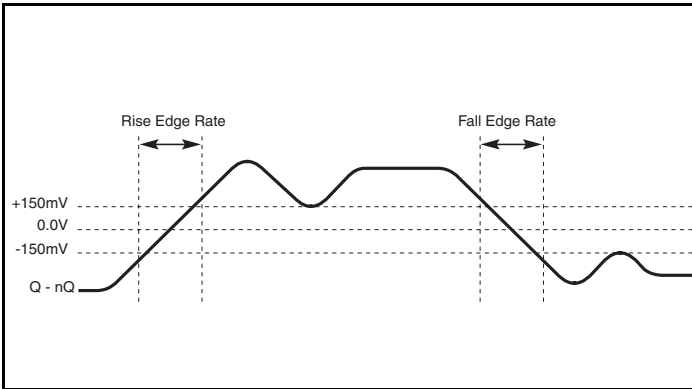

Differential Measurement Points for Rise/Fall Time

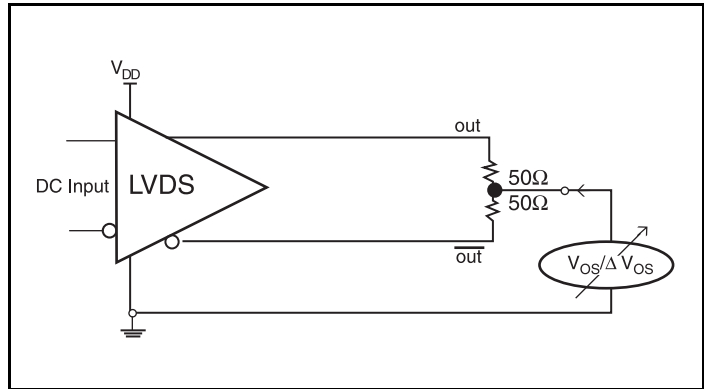

Offset Voltage Setup

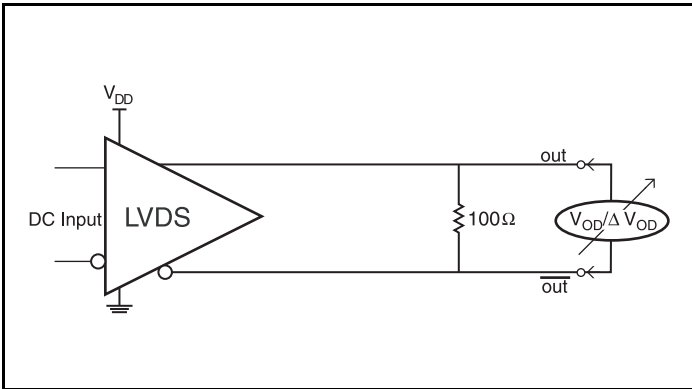

Differential Output Voltage Setup

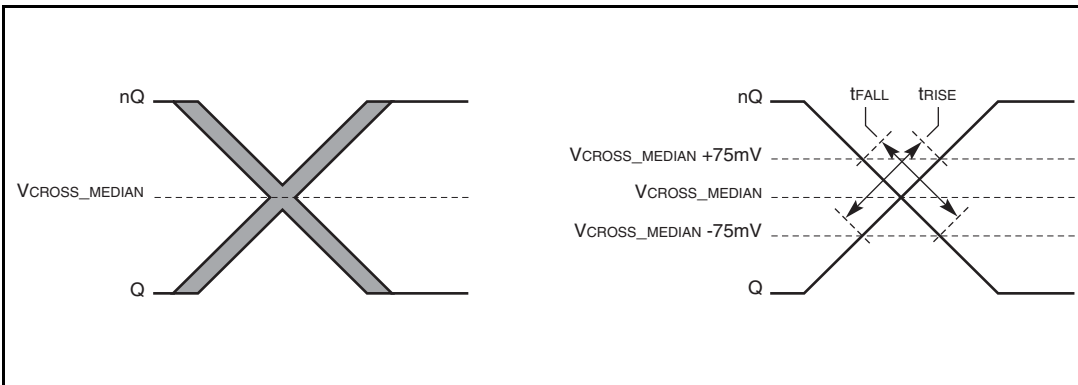

SE Measurement Points for Rise/Fall Time Matching

## Application Information

### Power Supply Filtering Technique

As in any high speed analog circuitry, the power supply pins are vulnerable to random noise. To achieve optimum jitter performance, power supply isolation is required. The 8741004 provides separate power supplies to isolate any high switching noise from the outputs to the internal PLL.  $V_{DD}$ ,  $V_{DDA}$  and  $V_{DDO}$  should be individually connected to the power supply plane through vias, and  $0.01\mu\text{F}$  bypass capacitors should be used for each pin. *Figure 1* illustrates this for a generic  $V_{DD}$  pin and also shows that  $V_{DDA}$  requires that an additional  $10\Omega$  resistor along with a  $10\mu\text{F}$  bypass capacitor be connected to the  $V_{DDA}$  pin.

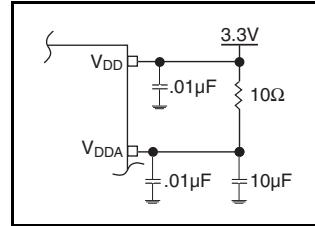

Figure 1. Power Supply Filtering

### Wiring the Differential Input to Accept Single Ended Levels

*Figure 2* shows how the differential input can be wired to accept single ended levels. The reference voltage  $V_{REF} = V_{DD}/2$  is generated by the bias resistors  $R1$ ,  $R2$  and  $C1$ . This bias circuit should be located as close as possible to the input pin. The ratio of

$R1$  and  $R2$  might need to be adjusted to position the  $V_{REF}$  in the center of the input voltage swing. For example, if the input clock swing is only  $2.5\text{V}$  and  $V_{DD} = 3.3\text{V}$ ,  $V_{REF}$  should be  $1.25\text{V}$  and  $R2/R1 = 0.609$ .

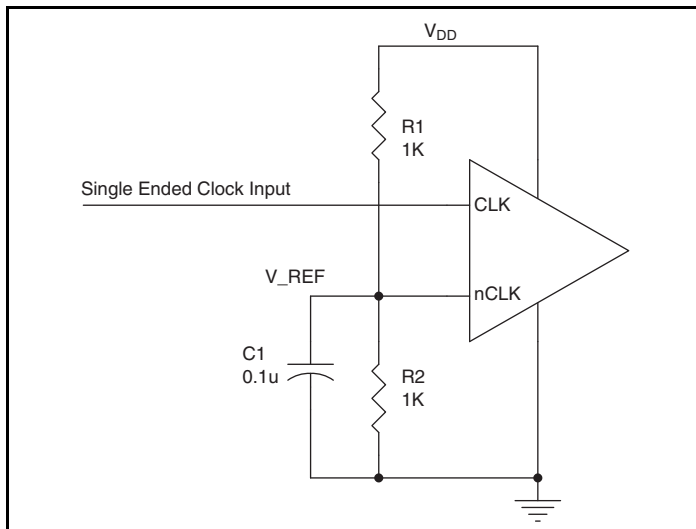
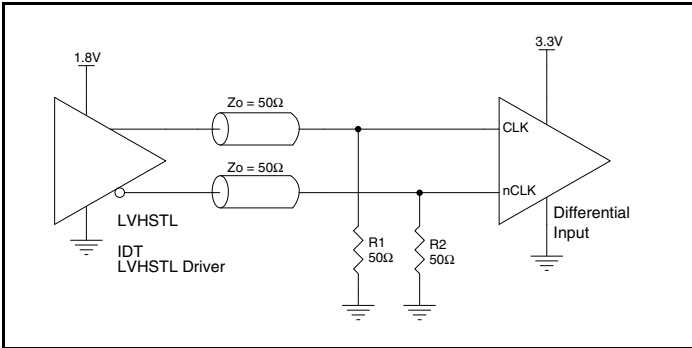

Figure 2. Single-Ended Signal Driving Differential Input

## Differential Clock Input Interface

The CLK /nCLK accepts LVDS, LVPECL, LVHSTL, SSTL, HCSL and other differential signals. Both  $V_{SWING}$  and  $V_{OH}$  must meet the  $V_{PP}$  and  $V_{CMR}$  input requirements. Figures 3A to 3F show interface examples for the HiPerClockS CLK/nCLK input driven by the most common driver types. The input interfaces suggested here are examples only. Please consult with the vendor of the driver

component to confirm the driver termination requirements. For example, in Figure 3A, the input termination applies for IDT HiPerClockS open emitter LVHSTL drivers. If you are using an LVHSTL driver from another vendor, use their termination recommendation.



**Figure 3A. HiPerClockS CLK/nCLK Input Driven by an IDT Open Emitter HiPerClockS LVHSTL Driver**

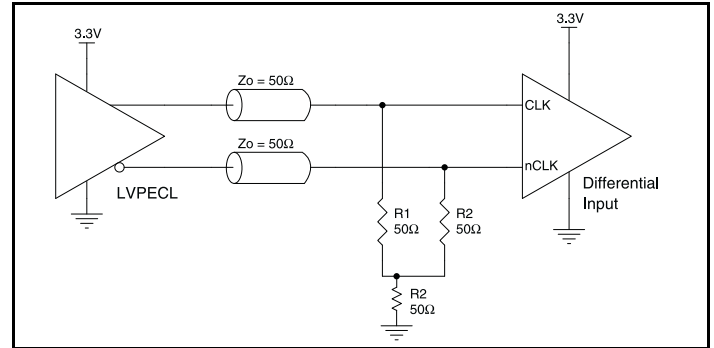

**Figure 3B. HiPerClockS CLK/nCLK Input Driven by a 3.3V LVPECL Driver**

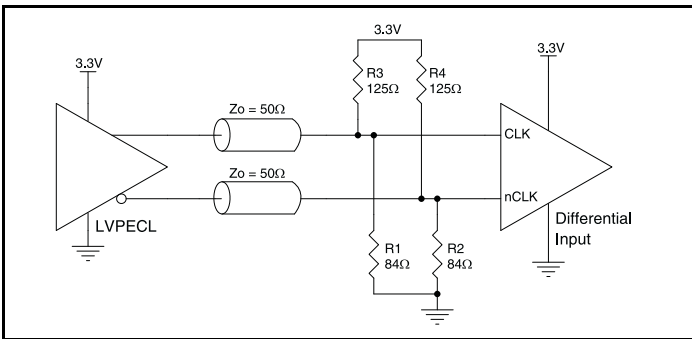

**Figure 3C. HiPerClockS CLK/nCLK Input Driven by a 3.3V LVPECL Driver**

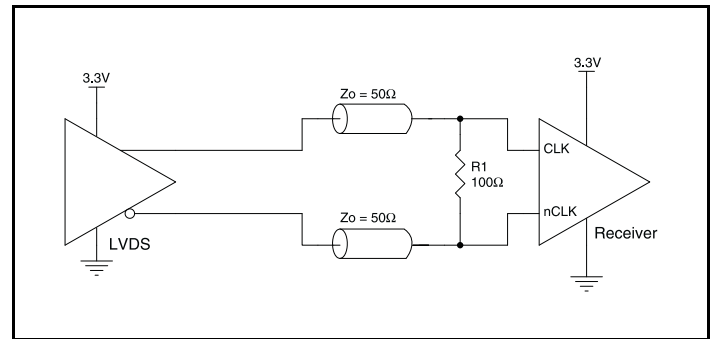

**Figure 3D. HiPerClockS CLK/nCLK Input Driven by a 3.3V LVDS Driver**

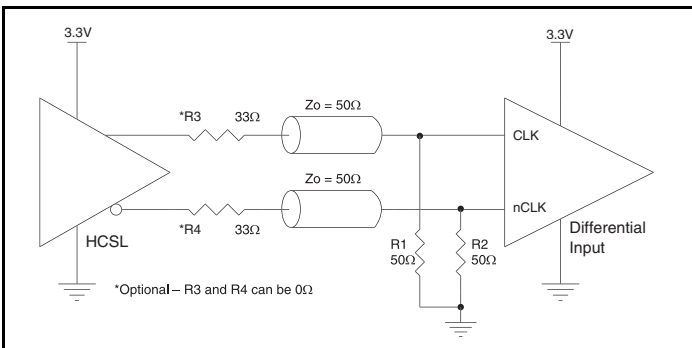

**Figure 3E. HiPerClockS CLK/nCLK Input Driven by a 3.3V HCSL Driver**

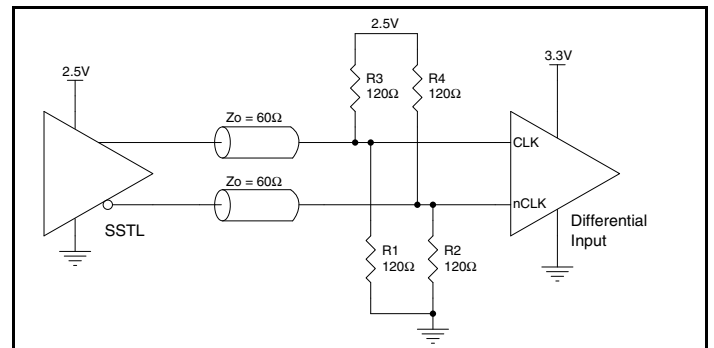

**Figure 3F. HiPerClockS CLK/nCLK Input Driven by a 2.5V SSTL Driver**

## Recommendations for Unused Input and Output Pins

### Inputs:

#### LVC MOS Control Pins

All control pins have internal pull-ups or pull-downs; additional resistance is not required but can be added for additional protection. A 1kΩ resistor can be used.

### Outputs:

#### Differential Outputs

All unused differential outputs can be left floating. We recommend that there is no trace attached. Both sides of the differential output pair should either be left floating or terminated.

#### LVDS Outputs

All unused LVDS output pairs can be either left floating or terminated with 100Ω across. If they are left floating, we recommend that there is no trace attached.

## LVDS Driver Termination

A general LVDS interface is shown in *Figure 4*. In a 100Ω differential transmission line environment, LVDS drivers require a matched load termination of 100Ω across near the receiver input.

For a multiple LVDS outputs buffer, if only partial outputs are used, it is recommended to terminate the unused outputs.

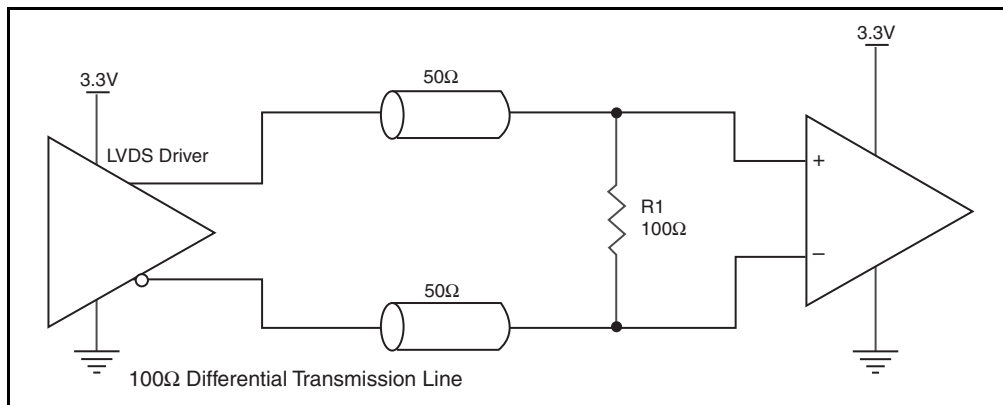

Figure 4. Typical LVDS Driver Termination

### Recommended Termination

Figure 5A is the recommended termination for applications which require the receiver and driver to be on a separate PCB. All traces should be 50Ω impedance.

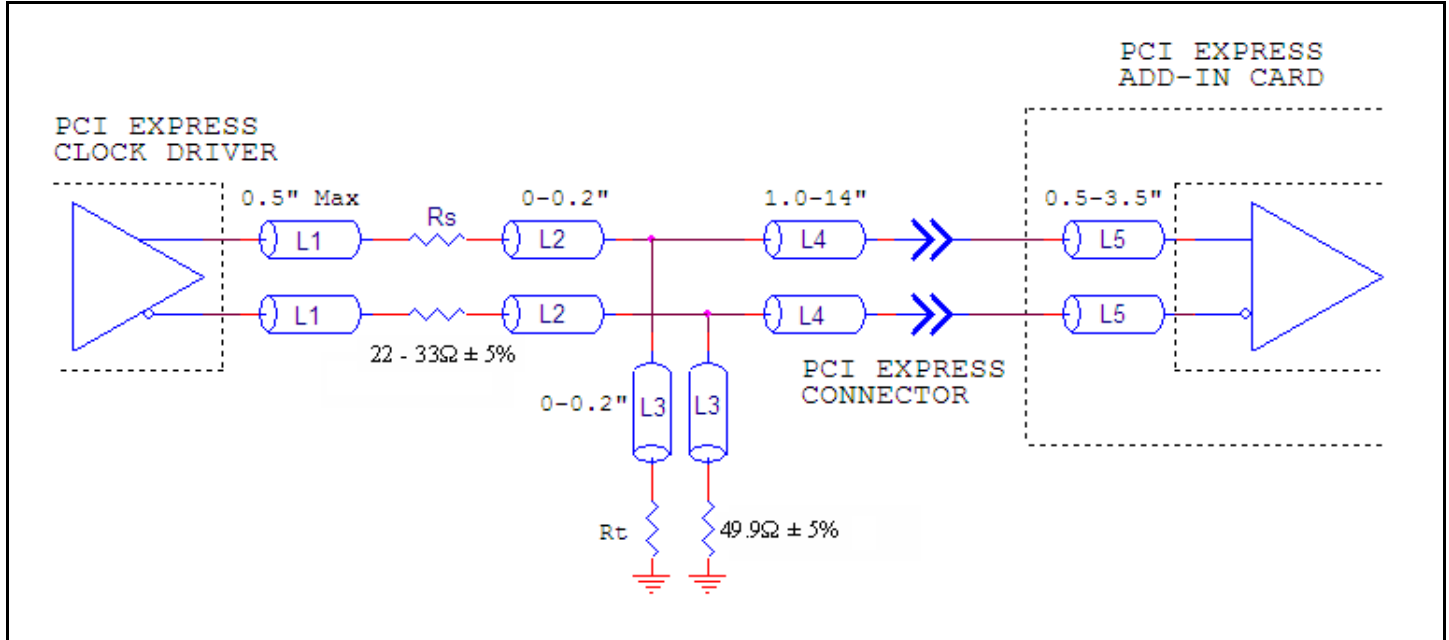

Figure 5A. Recommended Termination

Figure 5B is the recommended termination for applications which require a point to point connection and contain the driver and receiver on the same PCB. All traces should all be 50Ω impedance.

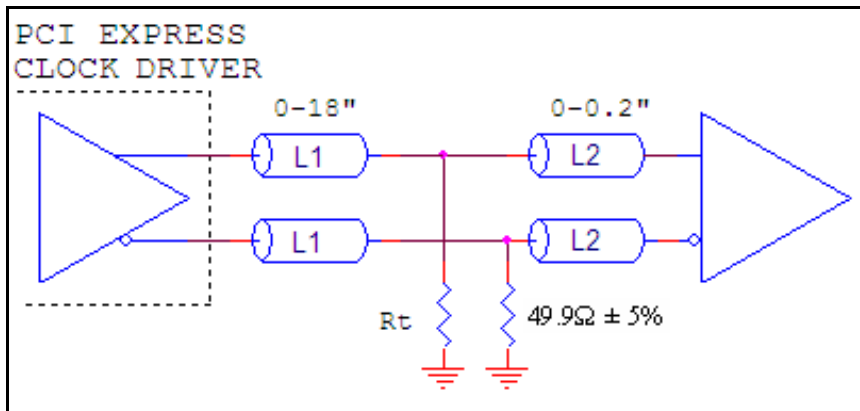

Figure 5B. Recommended Termination

## Power Considerations

This section provides information on power dissipation and junction temperature for the 8741004. Equations and example calculations are also provided.

### 1. Power Dissipation.

The total power dissipation for the ICS741004 is the sum of the core power plus the analog power plus the power dissipated in the load(s). The following is the power dissipation for  $V_{DD} = 3.3V + 5\% = 3.465V$ , which gives worst case results.

NOTE: Please refer to Section 3 for details on calculating power dissipated in the load.

- Power (core)<sub>MAX</sub> =  $V_{DD\_MAX} * (I_{DD\_MAX} + I_{DDA\_MAX}) = 3.465V * (45mA + 12mA) = \mathbf{197.5mW}$
- Power (LVDS\_output)<sub>MAX</sub> =  $V_{DDO\_MAX} * I_{DDO\_MAX} = 3.465V * 80mA = \mathbf{277.2mW}$
- Power (HCSL\_output)<sub>MAX</sub> =  $44.5mW * 2 = \mathbf{89mW}$

**Total Power<sub>MAX</sub>** = (3.465V, with all outputs switching) = 197.5mW + 277.2mW + 89mW = **563.7mW**

### 2. Junction Temperature.

Junction temperature,  $T_j$ , is the temperature at the junction of the bond wire and bond pad and directly affects the reliability of the device. The maximum recommended junction temperature for HiPerClockS devices is 125°C.

The equation for  $T_j$  is as follows:  $T_j = \theta_{JA} * Pd\_total + T_A$

$T_j$  = Junction Temperature

$\theta_{JA}$  = Junction-to-Ambient Thermal Resistance

$Pd\_total$  = Total Device Power Dissipation (example calculation is in section 1 above)

$T_A$  = Ambient Temperature

In order to calculate junction temperature, the appropriate junction-to-ambient thermal resistance  $\theta_{JA}$  must be used. Assuming no air flow and a multi-layer board, the appropriate value is 82.3°C/W per Table 6 below.

Therefore,  $T_j$  for an ambient temperature of 70°C with all outputs switching is:

$$70^\circ\text{C} + 0.564\text{W} * 82.3^\circ\text{C}/\text{W} = 116.4^\circ\text{C}. \text{ This is below the limit of } 125^\circ\text{C}.$$

This calculation is only an example.  $T_j$  will obviously vary depending on the number of loaded outputs, supply voltage, air flow and the type of board (single layer or multi-layer).

**Table 6. Thermal Resistance  $\theta_{JA}$  for 24 Lead TSSOP, Forced Convection**

$\theta_{JA}$ Vs. Air Flow			
Meters per Second	0	1	2.5
Multi-Layer PCB, JEDEC Standard Test Boards	82.3°C/W	78.0°C/W	75.9°C/W

**3. Calculations and Equations.**

The purpose of this section is to calculate power dissipation on the IC per HCSL output pair.

HCSL output driver circuit and termination are shown in *Figure 6*.

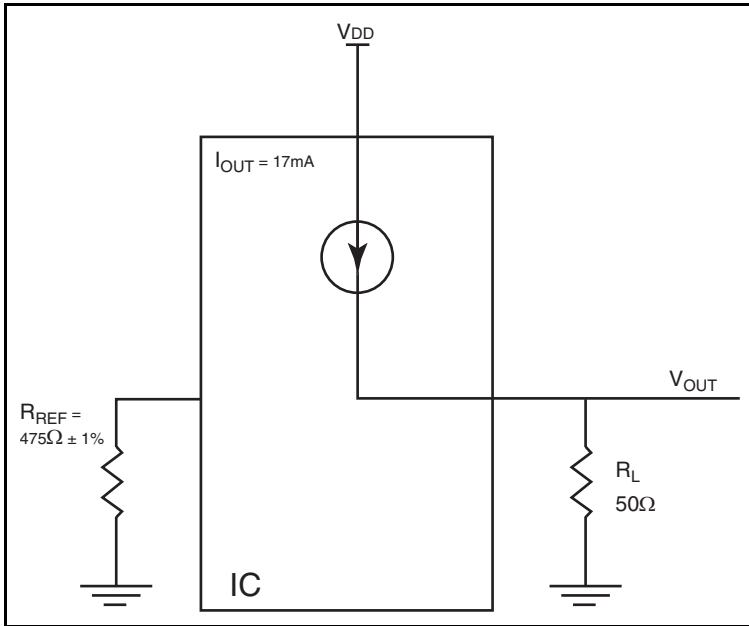

**Figure 6. HCSL Driver Circuit and Termination**

HCSL is a current steering output which sources a maximum of 17mA of current per output. To calculate worst case on-chip power dissipation, use the following equations which assume a 50Ω load to ground.

The highest power dissipation occurs when  $V_{DD\_MAX}$ .

$$\begin{aligned}
 \text{Power} &= (V_{DD\_MAX} - V_{OUT}) * I_{OUT}, \text{ since } V_{OUT} = I_{OUT} * R_L \\
 &= (V_{DD\_MAX} - I_{OUT} * R_L) * I_{OUT} \\
 &= (3.465V - 17mA * 50\Omega) * 17mA
 \end{aligned}$$

Total Power Dissipation per output pair = **44.5mW**

## Reliability Information

Table 7.  $\theta_{JA}$  vs. Air Flow Table for a 24 Lead TSSOP

$\theta_{JA}$ vs. Air Flow			
Meters per Second	0	1	2.5
Multi-Layer PCB, JEDEC Standard Test Boards	82.3°C/W	78.0°C/W	75.9°C/W

## Transistor Count

The transistor count for 8741004 is: 1318

## Package Outline and Package Dimensions

Package Outline - G Suffix for 24 Lead TSSOP

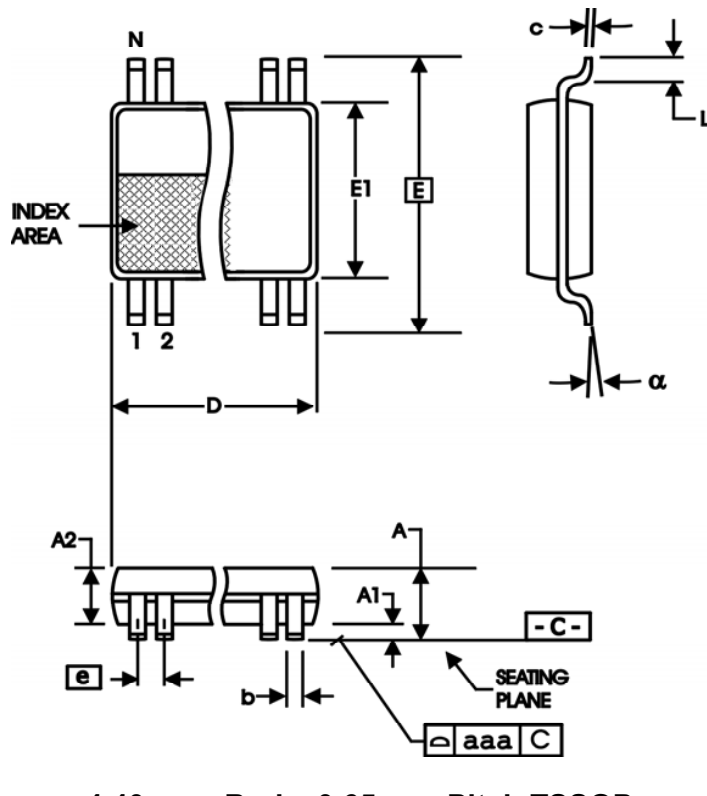

Table 8. Package Dimensions

All Dimensions in Millimeters		
Symbol	Minimum	Maximum
N	24	
A		1.20
A1	0.5	0.15
A2	0.80	1.05
b	0.19	0.30
c	0.09	0.20
D	7.70	7.90
E	6.40 Basic	
E1	4.30	4.50
e	0.65 Basic	
L	0.45	0.75
$\alpha$	0°	8°
aaa		0.10

Reference Document: JEDEC Publication 95, MO-153



## Ordering Information

Table 9. Ordering Information

Part/Order Number	Marking	Package	Shipping Packaging	Temperature
8741004AGLF	ICS8741004AGL	"Lead-Free" 24 Lead TSSOP	Tray	0°C to 70°C
8741004AGLFT	ICS8741004AGL	"Lead-Free" 24 Lead TSSOP	2500 Tape & Reel	0°C to 70°C

NOTE: Parts that are ordered with an "LF" suffix to the part number are the Pb-Free configuration and are RoHS compliant.

## Revision History Sheet

Rev	Table	Page	Description of Change	Date
A	T4C T5	5 6 8 & 9 11	Differential DC Characteristics Table - added NOTE. AC Characteristics Table - corrected $V_{HIGH}/V_{LOW}$ units from ps to mV. Added HCSL Parameter Measurement Information. Updated <i>Differential Clock Input Interface</i> section.	10/31/07
A	T3C	4 14 & 15	Added F_SEL Function Table. Power Considerations - updated Power Dissipation section to coincide with updates to the Calculations & Equations section on page 15.	5/29/08
A	T9	17	Ordering Information - removed leaded devices. Updated data sheet format.	7/20/15



## IMPORTANT NOTICE AND DISCLAIMER

RENESAS ELECTRONICS CORPORATION AND ITS SUBSIDIARIES (“RENESAS”) PROVIDES TECHNICAL SPECIFICATIONS AND RELIABILITY DATA (INCLUDING DATASHEETS), DESIGN RESOURCES (INCLUDING REFERENCE DESIGNS), APPLICATION OR OTHER DESIGN ADVICE, WEB TOOLS, SAFETY INFORMATION, AND OTHER RESOURCES “AS IS” AND WITH ALL FAULTS, AND DISCLAIMS ALL WARRANTIES, EXPRESS OR IMPLIED, INCLUDING, WITHOUT LIMITATION, ANY IMPLIED WARRANTIES OF MERCHANTABILITY, FITNESS FOR A PARTICULAR PURPOSE, OR NON-INFRINGEMENT OF THIRD PARTY INTELLECTUAL PROPERTY RIGHTS.

These resources are intended for developers skilled in the art designing with Renesas products. You are solely responsible for (1) selecting the appropriate products for your application, (2) designing, validating, and testing your application, and (3) ensuring your application meets applicable standards, and any other safety, security, or other requirements. These resources are subject to change without notice. Renesas grants you permission to use these resources only for development of an application that uses Renesas products. Other reproduction or use of these resources is strictly prohibited. No license is granted to any other Renesas intellectual property or to any third party intellectual property. Renesas disclaims responsibility for, and you will fully indemnify Renesas and its representatives against, any claims, damages, costs, losses, or liabilities arising out of your use of these resources. Renesas' products are provided only subject to Renesas' Terms and Conditions of Sale or other applicable terms agreed to in writing. No use of any Renesas resources expands or otherwise alters any applicable warranties or warranty disclaimers for these products.

(Rev.1.0 Mar 2020)

### Corporate Headquarters

TOYOSU FORESIA, 3-2-24 Toyosu,  
Koto-ku, Tokyo 135-0061, Japan  
[www.renesas.com](http://www.renesas.com)

### Contact Information

For further information on a product, technology, the most up-to-date version of a document, or your nearest sales office, please visit:  
[www.renesas.com/contact/](http://www.renesas.com/contact/)

### Trademarks

Renesas and the Renesas logo are trademarks of Renesas Electronics Corporation. All trademarks and registered trademarks are the property of their respective owners.