

November 1997

### Features

- Buffered Inputs
- Separate Serial Outputs Synchronous to Both Positive and Negative Clock Edges For Cascading
- Fanout (Over Temperature Range)
  - Standard Outputs . . . . . 10 LSTTL Loads
  - Bus Driver Outputs . . . . . 15 LSTTL Loads
- Wide Operating Temperature Range . . . -55°C to 125°C
- Balanced Propagation Delay and Transition Times
- Significant Power Reduction Compared to LSTTL Logic ICs
- HC Types
  - 2V to 6V Operation
  - High Noise Immunity:  $N_{IL} = 30\%$ ,  $N_{IH} = 30\%$  of  $V_{CC}$  at  $V_{CC} = 5V$
- HCT Types
  - 4.5V to 5.5V Operation
  - Direct LSTTL Input Logic Compatibility,  $V_{IL} = 0.8V$  (Max),  $V_{IH} = 2V$  (Min)
  - CMOS Input Compatibility,  $I_I \leq 1\mu A$  at  $V_{OL}$ ,  $V_{OH}$

### Description

The Harris CD74HC4094 and CD74HCT4094 are 8-stage serial shift registers having a storage latch associated with each stage for strobing data from the serial input to parallel buffered three-state outputs. The parallel outputs may be connected directly to common bus lines. Data is shifted on positive clock transitions. The data in each shift register stage is transferred to the storage register when the Strobe input is high. Data in the storage register appears at the outputs whenever the Output-Enable signal is high.

Two serial outputs are available for cascading a number of these devices. Data is available at the  $QS_1$  serial output terminal on positive clock edges to allow for high-speed operation in cascaded system in which the clock rise time is fast. The same serial information, available at the  $QS_2$  terminal on the next negative clock edge, provides a means for cascading these devices when the clock rise time is slow.

### Ordering Information

PART NUMBER	TEMP. RANGE (°C)	PACKAGE	PKG. NO.
CD74HC4094E	-55 to 125	16 Ld PDIP	E16.3
CD74HCT4094E	-55 to 125	16 Ld PDIP	E16.3
CD74HC4094M	-55 to 125	16 Ld SOIC	M16.15
CD74HCT4094M	-55 to 125	16 Ld SOIC	M16.15

### Pinout

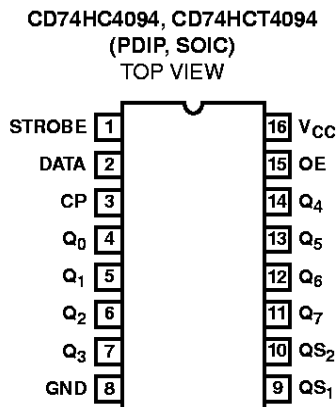

### NOTES:

1. When ordering, use the entire part number. Add the suffix 96 to obtain the variant in the tape and reel.
2. Wafer or die for this part number is available which meets all electrical specifications. Please contact your local sales office or Harris customer service for ordering information.

## CD74HC4094, CD74HCT4094

### Functional Diagram

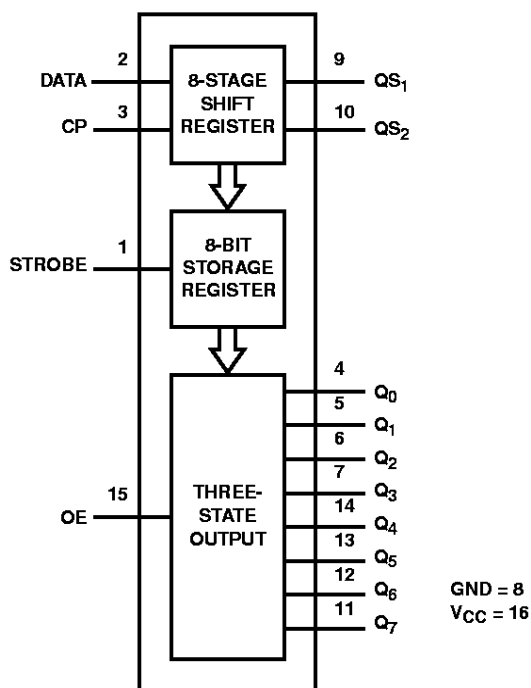

TRUTH TABLE

INPUTS				PARALLEL OUTPUTS		SERIAL OUTPUTS	
CP	OE	STR	D	Q <sub>0</sub>	Q <sub>n</sub>	QS <sub>1</sub> (NOTE 4)	QS <sub>2</sub>
↑	L	X	X	Z	Z	Q <sub>6</sub>	NC
↓	L	X	X	Z	Z	NC	Q <sub>7</sub>
↑	H	L	X	NC	NC	Q <sub>6</sub>	NC
↑	H	H	L	L	Q <sub>n</sub> - 1	Q <sub>6</sub>	NC
↑	H	H	H	H	Q <sub>n</sub> - 1	Q <sub>6</sub>	NC
↓	H	H	H	NC	NC	NC	Q <sub>7</sub>

**NOTES:**

3. H = High Voltage Level, L = Low Voltage Level, X = Don't Care, NC = No charge, Z = High Impedance Off-state,  
 ↑ = Transition from Low to High Level, ↓ = Transition from High to Low.
4. At the positive clock edge the information in the seventh register stage is transferred to the 8th register stage and QS<sub>1</sub> output.



## CD74HC4094, CD74HCT4094

### Absolute Maximum Ratings

DC Supply Voltage, $V_{CC}$ .....	-0.5V to 7V
DC Input Diode Current, $I_{IK}$	
For $V_I < -0.5V$ or $V_I > V_{CC} + 0.5V$ .....	$\pm 20mA$
DC Output Diode Current, $I_{OK}$	
For $V_O < -0.5V$ or $V_O > V_{CC} + 0.5V$ .....	$\pm 20mA$
DC Output Source or Sink Current per Output Pin, $I_O$	
For $V_O > -0.5V$ or $V_O < V_{CC} + 0.5V$ .....	$\pm 25mA$
DC $V_{CC}$ or Ground Current, $I_{CC}$ .....	$\pm 50mA$

### Thermal Information

Thermal Resistance (Typical, Note 5)	$\theta_{JA}$ ( $^{\circ}C/W$ )
PDIP Package .....	90
SOIC Package .....	160
Maximum Junction Temperature .....	$150^{\circ}C$
Maximum Storage Temperature Range .....	$-65^{\circ}C$ to $150^{\circ}C$
Maximum Lead Temperature (Soldering 10s) .....	$300^{\circ}C$ (SOIC - Lead Tips Only)

### Operating Conditions

Temperature Range ( $T_A$ ) .....	$-55^{\circ}C$ to $125^{\circ}C$
Supply Voltage Range, $V_{CC}$	
HC Types .....	2V to 6V
HCT Types .....	4.5V to 5.5V
DC Input or Output Voltage, $V_I, V_O$ .....	0V to $V_{CC}$
Input Rise and Fall Time	
2V .....	1000ns (Max)
4.5V .....	500ns (Max)
6V .....	400ns (Max)

*CAUTION: Stresses above those listed in "Absolute Maximum Ratings" may cause permanent damage to the device. This is a stress only rating and operation of the device at these or any other conditions above those indicated in the operational sections of this specification is not implied.*

#### NOTE:

5.  $\theta_{JA}$  is measured with the component mounted on an evaluation PC board in free air.

### DC Electrical Specifications

PARAMETER	SYMBOL	TEST CONDITIONS		$V_{CC}$ (V)	25 $^{\circ}C$			-40 $^{\circ}C$ TO 85 $^{\circ}C$		-55 $^{\circ}C$ TO 125 $^{\circ}C$		UNITS
		$V_I$ (V)	$I_O$ (mA)		MIN	TYP	MAX	MIN	MAX	MIN	MAX	
<b>HC TYPES</b>												
High Level Input Voltage	$V_{IH}$	-	-	2	1.5	-	-	1.5	-	1.5	-	V
				4.5	3.15	-	-	3.15	-	3.15	-	V
				6	4.2	-	-	4.2	-	4.2	-	V
Low Level Input Voltage	$V_{IL}$	-	-	2	-	-	0.5	-	0.5	-	0.5	V
				4.5	-	-	1.35	-	1.35	-	1.35	V
				6	-	-	1.8	-	1.8	-	1.8	V
High Level Output Voltage CMOS Loads	$V_{OH}$	$V_{IH}$ or $V_{IL}$	-0.02	2	1.9	-	-	1.9	-	1.9	-	V
			-0.02	4.5	4.4	-	-	4.4	-	4.4	-	V
			-0.02	6	5.9	-	-	5.9	-	5.9	-	V
High Level Output Voltage TTL Loads	$V_{OH}$	$V_{IH}$ or $V_{IL}$	-	-	-	-	-	-	-	-	-	V
			-4	4.5	3.98	-	-	3.84	-	3.7	-	V
			-5.2	6	5.48	-	-	5.34	-	5.2	-	V
Low Level Output Voltage CMOS Loads	$V_{OL}$	$V_{IH}$ or $V_{IL}$	0.02	2	-	-	0.1	-	0.1	-	0.1	V
			0.02	4.5	-	-	0.1	-	0.1	-	0.1	V
			0.02	6	-	-	0.1	-	0.1	-	0.1	V
Low Level Output Voltage TTL Loads	$V_{OL}$	$V_{IH}$ or $V_{IL}$	-	-	-	-	-	-	-	-	-	V
			4	4.5	-	-	0.26	-	0.33	-	0.4	V
			5.2	6	-	-	0.26	-	0.33	-	0.4	V
Input Leakage Current	$I_I$	$V_{CC}$ or GND	-	6	-	-	$\pm 0.1$	-	$\pm 1$	-	$\pm 1$	$\mu A$
Quiescent Device Current	$I_{CC}$	$V_{CC}$ or GND	0	6	-	-	8	-	80	-	160	$\mu A$

## CD74HC4094, CD74HCT4094

### DC Electrical Specifications (Continued)

PARAMETER	SYMBOL	TEST CONDITIONS		V <sub>CC</sub> (V)	25°C			-40°C TO 85°C		-55°C TO 125°C		UNITS
		V <sub>I</sub> (V)	I <sub>O</sub> (mA)		MIN	TYP	MAX	MIN	MAX	MIN	MAX	
<b>HCT TYPES</b>												
High Level Input Voltage	V <sub>IH</sub>	-	-	4.5 to 5.5	2	-	-	2	-	2	-	V
Low Level Input Voltage	V <sub>IL</sub>	-	-	4.5 to 5.5	-	-	0.8	-	0.8	-	0.8	V
High Level Output Voltage CMOS Loads	V <sub>OH</sub>	V <sub>IH</sub> or V <sub>IL</sub>	-0.02	4.5	4.4	-	-	4.4	-	4.4	-	V
High Level Output Voltage TTL Loads			-4	4.5	3.98	-	-	3.84	-	3.7	-	V
Low Level Output Voltage CMOS Loads	V <sub>OL</sub>	V <sub>IH</sub> or V <sub>IL</sub>	0.02	4.5	-	-	0.1	-	0.1	-	0.1	V
Low Level Output Voltage TTL Loads			4	4.5	-	-	0.26	-	0.33	-	0.4	V
Input Leakage Current	I <sub>I</sub>	V <sub>CC</sub> and GND	0	5.5	-	-	±0.1	-	±1	-	±1	μA
Quiescent Device Current	I <sub>CC</sub>	V <sub>CC</sub> or GND	0	5.5	-	-	8	-	80	-	160	μA
Additional Quiescent Device Current Per Input Pin: 1 Unit Load	ΔI <sub>CC</sub> (Note)	V <sub>CC</sub> -2.1	-	4.5 to 5.5	-	100	360	-	450	-	490	μA

NOTE: For dual-supply systems theoretical worst case (V<sub>I</sub> = 2.4V, V<sub>CC</sub> = 5.5V) specification is 1.8mA.

### HCT Input Loading Table

INPUT	UNIT LOADS
D	0.4
CP, OE	1.5
STR	1.0

NOTE: Unit Load is ΔI<sub>CC</sub> limit specified in DC Electrical Table, e.g., 360μA max at 25°C.

### Prerequisite for Switching Specifications

CHARACTERISTIC	SYMBOL	V <sub>CC</sub> (V)	25°C		-40°C TO 85°C		-55°C TO 125°C		UNITS
			MIN	MAX	MIN	MAX	MIN	MAX	
<b>HC TYPES</b>									
CP Pulse Width	t <sub>w</sub>	2	80	-	100	-	120	-	ns
		4.5	16	-	20	-	24	-	ns
		6	14	-	17	-	20	-	ns
STR Pulse Width	t <sub>WH</sub>	2	80	-	100	-	120	-	ns
		4.5	16	-	20	-	24	-	ns
		6	14	-	17	-	20	-	ns

## CD74HC4094, CD74HCT4094

### Prerequisite for Switching Specifications (Continued)

CHARACTERISTIC	SYMBOL	V <sub>CC</sub> (V)	25°C		-40°C TO 85°C		-55°C TO 125°C		UNITS
			MIN	MAX	MIN	MAX	MIN	MAX	
Data Set-up Time	t <sub>SU</sub>	2	50	-	65	-	75	-	ns
		4.5	10	-	13	-	15	-	ns
		6	9	-	11	-	13	-	ns
Data Hold Time	t <sub>H</sub>	2	3	-	3	-	3	-	ns
		4.5	3	-	3	-	3	-	ns
		6	3	-	3	-	3	-	ns
STR Set-up Time	t <sub>SU</sub>	2	100	-	125	-	150	-	ns
		4.5	20	-	25	-	30	-	ns
		6	17	-	21	-	26	-	ns
STR Hold Time	t <sub>H</sub>	2	0	-	0	-	0	-	ns
		4.5	0	-	0	-	0	-	ns
		6	0	-	0	-	0	-	ns
Maximum CP Frequency	f <sub>CL</sub> (MAX)	2	6	-	5	-	4	-	MHz
		4.5	30	-	24	-	20	-	MHz
		6	35	-	28	-	24	-	MHz

#### HCT TYPES

CP Pulse Width	t <sub>W</sub>	4.5	16	-	20	-	24	-	ns
STR Pulse Width	t <sub>WH</sub>	4.5	16	-	20	-	24	-	ns
Data Set-up Time	t <sub>SU</sub>	4.5	10	-	13	-	15	-	ns
Data Hold Time	t <sub>H</sub>	4.5	4	-	4	-	4	-	ns
STR Set-up Time	t <sub>SU</sub>	4.5	20	-	25	-	30	-	ns
STR Hold Time	t <sub>H</sub>	4.5	0	-	0	-	0	-	ns
Maximum CP Frequency	f <sub>CL</sub> (MAX)	4.5	30	-	24	-	20	-	MHz

### Switching Specifications Input t<sub>r</sub>, t<sub>f</sub> = 6ns

PARAMETER	SYMBOL	TEST CONDITIONS	V <sub>CC</sub> (V)	25°C			-40°C TO 85°C		-55°C TO 125°C		UNITS
				MIN	TYP	MAX	MIN	MAX	MIN	MAX	
<b>HC TYPES</b>											
Propagation Delay Time (Figure 1) CP to QS <sub>1</sub>	t <sub>PLH</sub> , t <sub>PHL</sub>	C <sub>L</sub> = 50pF	2	-	-	150	-	190	-	225	ns
			4.5	-	-	30	-	38	-	45	ns
		C <sub>L</sub> = 15pF	5	-	12	-	-	-	-	-	ns
			6	-	-	26	-	33	-	38	ns
CP to QS <sub>2</sub>	t <sub>PLH</sub> , t <sub>PHL</sub>	C <sub>L</sub> = 50pF	2	-	-	135	-	170	-	205	ns
			4.5	-	-	27	-	34	-	41	ns
		C <sub>L</sub> = 15pF	5	-	11	-	-	-	-	-	ns
			6	-	-	23	-	29	-	35	ns
CP to Q <sub>n</sub>	t <sub>PLH</sub> , t <sub>PHL</sub>	C <sub>L</sub> = 50pF	2	-	-	195	-	245	-	295	ns
			4.5	-	-	39	-	49	-	59	ns
			5	-	16	-	-	-	-	-	ns
			6	-	-	33	-	42	-	50	ns
STR to Q <sub>n</sub>	t <sub>PLH</sub> , t <sub>PHL</sub>	C <sub>L</sub> = 50pF	2	-	-	180	-	225	-	270	ns
			4.5	-	-	36	-	45	-	54	ns
			6	-	-	31	-	38	-	46	ns

## CD74HC4094, CD74HCT4094

### Switching Specifications Input $t_r, t_f = 6\text{ns}$ (Continued)

PARAMETER	SYMBOL	TEST CONDITIONS	V <sub>CC</sub> (V)	25°C			-40°C TO 85°C		-55°C TO 125°C		UNITS
				MIN	TYP	MAX	MIN	MAX	MIN	MAX	
Output Enable to Q <sub>n</sub>	t <sub>PZH</sub> , t <sub>PZL</sub>	C <sub>L</sub> = 50pF	2	-	-	175	-	220	-	265	ns
			4.5	-	-	35	-	44	-	53	ns
			6	-	-	30	-	37	-	45	ns
Output Disable to Q <sub>n</sub>	t <sub>PHZ</sub> , t <sub>PLZ</sub>	C <sub>L</sub> = 50pF	2	-	-	125	-	155	-	190	ns
			4.5	-	-	25	-	31	-	38	ns
			6	-	-	21	-	26	-	32	ns
Output Transition Time	t <sub>TLH</sub> , t <sub>THL</sub>	C <sub>L</sub> = 50pF	2	-	-	75	-	95	-	110	ns
			4.5	-	-	15	-	19	-	22	ns
			6	-	-	13	-	16	-	19	ns
Output Disabling Time	t <sub>PHZ</sub> , t <sub>PLZ</sub>	C <sub>L</sub> = 15pF	5	-	10	-	-	-	-	ns	
Maximum CP Frequency	f <sub>MAX</sub>	C <sub>L</sub> = 15pF	5	-	60	-	-	-	-	MHz	
Input Capacitance	C <sub>IN</sub>	C <sub>L</sub> = 50pF	-	-	-	10	-	10	-	10	pF
Power Dissipation Capacitance (Notes 6, 7)	C <sub>PD</sub>	C <sub>L</sub> = 15pF	5	-	90	-	-	-	-	-	pF
Three-State Output Capacitance	C <sub>O</sub>	C <sub>L</sub> = 50pF	-	-	-	15	-	15	-	15	pF
<b>HCT TYPES</b>											
Propagation Delay Time (Figure 1)	t <sub>PLH</sub> , t <sub>PHL</sub>	C <sub>L</sub> = 50pF	4.5	-	-	39	-	-	-	-	ns
		C <sub>L</sub> = 15pF	5	-	16	-	-	-	-	-	ns
CP to QS <sub>1</sub>	t <sub>PLH</sub> , t <sub>PHL</sub>	C <sub>L</sub> = 50pF	4.5	-	-	36	-	-	-	-	ns
CP to QS <sub>2</sub>		C <sub>L</sub> = 15pF	5	-	15	-	-	-	-	-	ns
CP to Q <sub>n</sub>	t <sub>PLH</sub> , t <sub>PHL</sub>	C <sub>L</sub> = 50pF	4.5	-	-	43	-	-	-	-	ns
		C <sub>L</sub> = 15pF	5	-	18	-	-	-	-	-	ns
STR to Q <sub>n</sub>	t <sub>PLH</sub> , t <sub>PHL</sub>	C <sub>L</sub> = 50pF	4.5	-	-	39	-	-	-	-	ns
Output Enable to Q <sub>n</sub>	t <sub>PZH</sub> , t <sub>PZL</sub>	C <sub>L</sub> = 50pF	4.5	-	-	35	-	-	-	-	ns
Output Disable to Q <sub>n</sub>	t <sub>PHZ</sub> , t <sub>PLZ</sub>	C <sub>L</sub> = 50pF	4.5	-	-	35	-	-	-	-	ns
Output Transition Time	t <sub>TLH</sub> , t <sub>THL</sub>	C <sub>L</sub> = 50pF	4.5	-	-	15	-	-	-	-	ns
Output Disabling Time	t <sub>PHZ</sub> , t <sub>PLZ</sub>	C <sub>L</sub> = 15pF	5	-	14	-	-	-	-	-	ns
Maximum CP Frequency	f <sub>MAX</sub>	C <sub>L</sub> = 15pF	5	-	60	-	-	-	-	-	MHz
Input Capacitance	C <sub>IN</sub>	C <sub>L</sub> = 50pF	-	-	-	10	-	10	-	10	pF
Power Dissipation Capacitance (Notes 6, 7)	C <sub>PD</sub>	C <sub>L</sub> = 15pF	5	-	110	-	-	-	-	-	pF
Three-State Output Capacitance	C <sub>O</sub>	C <sub>L</sub> = 50pF	-	-	-	15	-	15	-	15	pF

**NOTES:**

6. C<sub>PD</sub> is used to determine the dynamic power consumption, per register.

7.  $P_D = V_{CC}^2 f_i (C_{PD} + C_L)$  where  $f_i$  = Input Frequency,  $C_L$  = Output Load Capacitance,  $V_{CC}$  = Supply Voltage.

**Test Circuits and Waveforms**

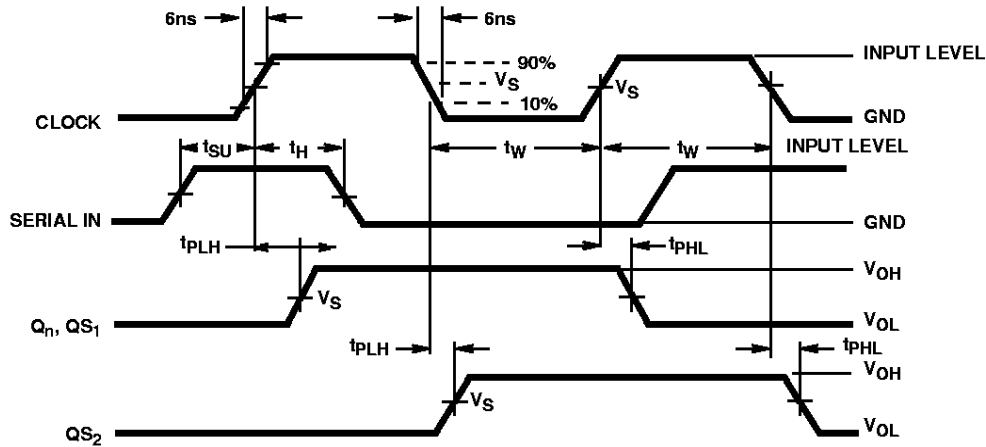

FIGURE 1. DATA PROPAGATION DELAYS, SET-UP AND HOLD TIMES

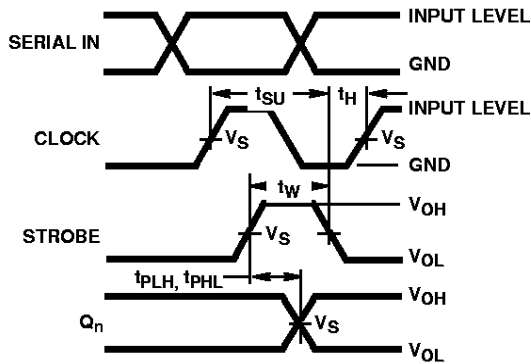

FIGURE 2. STROBE PROPAGATION DELAYS AND SET-UP AND HOLD TIMES

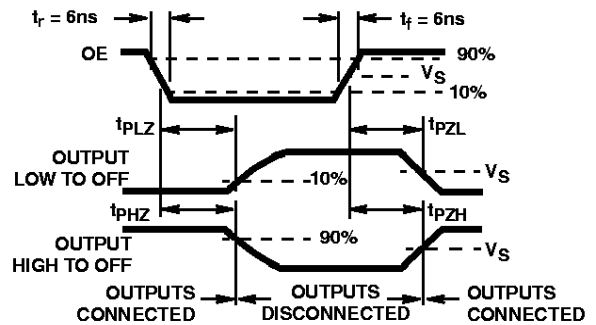

FIGURE 3. ENABLE AND DISABLE TIMES

All Harris Semiconductor products are manufactured, assembled and tested under **ISO9000** quality systems certification.

*Harris Semiconductor products are sold by description only. Harris Semiconductor reserves the right to make changes in circuit design and/or specifications at any time without notice. Accordingly, the reader is cautioned to verify that data sheets are current before placing orders. Information furnished by Harris is believed to be accurate and reliable. However, no responsibility is assumed by Harris or its subsidiaries for its use; nor for any infringements of patents or other rights of third parties which may result from its use. No license is granted by implication or otherwise under any patent or patent rights of Harris or its subsidiaries.*

**Sales Office Headquarters**

For general information regarding Harris Semiconductor and its products, call **1-800-4-HARRIS**

**NORTH AMERICA**  
 Harris Semiconductor  
 P. O. Box 883, Mail Stop 53-210  
 Melbourne, FL 32902  
 TEL: 1-800-442-7747  
 (407) 729-4984  
 FAX: (407) 729-5321

**EUROPE**  
 Harris Semiconductor  
 Mercure Center  
 100, Rue de la Fusée  
 1130 Brussels, Belgium  
 TEL: (32) 2.724.2111  
 FAX: (32) 2.724.22.05

**ASIA**  
 Harris Semiconductor PTE Ltd.  
 No. 1 Tannery Road  
 Cencon 1, #09-01  
 Singapore 1334  
 TEL: (65) 748-4200  
 FAX: (65) 748-0400

