

## SMPTE 292M / 259M Serial Digital Cable Driver

### General Description

The CLC002 SMPTE 292M / 259M serial digital cable driver is a monolithic, high-speed cable driver designed for use in SMPTE 292M / 259M serial digital video and ITU-T G.703 serial digital data transmission applications. The CLC002 drives 75Ω transmission lines (Belden 8281, Belden 1694A or equivalent) at data rates up to 1.485 Gbps.

The CLC002 provides two selectable slew rates for SMPTE 259M and SMPTE 292M compliance. The output voltage swing is adjustable via a single external resistor.

The CLC002 is powered from a single 3.3V supply. Power consumption is typically 125mW in SD mode and 149mW in HD mode.

### Features

- SMPTE 292M, SMPTE 344M and SMPTE 259M compliant
- Data rates to 1.485 Gbps
- Differential input
- 75Ω differential output
- Selectable slew rate
- Adjustable output amplitude
- Single 3.3V supply operation
- Operating temperature range: Commercial 0°C to +70°C (CLC002MA) or Industrial -40°C to +85°C (CLC002TMA)
- Typical power consumption: 125mW in SD mode and 149mW in HD mode
- Replaces the GS1528 and GS1528A

### Applications

- SMPTE 292M, SMPTE 344M, and SMPTE 259M serial digital interfaces
- Sonet/SDH and ATM interfaces
- Digital routers and switches
- Distribution amplifiers
- Buffer applications
- Set top boxes
- Security cameras

### Typical Application

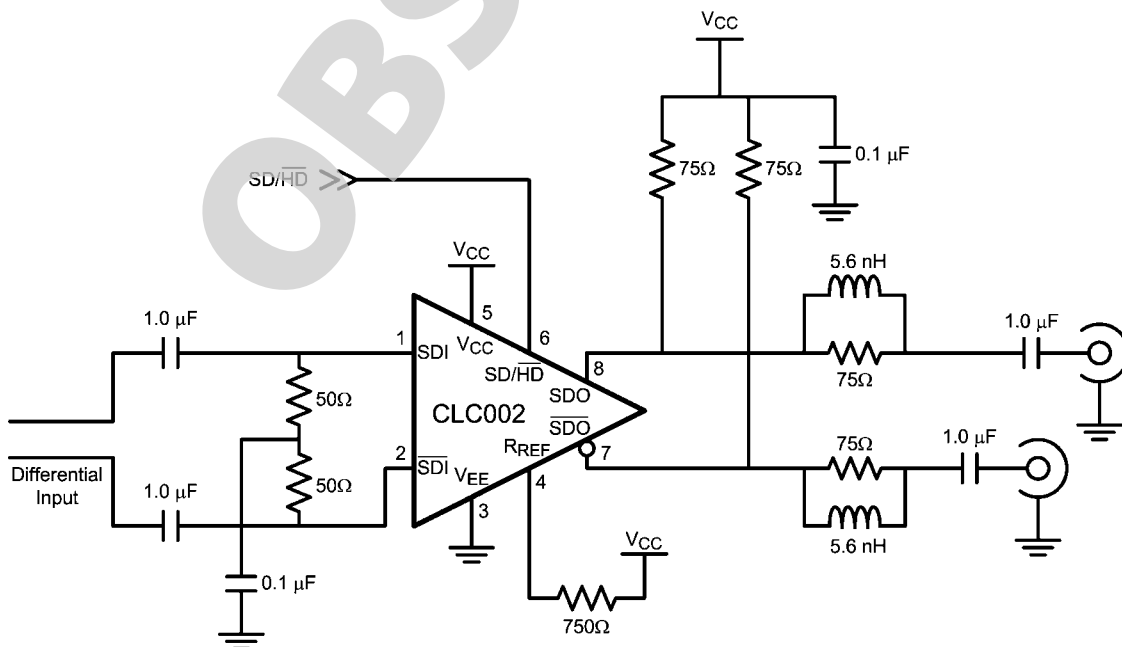

20087602

**Absolute Maximum Ratings** (Note 1)

Supply Voltage:	-0.5V to 3.6V
Input Voltage (all inputs)	-0.3V to $V_{CC}+0.3V$
Output Current	28mA
Storage Temperature Range	-65°C to +150°C
Junction Temperature	+150°C
Lead Temperature (Soldering 4 Sec)	+260°C
Package Thermal Resistance	
$\theta_{JA}$ 8-pin SOIC	+125°C/W
$\theta_{JC}$ 8-pin SOIC	+105°C/W

ESD Rating (HBM)

5kV

ESD Rating (MM)

250V

**Recommended Operating Conditions**

Supply Voltage ( $V_{CC} - V_{EE}$ ):	3.3V $\pm$ 5%
Operating Free Air Temperature ( $T_A$ )	
CLC002MA	0°C to +70°C
CLC002TMA	-40°C to +85°C

**DC Electrical Characteristics**

Over Supply Voltage and Operating Temperature ranges, unless otherwise specified (Note 2, Note 3).

Symbol	Parameter	Conditions	Reference	Min	Typ	Max	Units
$V_{CMIN}$	Input Common Mode Voltage		SDI, $\overline{SDI}$	1.6 + $V_{SDI}/2$		$V_{CC} -$ $V_{SDI}/2$	V
$V_{SDI}$	Input Voltage Swing	Differential		100		2000	mV <sub>P-P</sub>
$V_{CMOUT}$	Output Common Mode Voltage		SDO, $\overline{SDO}$		$V_{CC} -$ $V_{SDO}$		V
$V_{SDO}$	Output Voltage Swing	Single-ended, 75 $\Omega$ load, $R_{REF} =$ 750 $\Omega$ 1%		750	800	850	mV <sub>P-P</sub>
		Single-ended, 75 $\Omega$ load, $R_{REF} =$ 590 $\Omega$ 1%		900	1000	1100	mV <sub>P-P</sub>
	SD/ $\overline{HD}$ Input Voltage	Min for SD	SD/ $\overline{HD}$	2.4			V
		Max for HD				0.8	V
	SD/ $\overline{HD}$ Input Current				3.7		$\mu$ A
$I_{CC}$	Supply Current	SD/ $\overline{HD} = 0$ , (Note 5)			45	49	mA
		SD/ $\overline{HD} = 1$ , (Note 5)			38	43	mA

**AC Electrical Characteristics**

Over Supply Voltage and Operating Temperature ranges, unless otherwise specified (Note 3).

Symbol	Parameter	Conditions	Reference	Min	Typ	Max	Units
$DR_{SDI}$	Input Data Rate	(Note 4)	SDI, $\overline{SDI}$			1485	Mbps
$t_{jit}$	Additive Jitter	1.485 Gbps	SDO, $\overline{SDO}$		26		ps <sub>P-P</sub>
		270 Mbps			18		ps <sub>P-P</sub>
$t_r, t_f$	Output Rise Time, Fall Time	SD/ $\overline{HD} = 0$ , 20% – 80%, (Note 6)			120	220	ps
		SD/ $\overline{HD} = 1$ , 20% – 80%		400	560	800	ps
	Mismatch in Rise/Fall Time	(Note 4)				30	ps
$t_{OS}$	Output Overshoot	(Note 4)				8	%
$RL_{SDO}$	Output Return Loss	(Note 7)		15	20		dB

**Note 1:** "Absolute Maximum Ratings" are those parameter values beyond which the life and operation of the device cannot be guaranteed. The stating herein of these maximums shall not be construed to imply that the device can or should be operated at or beyond these values. The table of "Electrical Characteristics" specifies acceptable device operating conditions.

**Note 2:** Current flow into device pins is defined as positive. Current flow out of device pins is defined as negative. All voltages are stated referenced to  $V_{EE} = 0$  Volts.

**Note 3:** Typical values are stated for  $V_{CC} = +3.3V$  and  $T_A = +25^\circ C$ .

**Note 4:** Specification is guaranteed by characterization.

**Note 5:** Maximum  $I_{CC}$  is measured at  $V_{CC} = +3.465V$  and  $T_A = +70^\circ C$ .

**Note 6:** Specification is guaranteed by characterization and verified by test.

**Note 7:** Output return loss is dependent on board design. The CLC002 meets this specification on the SD002 evaluation board from 5MHz to 1.5GHz.

## Connection Diagram

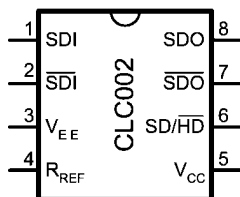

20087601

### 8-Pin SOIC

Order Number CLC002MA or CLC002TMA  
See NS Package Number M08A

## Pin Descriptions

Pin #	Name	Description
1	SDI	Serial data true input.
2	$\overline{\text{SDI}}$	Serial data complement input.
3	$V_{EE}$	Negative power supply (ground).
4	$R_{REF}$	Output driver level control. Connect a resistor to $V_{CC}$ to set output voltage swing.
5	$V_{CC}$	Positive power supply (+3.3V).
6	SD/HD	Output slew rate control. Output rise/fall time complies with SMPTE 292M when low and SMPTE 259M when high.
7	$\overline{\text{SDO}}$	Serial data complement output.
8	SDO	Serial data true output.

## Device Operation

### INPUT INTERFACING

The CLC002 accepts either differential or single-ended input. The inputs are self-biased, allowing for simple AC or DC coupling. DC-coupled inputs must be kept within the specified common-mode range. SDI and  $\overline{\text{SDI}}$  are self-biased at approximately 2.1V with  $V_{CC} = 3.3V$ . Figure 1 shows the differential input stage for SDI and  $\overline{\text{SDI}}$ .

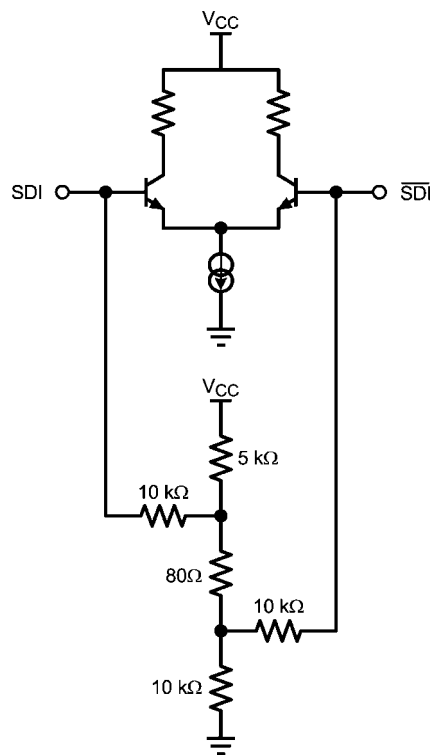

20087604

FIGURE 1. Differential Input Stage for SDI and  $\overline{\text{SDI}}$ .

### OUTPUT INTERFACING

The CLC002 uses current mode outputs. Single-ended output levels are 800 mV<sub>P-P</sub> into 75Ω AC-coupled coaxial cable (with  $R_{REF} = 750\Omega$ ). Output level is controlled by the value of the  $R_{REF}$  resistor connected between pin 4 and  $V_{CC}$ .

The  $R_{REF}$  resistor should be placed as close as possible to the  $R_{REF}$  pin. In addition, the copper in the plane layers below the  $R_{REF}$  network should be removed to minimize parasitic capacitance.

### OUTPUT SLEW RATE CONTROL

The CLC002 output rise and fall times are selectable for either SMPTE 259M or SMPTE 292M compliance via pin 6, SD/ $\overline{HD}$ . For slower rise and fall times, or SMPTE 259M compliance, SD/HD is set high. For faster rise and fall times, or SMPTE 292M compliance, SD/ $\overline{HD}$  is set low.

### REPLACING THE GENNUM GS1528

The CLC002 is form-fit-function compatible with the Gennum GS1528 and GS1528A.

OBSOLETE

**Physical Dimensions** inches (millimeters) unless otherwise noted

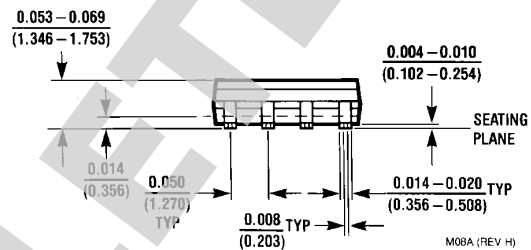
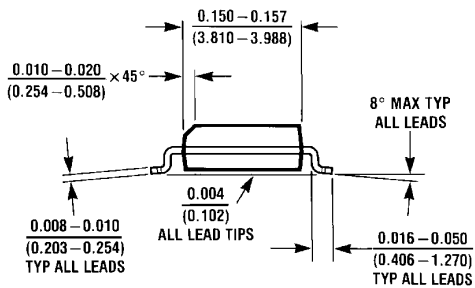
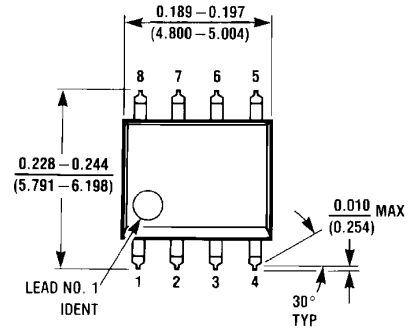

**8-Pin SOIC**  
**Order Number CLC002MA or CLC002TMA**  
**NS Package Number M08A**

OBSOLETE

## Notes

For more National Semiconductor product information and proven design tools, visit the following Web sites at:  
[www.national.com](http://www.national.com)

Products		Design Support	
Amplifiers	<a href="http://www.national.com/amplifiers">www.national.com/amplifiers</a>	WEBENCH® Tools	<a href="http://www.national.com/webench">www.national.com/webench</a>
Audio	<a href="http://www.national.com/audio">www.national.com/audio</a>	App Notes	<a href="http://www.national.com/appnotes">www.national.com/appnotes</a>
Clock and Timing	<a href="http://www.national.com/timing">www.national.com/timing</a>	Reference Designs	<a href="http://www.national.com/refdesigns">www.national.com/refdesigns</a>
Data Converters	<a href="http://www.national.com/adc">www.national.com/adc</a>	Samples	<a href="http://www.national.com/samples">www.national.com/samples</a>
Interface	<a href="http://www.national.com/interface">www.national.com/interface</a>	Eval Boards	<a href="http://www.national.com/evalboards">www.national.com/evalboards</a>
LVDS	<a href="http://www.national.com/lvds">www.national.com/lvds</a>	Packaging	<a href="http://www.national.com/packaging">www.national.com/packaging</a>
Power Management	<a href="http://www.national.com/power">www.national.com/power</a>	Green Compliance	<a href="http://www.national.com/quality/green">www.national.com/quality/green</a>
Switching Regulators	<a href="http://www.national.com/switchers">www.national.com/switchers</a>	Distributors	<a href="http://www.national.com/contacts">www.national.com/contacts</a>
LDOs	<a href="http://www.national.com/ldo">www.national.com/ldo</a>	Quality and Reliability	<a href="http://www.national.com/quality">www.national.com/quality</a>
LED Lighting	<a href="http://www.national.com/led">www.national.com/led</a>	Feedback/Support	<a href="http://www.national.com/feedback">www.national.com/feedback</a>
Voltage References	<a href="http://www.national.com/vref">www.national.com/vref</a>	Design Made Easy	<a href="http://www.national.com/easy">www.national.com/easy</a>
PowerWise® Solutions	<a href="http://www.national.com/powerwise">www.national.com/powerwise</a>	Applications & Markets	<a href="http://www.national.com/solutions">www.national.com/solutions</a>
Serial Digital Interface (SDI)	<a href="http://www.national.com/sdi">www.national.com/sdi</a>	Mil/Aero	<a href="http://www.national.com/milaero">www.national.com/milaero</a>
Temperature Sensors	<a href="http://www.national.com/tempensors">www.national.com/tempensors</a>	SolarMagic™	<a href="http://www.national.com/solarmagic">www.national.com/solarmagic</a>
PLL/VCO	<a href="http://www.national.com/wireless">www.national.com/wireless</a>	PowerWise® Design University	<a href="http://www.national.com/training">www.national.com/training</a>

THE CONTENTS OF THIS DOCUMENT ARE PROVIDED IN CONNECTION WITH NATIONAL SEMICONDUCTOR CORPORATION ("NATIONAL") PRODUCTS. NATIONAL MAKES NO REPRESENTATIONS OR WARRANTIES WITH RESPECT TO THE ACCURACY OR COMPLETENESS OF THE CONTENTS OF THIS PUBLICATION AND RESERVES THE RIGHT TO MAKE CHANGES TO SPECIFICATIONS AND PRODUCT DESCRIPTIONS AT ANY TIME WITHOUT NOTICE. NO LICENSE, WHETHER EXPRESS, IMPLIED, ARISING BY ESTOPPEL OR OTHERWISE, TO ANY INTELLECTUAL PROPERTY RIGHTS IS GRANTED BY THIS DOCUMENT.

TESTING AND OTHER QUALITY CONTROLS ARE USED TO THE EXTENT NATIONAL DEEMS NECESSARY TO SUPPORT NATIONAL'S PRODUCT WARRANTY. EXCEPT WHERE MANDATED BY GOVERNMENT REQUIREMENTS, TESTING OF ALL PARAMETERS OF EACH PRODUCT IS NOT NECESSARILY PERFORMED. NATIONAL ASSUMES NO LIABILITY FOR APPLICATIONS ASSISTANCE OR BUYER PRODUCT DESIGN. BUYERS ARE RESPONSIBLE FOR THEIR PRODUCTS AND APPLICATIONS USING NATIONAL COMPONENTS. PRIOR TO USING OR DISTRIBUTING ANY PRODUCTS THAT INCLUDE NATIONAL COMPONENTS, BUYERS SHOULD PROVIDE ADEQUATE DESIGN, TESTING AND OPERATING SAFEGUARDS.

EXCEPT AS PROVIDED IN NATIONAL'S TERMS AND CONDITIONS OF SALE FOR SUCH PRODUCTS, NATIONAL ASSUMES NO LIABILITY WHATSOEVER, AND NATIONAL DISCLAIMS ANY EXPRESS OR IMPLIED WARRANTY RELATING TO THE SALE AND/OR USE OF NATIONAL PRODUCTS INCLUDING LIABILITY OR WARRANTIES RELATING TO FITNESS FOR A PARTICULAR PURPOSE, MERCHANTABILITY, OR INFRINGEMENT OF ANY PATENT, COPYRIGHT OR OTHER INTELLECTUAL PROPERTY RIGHT.

#### LIFE SUPPORT POLICY

**NATIONAL'S PRODUCTS ARE NOT AUTHORIZED FOR USE AS CRITICAL COMPONENTS IN LIFE SUPPORT DEVICES OR SYSTEMS WITHOUT THE EXPRESS PRIOR WRITTEN APPROVAL OF THE CHIEF EXECUTIVE OFFICER AND GENERAL COUNSEL OF NATIONAL SEMICONDUCTOR CORPORATION.** As used herein:

Life support devices or systems are devices which (a) are intended for surgical implant into the body, or (b) support or sustain life and whose failure to perform when properly used in accordance with instructions for use provided in the labeling can be reasonably expected to result in a significant injury to the user. A critical component is any component in a life support device or system whose failure to perform can be reasonably expected to cause the failure of the life support device or system or to affect its safety or effectiveness.

National Semiconductor and the National Semiconductor logo are registered trademarks of National Semiconductor Corporation. All other brand or product names may be trademarks or registered trademarks of their respective holders.

Copyright© 2011 National Semiconductor Corporation

For the most current product information visit us at [www.national.com](http://www.national.com)



[www.national.com](http://www.national.com)

**National Semiconductor  
Americas Technical  
Support Center**  
Email: [support@nsc.com](mailto:support@nsc.com)  
Tel: 1-800-272-9959

**National Semiconductor Europe  
Technical Support Center**  
Email: [europe.support@nsc.com](mailto:europe.support@nsc.com)

**National Semiconductor Asia  
Pacific Technical Support Center**  
Email: [ap.support@nsc.com](mailto:ap.support@nsc.com)

**National Semiconductor Japan  
Technical Support Center**  
Email: [jpn.feedback@nsc.com](mailto:jpn.feedback@nsc.com)