

THIS DRAWING IS UNPUBLISHED. RELEASED FOR PUBLICATION
 © COPYRIGHT - By - ALL RIGHTS RESERVED.

REVISIONS				
P	LTR	DESCRIPTION	DATE	DWN / APVD
	C6	REVISED PER ECO-19-018415	10JAN20	DT / TD

- 1 CONTINUOUS STRIP ON REELS
- 2 WIRE SIZE IS #18-#14 AWG
- 3 INSULATION RANGE IS .120-.170 DIA
- 4 MATING TAB THK IS .032±.001
- 5 UL APPROVED FOR AWG 18-14
- 6 OBSOLETE/SUPERSEDED BY PN 2238196-3
- 7 PRELIMINARY-NOT FOR PRODUCTION
- 8 REELING DIRECTION AS SHOWN:

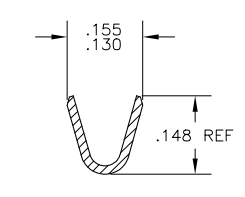
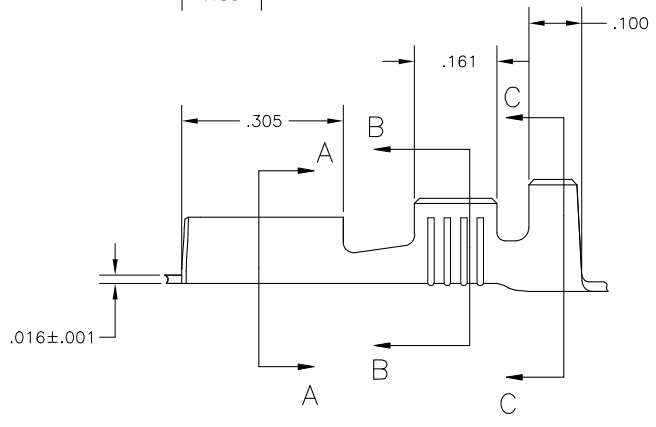
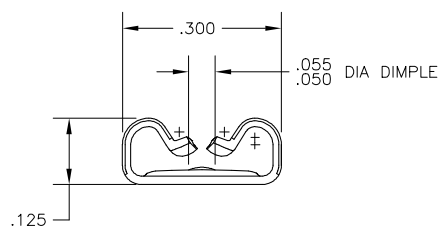
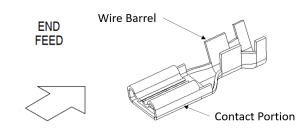
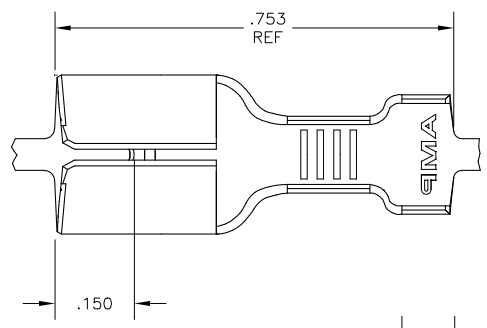

SECTION B-B

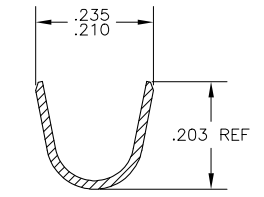

SECTION C-C

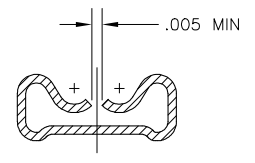

SECTION A-A

7	NICKEL PLATE	HOT STEEL	1742198-4
6/5	TIN	BRASS	1742198-3
5	NICKEL PLATE	HOT STEEL	1742198-1
	FINISH	MATERIAL	PART NO

THIS DRAWING IS A CONTROLLED DOCUMENT.		DWN jr_ruth 22OCT04	TE Connectivity	
DIMENSIONS: INCHES		CHK B FLAIG 22OCT04	RECEPTACLE, FASTON, .250 SERIES	
TOLERANCES UNLESS OTHERWISE SPECIFIED:		APVD ED HOWARD 22OCT04	NAME	
0 PLC ± -		PRODUCT SPEC 108-5178	SIZE	
1 PLC ± -		APPLICATION SPEC 114-2036	CAGE CODE	
2 PLC ± .010		WEIGHT	DRAWING NO	
3 PLC ± .010		FINISH	1742198	
4 PLC ± ± 5°		MATERIAL	RESTRICTED TO	
SEE TABLE		SEE TABLE	A2 00779 ©=1742198	
		CUSTOMER DRAWING	SCALE 6:1	SHEET 1 of 1
			REV	C6