

LM140L,LM340L

LM140L/LM340L Series 3-Terminal Positive Regulators



Literature Number: SNVS758A

LM140L/LM340L Series 3-Terminal Positive Regulators

General Description

The LM140L series of three terminal positive regulators is available with several fixed output voltages making them useful in a wide range of applications. The LM140LA is an improved version of the LM78LXX series with a tighter output voltage tolerance (specified over the full military temperature range), higher ripple rejection, better regulation and lower quiescent current. The LM140LA regulators have $\pm 2\%$ V_{OUT} specification, 0.04%/V line regulation, and 0.01%/mA load regulation. When used as a zener diode/resistor combination replacement, the LM140LA usually results in an effective output impedance improvement of two orders of magnitude, and lower quiescent current. These regulators can provide local on card regulation, eliminating the distribution problems associated with single point regulation. The voltages available allow the LM140LA to be used in logic systems, instrumentation, Hi-Fi, and other solid state electronic equipment. Although designed primarily as fixed voltage regulators, these devices can be used with external components to obtain adjustable voltages and currents.

The LM140LA/LM340LA are available in the low profile metal three lead TO-39 (H) and the LM340LA are also available in the plastic TO-92 (Z). With adequate heat sinking the regulator can deliver 100 mA output current. Current limiting is included to limit the peak output current to a safe value. Safe area protection for the output transistor is pro-

vided to limit internal power dissipation. If internal power dissipation becomes too high for the heat sinking provided, the thermal shut-down circuit takes over, preventing the IC from overheating.

For applications requiring other voltages, see LM117L Data Sheet.

Features

- Line regulation of 0.04%/V
- Load regulation of 0.01%/mA
- Output voltage tolerances of $\pm 2\%$ at $T_j = 25^\circ\text{C}$ and $\pm 4\%$ over the temperature range (LM140LA) $\pm 3\%$ over the temperature range (LM340LA)
- Output current of 100 mA
- Internal thermal overload protection
- Output transistor safe area protection
- Internal short circuit current limit
- Available in metal TO-39 low profile package (LM140LA/LM340LA) and plastic TO-92 (LM340LA)

Output Voltage Options

LM140LA-5.0	5V	LM340LA-5.0	5V
LM140LA-12	12V	LM340LA-12	12V
LM140LA-15	15V	LM340LA-15	15V

Connection Diagrams

TO-39 Metal Can Package (H)

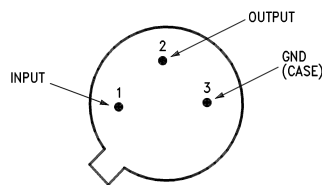

00778202

Bottom View

Order Number LM140LAH-5.0, LM140LAH-5.0/883, LM140LAH-12, LM140LAH-12/883, LM140LAH-15, LM140LAH-15/883, LM340LAH-5.0, LM340LAH-12 or LM340LAH-15
See NS Package Number H03A

Connection Diagrams (Continued)

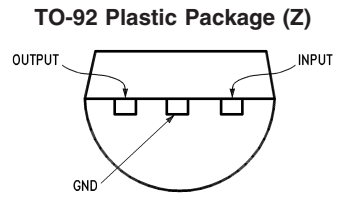

00778203

Bottom View

Order Number LM340LAZ-5.0, LM340LAZ-12 or LM340LAZ-15
See NS Package Number Z03A

Absolute Maximum Ratings (Note 1)

If Military/Aerospace specified devices are required, please contact the National Semiconductor Sales Office/Distributors for availability and specifications.

(Note 5)

Input Voltage	35V
Internal Power Dissipation (Note 2)	Internally Limited
Operating Temperature Range	
LM140LA	-55°C to +125°C
LM340LA	0°C to +70°C

Maximum Junction Temperature	+150°C
Storage Temperature Range	
Metal Can (H package)	-65°C to +150°C
Molded TO-92	-55°C to +150°C
Lead Temperature (Soldering, 10 sec.)	
Metal Can	+300°C
Plastic TO-92	+230°C

Electrical Characteristics

Test conditions unless otherwise specified. $T_A = -55^\circ\text{C}$ to $+125^\circ\text{C}$ (LM140LA), $T_A = 0^\circ\text{C}$ to $+70^\circ\text{C}$ (LM340LA), $I_O = 40\text{ mA}$, $C_{IN} = 0.33\text{ }\mu\text{F}$, $C_O = 0.01\text{ }\mu\text{F}$.

Output Voltage Option			5.0V			12V			15V			Units
Input Voltage (unless otherwise noted)			10V			19V			23V			
Symbol	Parameter	Conditions	Min	Typ	Max	Min	Typ	Max	Min	Typ	Max	
V_O	Output Voltage	$T_j = 25^\circ\text{C}$	4.9	5	5.1	11.75	12	12.25	14.7	15	15.3	V
	Output Voltage Over Temp. (Note 4)	LM140LA $I_O = 1 - 100\text{ mA}$	4.8		5.2	11.5		12.5	14.4		15.6	
		LM340LA $I_O = 1 - 100\text{ mA}$ or $I_O = 1 - 40\text{ mA}$ and $V_{IN} = ()\text{V}$	4.85		5.15	11.65		12.35	14.55		15.45	
			(7.2-20)			(14.5-27)			(17.6-30)			
ΔV_O	Line Regulation	$T_j = 25^\circ\text{C}$	18 30		30 65		37 70		mV			
		$I_O = 40\text{ mA}$ $V_{IN} = ()\text{V}$	(7-25)		(14.2-30)		(17.3-30)					
		$I_O = 100\text{ mA}$ $V_{IN} = ()\text{V}$	18 30		30 65		37 70					
			(7.5-25)		(14.5-30)		(17.5-30)					
	Load Regulation	$T_j = 25^\circ\text{C}$	5 20		10 40		12 50		mV			
		$I_O = 1 - 40\text{ mA}$ $I_O = 1 - 100\text{ mA}$	20 40		30 80		35 100					
	Long Term Stability		12		24		30		mV 1000 hrs			
I_O	Quiescent Current	$T_j = 25^\circ\text{C}$ $T_j = 125^\circ\text{C}$	3 4.5		3 4.5		3.1 4.5		mA			
ΔI_O	Quiescent Current Change	$T_j = 25^\circ\text{C}$	0.1		0.1		0.1		mA			
		$\Delta\text{Load } I_O = 1 - 40\text{ mA}$	0.5		0.5		0.5					
		ΔLine $V_{IN} = ()\text{V}$	(7.5-25)		(14.3-30)		(17.5-30)					
V_N	Output Noise Voltage	$T_j = 25^\circ\text{C}$ (Note 3) $f = 10\text{ Hz} - 10\text{ kHz}$	40		80		90		μV			
$\frac{\Delta V_{IN}}{\Delta V_{OUT}}$	Ripple Rejection	$f = 120\text{ Hz}$, $V_{IN} = ()\text{V}$	55 62		47 54		45 52		dB			
			(7.5-18)		(14.5-25)		(17.5-28.5)					
	Input Voltage Required to Maintain Line Regulation	$T_j = 25^\circ\text{C}$, $I_O = 40\text{ mA}$	7		14.2		17.3		V			

Note 1: "Absolute Maximum Ratings" indicate limits beyond which damage to the device may occur. Operating Ratings indicate conditions for which the device is functional, but do not guarantee specific performance limits.

Note 2: Thermal resistance of H-package is typically 26°C/W θ_{JC} , 250°C/W θ_{JA} still air, and 94°C/W θ_{JA} 400 lf/min of air. For the Z-package is 60°C/W θ_{JC} , 232°C/W θ_{JA} still air, and 88°C/W θ_{JA} at 400 lf/min of air. The maximum junction temperature shall not exceed 125°C on electrical parameters.

Note 3: It is recommended that a minimum load capacitor of $0.01\text{ }\mu\text{F}$ be used to limit the high frequency noise bandwidth.

Note 4: The temperature coefficient of V_{OUT} is typically within 0.01% $V_O/^\circ\text{C}$.

Note 5: A military RETS specification is available upon request. At the time of printing, the LM140LA-5.0, -12, and -15 RETS specifications complied with the Min and Max limits in this table. The LM140LAH-5.0, LM140LAH-12, and LM140LAH-15 may also be procured as Standard Military Drawings.

Typical Performance Characteristics

Maximum Average Power Dissipation

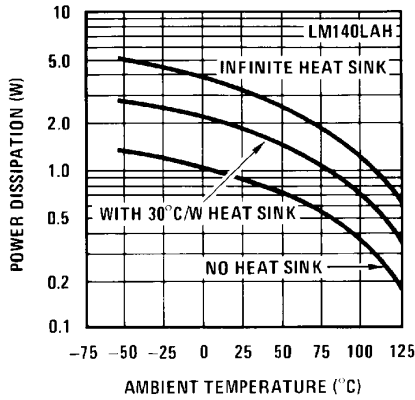

Maximum Average Power Dissipation (Metal Can Package)

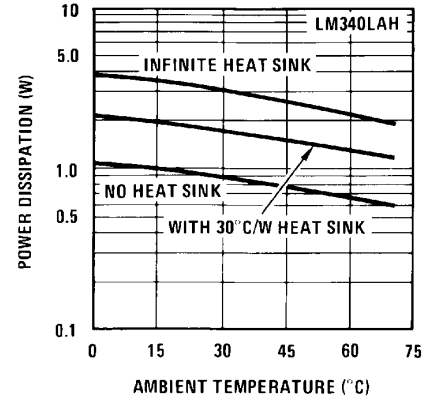

Maximum Average Power Dissipation (Plastic Package)

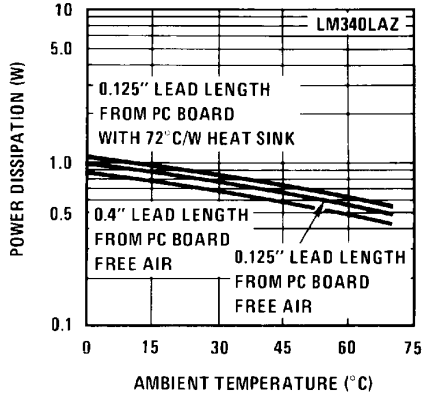

Peak Output Current

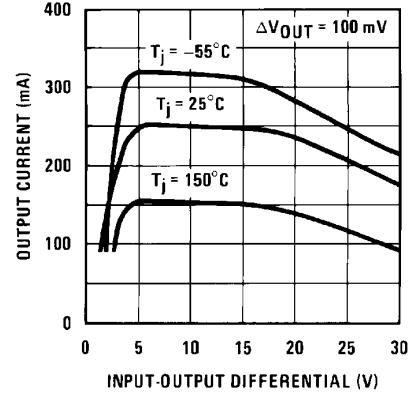

Dropout Voltage

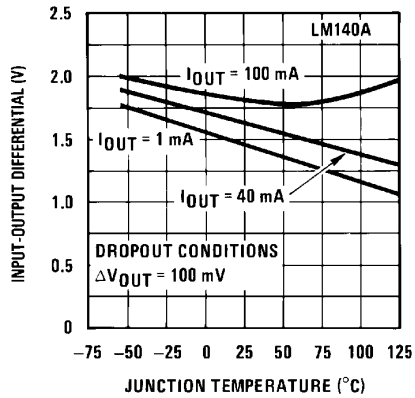

Output Impedance

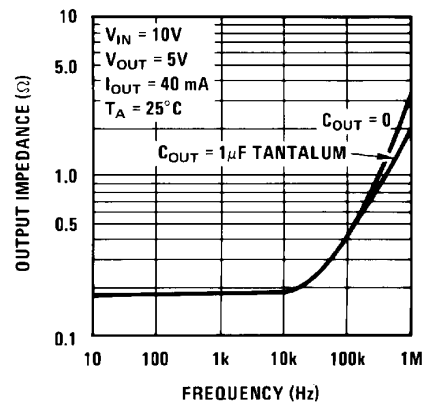

Typical Performance Characteristics (Continued)

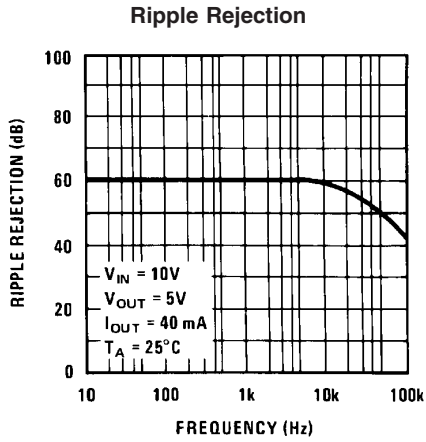

00778213

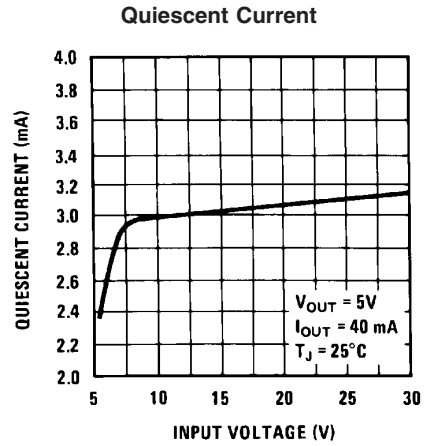

00778214

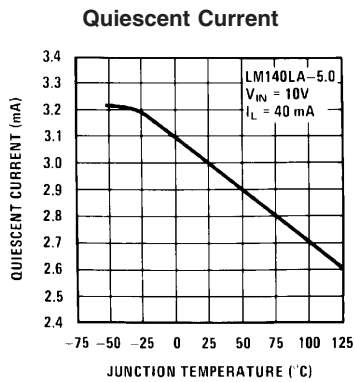

00778215

Typical Applications

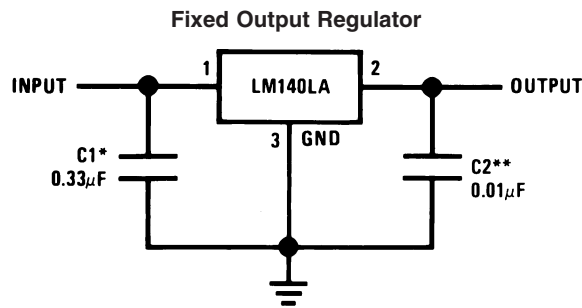

00778205

*Required if the regulator is located far from the power supply filter.

**See note 3 in the electrical characteristics table.

Typical Applications (Continued)

Adjustable Output Regulator

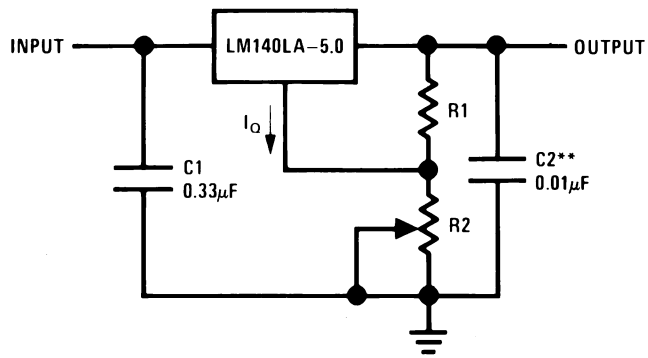

00778206

$$V_{OUT} = 5V + (5V/R1 + I_O) R2$$

$$5V/R1 = 3 I_O \text{ load regulation (L.) } [(R1 + R2)/R1] \text{ (L. of LM140LA-5.0)}$$

Equivalent Circuit

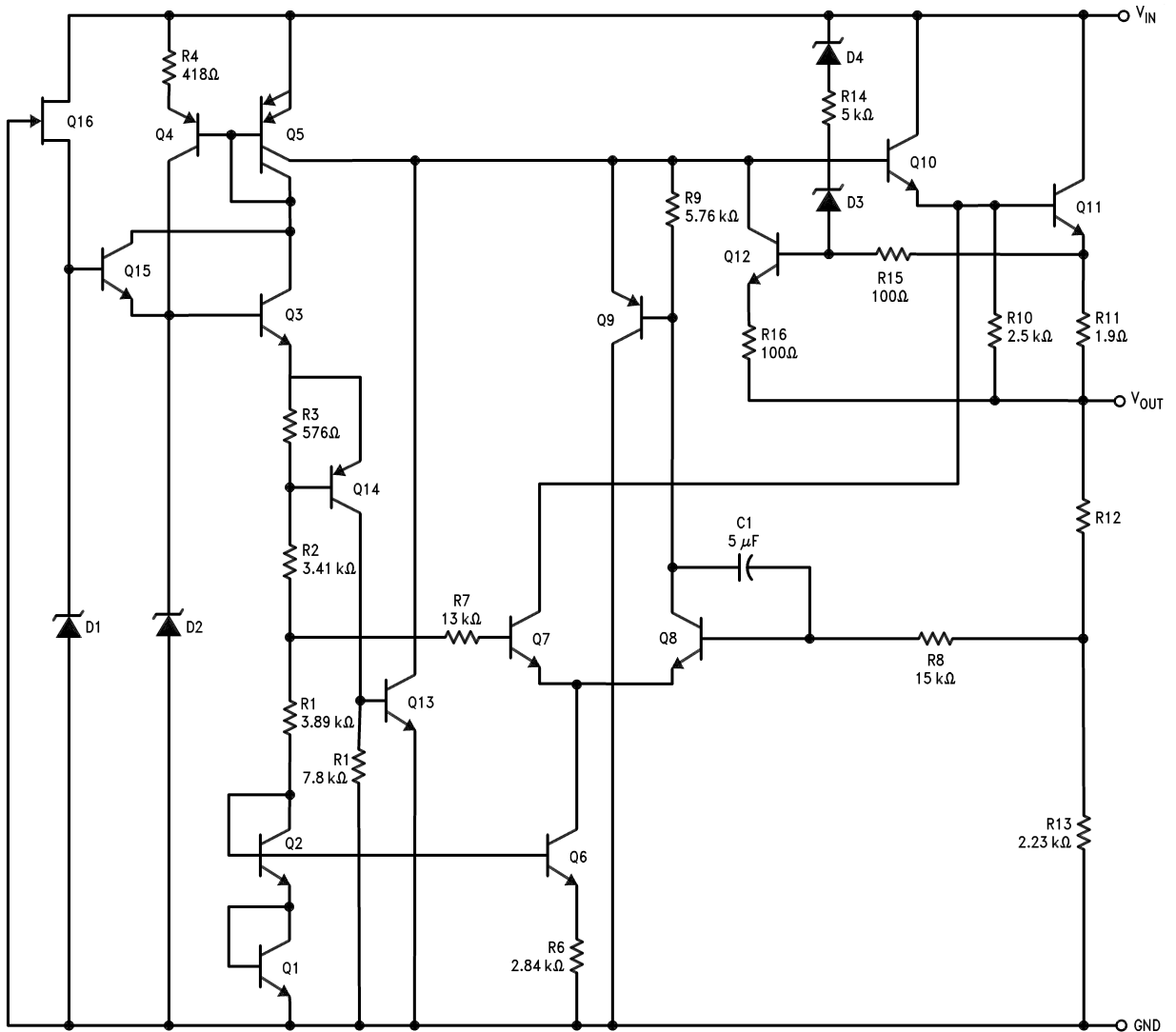

00778201

Physical Dimensions inches (millimeters) unless otherwise noted

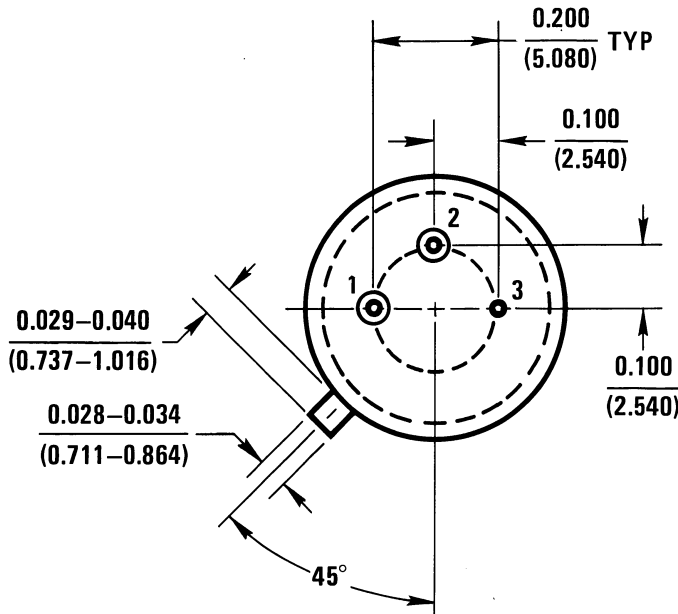
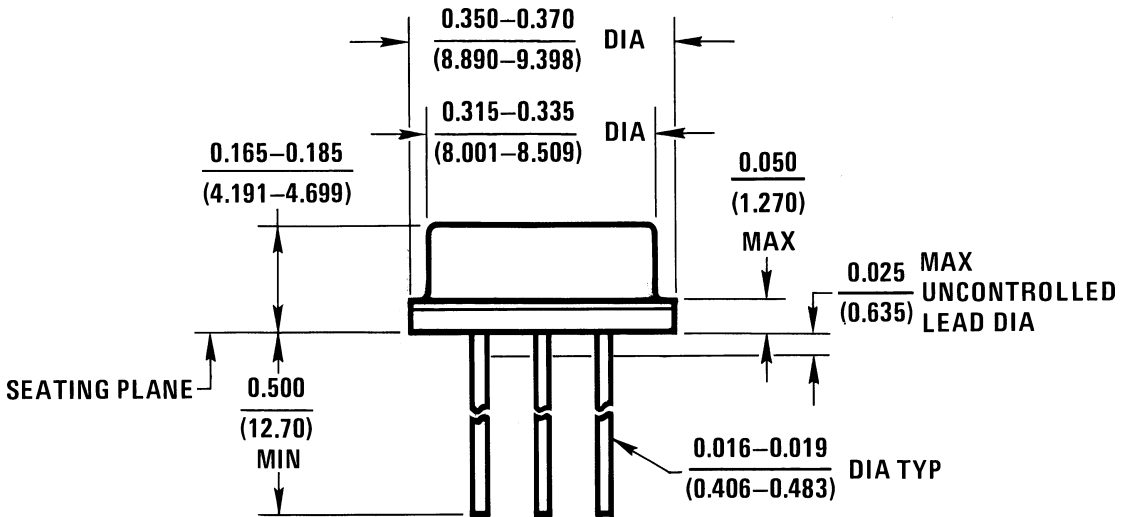

H03A (REV B)

TO-39 Metal Can Package (H)
 Order Number LM140LAH-5.0, LM140LAH-5.0/883, LM140LAH-12, LM140LAH-12/883,
 LM140LAH-15, LM140LAH-15/883, LM340LAH-5.0, LM340LAH-12 or LM340LAH-15
 NS Package Number H03A

Physical Dimensions inches (millimeters) unless otherwise noted (Continued)

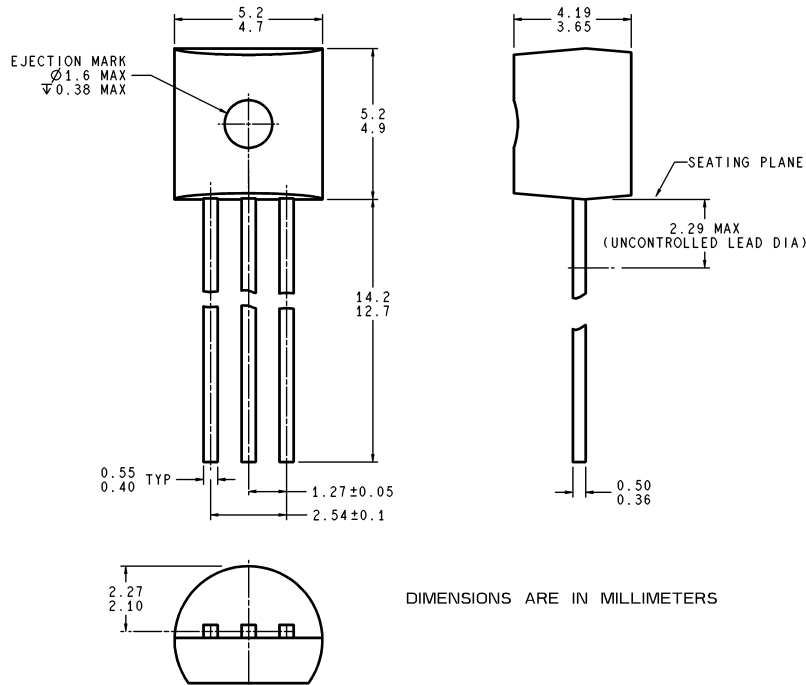

Z03A (Rev 6)

TO-92 Plastic Package (Z)
Order Number LM340LAZ-5.0, LM340LAZ-12, or LM340LAZ-15
NS Package Number Z03A

National does not assume any responsibility for use of any circuitry described, no circuit patent licenses are implied and National reserves the right at any time without notice to change said circuitry and specifications.

For the most current product information visit us at www.national.com.

LIFE SUPPORT POLICY

NATIONAL'S PRODUCTS ARE NOT AUTHORIZED FOR USE AS CRITICAL COMPONENTS IN LIFE SUPPORT DEVICES OR SYSTEMS WITHOUT THE EXPRESS WRITTEN APPROVAL OF THE PRESIDENT AND GENERAL COUNSEL OF NATIONAL SEMICONDUCTOR CORPORATION. As used herein:

1. Life support devices or systems are devices or systems which, (a) are intended for surgical implant into the body, or (b) support or sustain life, and whose failure to perform when properly used in accordance with instructions for use provided in the labeling, can be reasonably expected to result in a significant injury to the user.
2. A critical component is any component of a life support device or system whose failure to perform can be reasonably expected to cause the failure of the life support device or system, or to affect its safety or effectiveness.

BANNED SUBSTANCE COMPLIANCE

National Semiconductor manufactures products and uses packing materials that meet the provisions of the Customer Products Stewardship Specification (CSP-9-111C2) and the Banned Substances and Materials of Interest Specification (CSP-9-111S2) and contain no "Banned Substances" as defined in CSP-9-111S2.

Leadfree products are RoHS compliant.



National Semiconductor
Americas Customer
Support Center
 Email: new.feedback@nsc.com
 Tel: 1-800-272-9959

National Semiconductor
Europe Customer Support Center
 Fax: +49 (0) 180-530 85 86
 Email: europa.support@nsc.com
 Deutsch Tel: +49 (0) 69 9508 6208
 English Tel: +44 (0) 870 24 0 2171
 Français Tel: +33 (0) 1 41 91 8790

National Semiconductor
Asia Pacific Customer
Support Center
 Email: ap.support@nsc.com

National Semiconductor
Japan Customer Support Center
 Fax: 81-3-5639-7507
 Email: jpn.feedback@nsc.com
 Tel: 81-3-5639-7560

IMPORTANT NOTICE

Texas Instruments Incorporated and its subsidiaries (TI) reserve the right to make corrections, modifications, enhancements, improvements, and other changes to its products and services at any time and to discontinue any product or service without notice. Customers should obtain the latest relevant information before placing orders and should verify that such information is current and complete. All products are sold subject to TI's terms and conditions of sale supplied at the time of order acknowledgment.

TI warrants performance of its hardware products to the specifications applicable at the time of sale in accordance with TI's standard warranty. Testing and other quality control techniques are used to the extent TI deems necessary to support this warranty. Except where mandated by government requirements, testing of all parameters of each product is not necessarily performed.

TI assumes no liability for applications assistance or customer product design. Customers are responsible for their products and applications using TI components. To minimize the risks associated with customer products and applications, customers should provide adequate design and operating safeguards.

TI does not warrant or represent that any license, either express or implied, is granted under any TI patent right, copyright, mask work right, or other TI intellectual property right relating to any combination, machine, or process in which TI products or services are used. Information published by TI regarding third-party products or services does not constitute a license from TI to use such products or services or a warranty or endorsement thereof. Use of such information may require a license from a third party under the patents or other intellectual property of the third party, or a license from TI under the patents or other intellectual property of TI.

Reproduction of TI information in TI data books or data sheets is permissible only if reproduction is without alteration and is accompanied by all associated warranties, conditions, limitations, and notices. Reproduction of this information with alteration is an unfair and deceptive business practice. TI is not responsible or liable for such altered documentation. Information of third parties may be subject to additional restrictions.

Resale of TI products or services with statements different from or beyond the parameters stated by TI for that product or service voids all express and any implied warranties for the associated TI product or service and is an unfair and deceptive business practice. TI is not responsible or liable for any such statements.

TI products are not authorized for use in safety-critical applications (such as life support) where a failure of the TI product would reasonably be expected to cause severe personal injury or death, unless officers of the parties have executed an agreement specifically governing such use. Buyers represent that they have all necessary expertise in the safety and regulatory ramifications of their applications, and acknowledge and agree that they are solely responsible for all legal, regulatory and safety-related requirements concerning their products and any use of TI products in such safety-critical applications, notwithstanding any applications-related information or support that may be provided by TI. Further, Buyers must fully indemnify TI and its representatives against any damages arising out of the use of TI products in such safety-critical applications.

TI products are neither designed nor intended for use in military/aerospace applications or environments unless the TI products are specifically designated by TI as military-grade or "enhanced plastic." Only products designated by TI as military-grade meet military specifications. Buyers acknowledge and agree that any such use of TI products which TI has not designated as military-grade is solely at the Buyer's risk, and that they are solely responsible for compliance with all legal and regulatory requirements in connection with such use.

TI products are neither designed nor intended for use in automotive applications or environments unless the specific TI products are designated by TI as compliant with ISO/TS 16949 requirements. Buyers acknowledge and agree that, if they use any non-designated products in automotive applications, TI will not be responsible for any failure to meet such requirements.

Following are URLs where you can obtain information on other Texas Instruments products and application solutions:

Products

Audio	www.ti.com/audio
Amplifiers	amplifier.ti.com
Data Converters	dataconverter.ti.com
DLP® Products	www.dlp.com
DSP	dsp.ti.com
Clocks and Timers	www.ti.com/clocks
Interface	interface.ti.com
Logic	logic.ti.com
Power Mgmt	power.ti.com
Microcontrollers	microcontroller.ti.com
RFID	www.ti-rfid.com
OMAP Mobile Processors	www.ti.com/omap
Wireless Connectivity	www.ti.com/wirelessconnectivity

Applications

Communications and Telecom	www.ti.com/communications
Computers and Peripherals	www.ti.com/computers
Consumer Electronics	www.ti.com/consumer-apps
Energy and Lighting	www.ti.com/energy
Industrial	www.ti.com/industrial
Medical	www.ti.com/medical
Security	www.ti.com/security
Space, Avionics and Defense	www.ti.com/space-avionics-defense
Transportation and Automotive	www.ti.com/automotive
Video and Imaging	www.ti.com/video

TI E2E Community Home Page

e2e.ti.com

Mailing Address: Texas Instruments, Post Office Box 655303, Dallas, Texas 75265
Copyright © 2011, Texas Instruments Incorporated