

---

## Externally Programmable Dual High-Current Step-Down DC/DC and Dual Linear Regulators

---

### General Description

The LM26480 is a multi-functional Power Management Unit, optimized for low-power digital applications. This device integrates two highly efficient 1.5A step-down DC/DC converters and two 300 mA linear regulators. The LM26480 is offered in a tiny 4 x 4 x 0.8mm LLP-24 pin package.

### Key Specifications

#### Step-Down DC/DC Converter (Buck)

- 1.5A output current
- $V_{OUT}$  from:
  - Buck1 : 0.8V–2.0V @ 1.5A
  - Buck2 : 1.0V–3.3V @ 1.5A
- Up to 96% efficiency
- $\pm 3\%$  FB voltage accuracy
- 2 MHz PWM switching frequency
- PWM - PFM automatic mode change under low loads
- Automatic soft start

#### Linear Regulators (LDO)

- $V_{OUT}$  of 1.0V–3.5V
- $\pm 3\%$  FB voltage accuracy

- 300 mA output current
- 25 mV (typ) dropout

### Features

- Compatible with advanced applications processors and FPGAs
- 2 LDOs for powering Internal processor functions and I/Os
- Precision internal reference
- Thermal overload protection
- Current overload protection
- 24-lead 4 x 4 x 0.8mm LLP package
- External Power-On-Reset function for Buck1 and Buck2
- Undervoltage lock-out detector to monitor input supply voltage
- Note: LM26480Q is an Automotive-Grade product that is AECQ-100 Grade 1 qualified.

### Applications

- Core digital power
- Applications processors
- Peripheral I/O power

# Typical Application Circuit

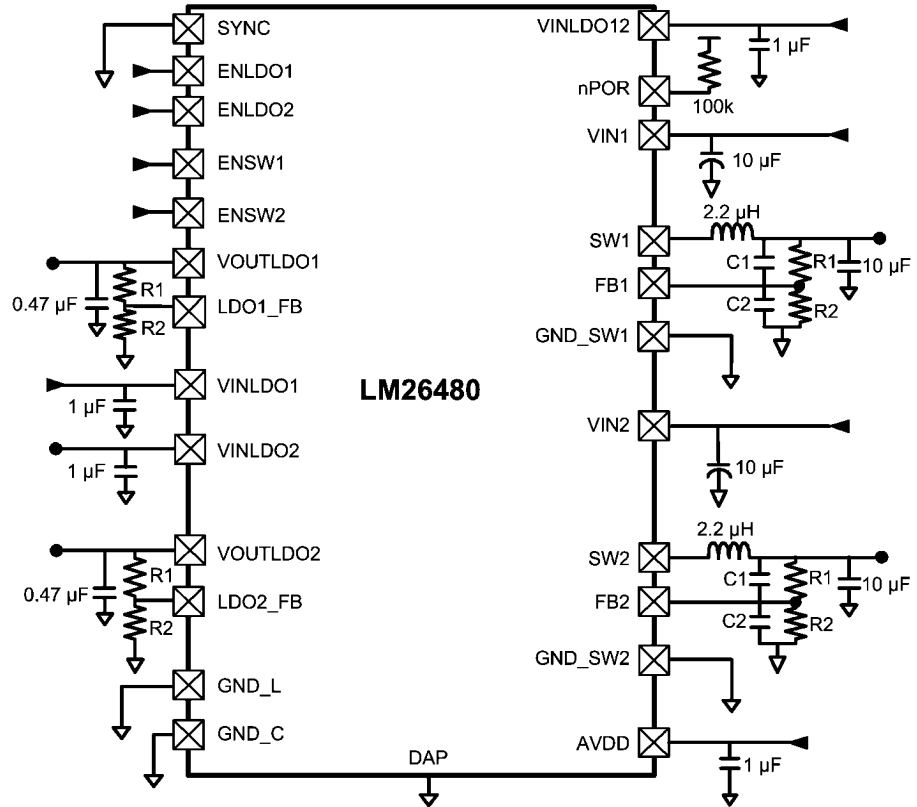

30040401

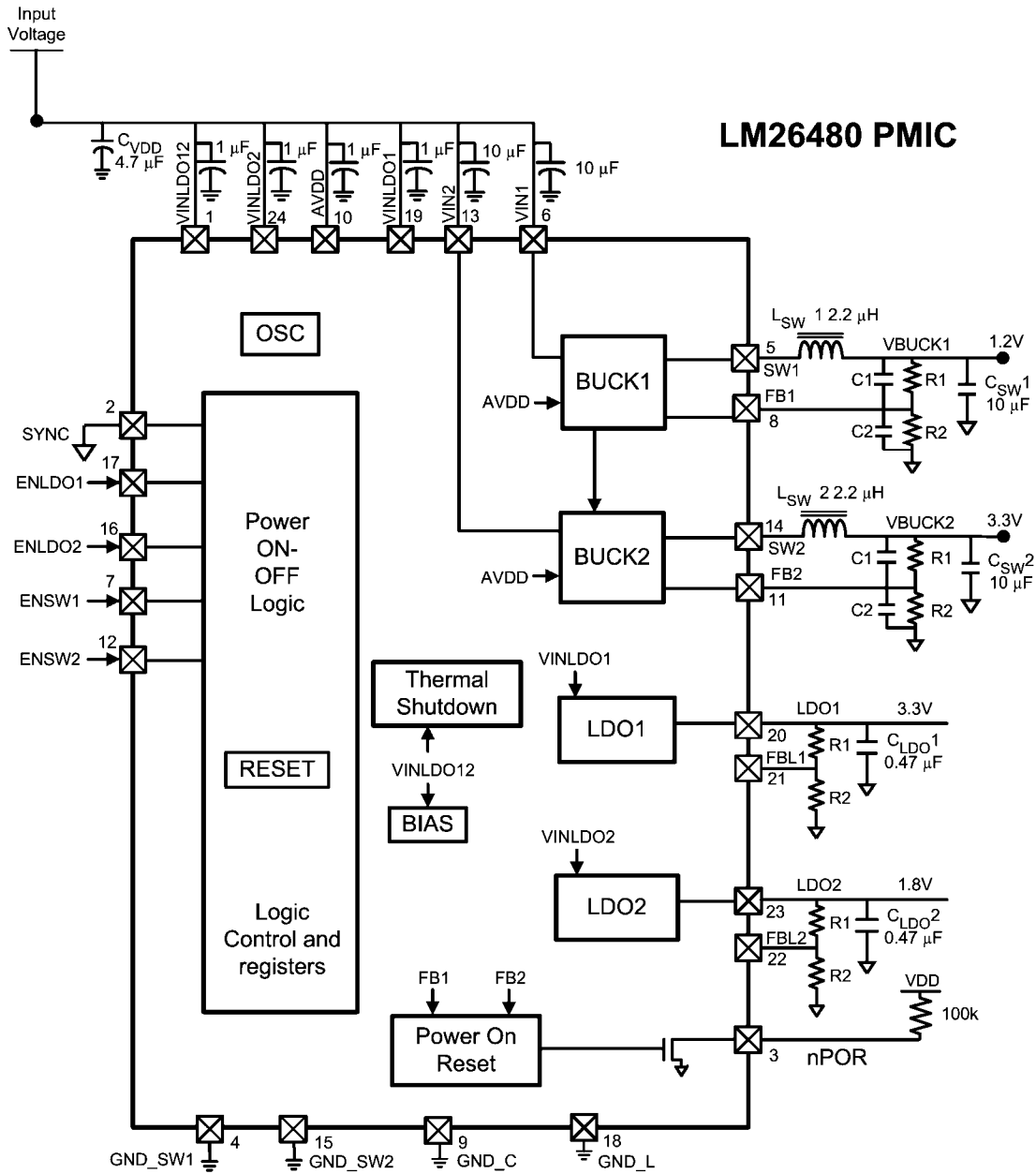

30040402

FIGURE 1. Application Circuit

## Connection Diagrams and Package Mark Information

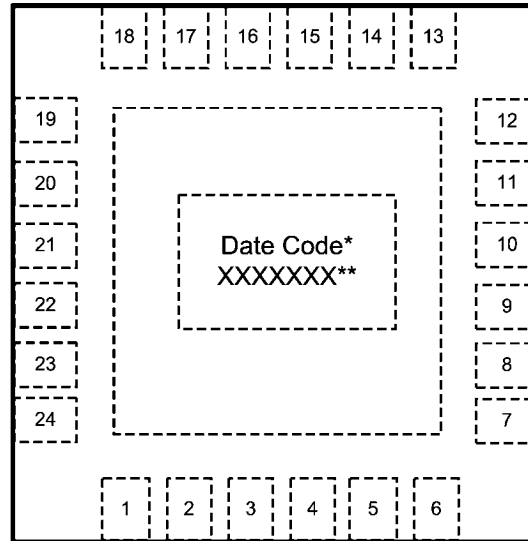

30040403

**FIGURE 2. 24-Lead LLP Package (top view)**

Note: The physical placement of the package marking will vary from part to part.

(\*) UZXYTT format: 'U' – wafer fab code; 'Z' – assembly code; 'XY' 2 digit date code; 'TT' – die run code.

(\*\*) Package received will have XXXXXX replaced with the specific part version ordered.

## Ordering Information

Part Number	Spec	Top Mark	Quantity
LM26480SQ-AA	NOPB	26480AA	1000 tape and reel
LM26480SQX-AA	NOPB	26480AA	4500 tape and reel
LM26480QSQ-AA	NOPB	26480QA	1000 tape and reel
LM26480QSQX-AA	NOPB	26480QA	4500 tape and reel
LM26480QSQ-CF	NOPB	26480CF	1000 tape and reel
LM26480QSQX-CF	NOPB	26480CF	4500 tape and reel
LM26480SQ-BF	NOPB	26480BF	1000 tape and reel
LM26480SQX-BF	NOPB	26480BF	4500 tape and reel
LM26480QSQ-8D	NOPB	26480QD	1000 tape and reel
LM26480QSQX-8D	NOPB	26480QD	4500 tape and reel

## Default Options

Order Suffix	Spec	Oscillator Frequency	Buck Modes	nPOR Delay	UVLO	Sync	AECQ
SQ-AA	NOPB	2.0 MHz	Auto-Mode	60 mS	Enabled	Disabled	No
QSQ-AA	NOPB	2.0 MHz	Auto-Mode	60 mS	Enabled	Disabled	Grade 1
QSQ-CF	NOPB	2.1 MHz	Forced PWM	60 mS	Disabled	Disabled	Grade 1
SQ-BF	NOPB	2.0 MHz	Forced PWM	60 mS	Enabled	Enabled	No
QSQ-8D	NOPB	2.1 MHz	Forced PWM	130 $\mu$ S	Enabled	Disabled	Grade 1

## Pin Descriptions

LLP Pin No.	Name	I/O	Type	Description
1	VINLDO12	I	PWR	Analog Power for Internal Functions (VREF, BIAS, I <sup>2</sup> C, Logic)
2	SYNC	I	G/(D)	Frequency Synchronization pin which allows the user to connect an external clock signal to synchronize the PMIC internal oscillator. Default OFF and must be grounded when not used. Part number LM26480SQ-BF has this feature enabled. Please contact Texas Instruments Sales Office/Distributors for availability of LM26480SQ-BF.
3	NPOR	O	D	nPOR Power on reset pin for both Buck1 and Buck 2. Open drain logic output 100K pullup resistor. nPOR is pulled to ground when the voltages on these supplies are not good. See nPOR section for more info.
4	GND_SW1	G	G	Buck1 NMOS Power Ground
5	SW1	O	PWR	Buck1 switcher output pin
6	VIN1	I	PWR	Power in from either DC source or Battery to Buck1
7	ENSW1	I	D	Enable Pin for Buck1 switcher, a logic HIGH enables Buck1. Pin cannot be left floating.
8	FB1	I	A	Buck1 input feedback terminal
9	GND_C	G	G	Non-switching core ground pin
10	AVDD	I	PWR	Analog Power for Buck converters
11	FB2	I	A	Buck2 input feedback terminal
12	ENSW2	I	D	Enable Pin for Buck2 switcher, a logic HIGH enables Buck2. Pin cannot be left floating.
13	VIN2	I	PWR	Power in from either DC source or Battery to Buck2
14	SW2	O	PWR	Buck2 switcher output pin
15	GND_SW2	G	G	Buck2 NMOS
16	ENLDO2	I	D	LDO2 enable pin, a logic HIGH enables LDO2. Pin cannot be left floating.
17	ENLDO1	I	D	LDO1 enable pin, a logic HIGH enables LDO1. Pin cannot be left floating.
18	GND_L	G	G	LDO ground
19	VINLDO1	I	PWR	Power in from either DC source or battery to LDO1
20	LDO1	O	PWR	LDO1 Output
21	FBL1	I	A	LDO1 Feedback Terminal
22	FBL2	I	A	LDO2 Feedback Terminal
23	LDO2	O	PWR	LDO Output
24	VINLDO2	I	PWR	Power in from either DC source or battery to LDO2.
DAP	DAP	GND	GND	Connection isn't necessary for electrical performance, but it is recommended for better thermal dissipation.

**A:** Analog Pin    **D:** Digital Pin    **G:** Ground Pin    **PWR:** Power Pin    **I:** Input Pin    **I/O:** Input/Output Pin    **O:** Output Pin

	Power Block Operation		Note
	Enabled	Disabled	
Power Block Input	VIN+	VIN+	
VINLDO12	VIN+	VIN+	Always Powered
AVDD	VIN+	VIN+	Always Powered
VIN1	VIN+	VIN+ or 0V	
VIN2	VIN+	VIN+ or 0V	
VINLDO1	≤ VIN+	≤ VIN+	If Enabled, Min VIN is 1.74V
VINLDO2	≤ VIN+	≤ VIN+	If Enabled, Min VIN is 1.74V

VIN+ is the largest potential voltage on the device.

## Absolute Maximum Ratings *(Note 1, Note 2)*

If Military/Aerospace specified devices are required, please contact the Texas Instruments Sales Office/ Distributors for availability and specifications.

VINLDO12, VIN1, AVDD, VIN2, VINLDO1, VINLDO2, ENSW1, FB1, FB2, ENSW2, ENLDO1, ENLDO2, SYNC, FBL1, FBL2	-0.3V to +6V
GND to GND SLUG	±0.3V
Power Dissipation ( $P_{D\_MAX}$ ) ( $T_A=85^\circ\text{C}$ , $T_{MAX}=125^\circ\text{C}$ ) <i>(Note 5)</i>	1.17W
Junction Temperature ( $T_{J\_MAX}$ )	150°C
Storage Temperature Range	-65°C to +150°C
Maximum Lead Temperature (Soldering)	260°C

### ESD Ratings

Human Body Model <i>(Note 4)</i>	2 kV
----------------------------------	------

## Operating Ratings: Bucks *(Note 1, Note 2, Note 7)*

$V_{IN}$	2.8V to 5.5V
$V_{EN}$	0 to ( $V_{IN} + 0.3V$ )
Junction Temperature ( $T_J$ ) Range	-40°C to +125°C
Ambient Temperature ( $T_A$ ) Range <i>(Note 6)</i>	-40°C to +85°C

## Thermal Properties *(Note 3, Note 5, Note 6)*

Junction-to-Ambient Thermal Resistance ( $\theta_{JA}$ ) SQA024AG	34.1°C/W
---	----------

## General Electrical Characteristics *(Note 1, Note 2, Note 7, Note 13, Note 16)*

Unless otherwise noted,  $V_{IN} = 3.6V$ . Typical values and limits appearing in normal type apply for  $T_J = 25^\circ\text{C}$ . Limits appearing in **boldface type** apply over the entire junction temperature range for operation, -40°C to +125°C.

Symbol	Parameter	Conditions	Min	Typ	Max	Units
$I_Q$	VINLDO12 Shutdown Current	$V_{IN} = 3.6V$		0.5		μA
$V_{POR}$	Power-On Reset Threshold	$V_{DD}$ Falling Edge <i>(Note 16)</i>		1.9		V
$T_{SD}$	Thermal Shutdown Threshold	<i>(Note 13)</i>		160		°C
$T_{SDH}$	Thermal Shutdown Hysteresis	<i>(Note 13)</i>		20		°C
UVLO	Under Voltage Lock Out	Rising		2.9		V
		Falling		2.7		V

## Low Drop Out Regulators, LDO1 and LDO2

Unless otherwise noted,  $V_{IN} = 3.6V$ ,  $C_{IN} = 1.0 \mu\text{F}$ ,  $C_{OUT} = 0.47 \mu\text{F}$ . Typical values and limits appearing in normal type apply for  $T_J = 25^\circ\text{C}$ . Limits appearing in **boldface type** apply over the entire junction temperature range for operation, -40°C to +125°C. *(Note 2, Note 7, Note 8, Note 9)*

Symbol	Parameter	Conditions	Min	Typ	Max	Units
$V_{IN}$	Operational Voltage Range	VINLDO1 and VINLDO2 PMOS pins <i>(Note 15)</i>	<b>1.74</b>		<b>5.5</b>	V
$V_{FB}$	FB Voltage Accuracy		<b>-3</b>		<b>3</b>	%
$\Delta V_{OUT}$	Line Regulation	$V_{IN} = (V_{OUT} + 0.3V)$ to 5.0V <i>(Note 12)</i> Load Current = 1 mA			<b>0.15</b>	%/V
	Load Regulation	$V_{IN} = 3.6V$ , Load Current = 1 mA to $I_{MAX}$			<b>0.011</b>	%/mA
$I_{SC}$	Short Circuit Current Limit	LDO1-2, $V_{OUT} = 0V$		500		mA
$V_{IN} - V_{OUT}$	Dropout Voltage	Load Current = 50 mA <i>(Note 10)</i>		25	<b>200</b>	mV
PSRR	Power Supply Ripple Rejection	$F = 10 \text{ kHz}$ , Load Current = $I_{MAX}$		45		dB
$\theta_n$	Supply Output Noise	10 Hz < F < 100 kHz		150		μVrms

Symbol	Parameter	Conditions	Min	Typ	Max	Units
$I_q$	Quiescent Current "On"	$I_{OUT} = 0$ mA		40	<b>150</b>	$\mu$ A
	Quiescent Current "On"	$I_{OUT} = 300$ mA		60	<b>200</b>	$\mu$ A
	Quiescent Current "Off"	EN is de-asserted		0.03	1	$\mu$ A
$T_{ON}$	Turn On Time	Start up from shut-down		300		$\mu$ sec
$C_{OUT}$	Output Capacitor	Capacitance for stability $0^\circ\text{C} \leq T_J \leq 125^\circ\text{C}$	<b>0.33</b>	0.47		$\mu$ F
		$-40^\circ\text{C} \leq T_J \leq 125^\circ\text{C}$	<b>0.68</b>	1.0		$\mu$ F
		ESR (Equivalent Series Resistance)	<b>5</b>		<b>500</b>	m $\Omega$

## Buck Converters SW1, SW2

Unless otherwise noted,  $V_{IN} = 3.6$ V,  $C_{IN} = 10$   $\mu$ F,  $C_{OUT} = 10$   $\mu$ F,  $L_{OUT} = 2.2$   $\mu$ H. Typical values and limits appearing in normal type apply for  $T_J = 25^\circ\text{C}$ . Limits appearing in **boldface type** apply over the entire junction temperature range for operation,  $-40^\circ\text{C}$  to  $+125^\circ\text{C}$ . (([Note 2](#), [Note 7](#), [Note 8](#), [Note 9](#), [Note 11](#), [Note 14](#))

Symbol	Parameter	Conditions	Min	Typ	Max	Units
$V_{FB}$ ( <a href="#">Note 14</a> )	Feedback Voltage		-3		+3	%
$V_{OUT}$	Line Regulation	$2.8 < V_{IN} < 5.5$ $I_O = 10$ mA		0.089		%/V
	Load Regulation	$100$ mA $< I_O < I_{MAX}$		0.0013		%/mA
Eff	Efficiency	Load Current = 250 mA		96		%
$I_{SHDN}$	Shutdown Supply Current	EN is de-asserted		0.01	1	$\mu$ A
$f_{OSC}$	Internal Oscillator Frequency	Default oscillator frequency = 2.0 MHz	1.6	2.0	2.4	MHz
		Default oscillator frequency = 2.1 MHz	<b>1.7</b>	2.1	2.5	
$I_{PEAK}$	Buck1 Peak Switching Current Limit			2.0	2.4	A
	Buck2 Peak Switching Current Limit			2.0	2.4	
$I_q$	Quiescent Current "On"	No load PFM Mode		33		$\mu$ A
		No load PWM Mode (Forced PWM)		2		mA
$R_{DSON(P)}$	Pin-Pin Resistance PFET			200	400	m $\Omega$
$R_{DSON(N)}$	Pin-Pin Resistance NFET			180	400	m $\Omega$
$T_{ON}$	Turn On Time	Start up from shut-down		500		$\mu$ sec
$C_{IN}$	Input Capacitor	Capacitance for stability	10			$\mu$ F
$C_O$	Output Capacitor	Capacitance for stability	10			$\mu$ F

## I/O Electrical Characteristics

Unless otherwise noted: Typical values and limits appearing in normal type apply for  $T_J = 25^\circ\text{C}$ . Limits appearing in **boldface type** apply over the entire junction temperature range for operation,  $T_J = -40^\circ\text{C}$  to  $+125^\circ\text{C}$ .

Symbol	Parameter	Conditions	Limit		Units
			Min	Max	
$V_{IL}$	Input Low Level			<b>0.4</b>	V
$V_{IH}$	Input High Level		<b>0.7*VDD</b>		V

## Power On Reset Threshold/Function (POR)

Symbol	Parameter	Conditions	Min	Typ	Max	Units
nPOR	nPOR = Power on reset for Buck1 and Buck2	Default = 60 mS		60		mS
		Default = 130 $\mu$ S		130		$\mu$ S
nPOR Threshold	Percentage of Target voltage Buck1 or Buck2	$V_{BUCK1}$ AND $V_{BUCK2}$ rising		92		%
		$V_{BUCK1}$ OR $V_{BUCK2}$ falling		82		
$V_{OL}$	Output Level Low	Load = $I_{OL} = 500 \mu$ A		0.23	0.5	V

**Note 1:** Absolute Maximum Ratings indicate limits beyond which damage to the component may occur. Operating Ratings are conditions under which operation of the device is guaranteed. Operating Ratings do not imply guaranteed performance limits. For guaranteed performance limits and associated test conditions, see the Electrical Characteristics.

**Note 2:** All voltages are with respect to the potential at the GND pin.

**Note 3:** Internal thermal shutdown circuitry protects the device from permanent damage. Thermal shutdown engages at  $T_J = 160^\circ\text{C}$  (typ.) and disengages at  $T_J = 140^\circ\text{C}$  (typ.)

**Note 4:** The Human body model is a 100 pF capacitor discharged through a 1.5 k $\Omega$  resistor into each pin. (MILSTD - 883 3015.7)

**Note 5:** In applications where high power dissipation and/or poor package thermal resistance is present, the maximum ambient temperature may have to be derated. Maximum ambient temperature ( $T_{A-MAX}$ ) is dependent on the maximum operating junction temperature ( $T_{J-MAX-OP} = 125^\circ\text{C}$ ), the maximum power dissipation of the device in the application ( $P_{D-MAX}$ ), and the junction-to-ambient thermal resistance of the part/package in the application ( $\theta_{JA}$ ), as given by the following equation:  $T_{A-MAX} = T_{J-MAX-OP} - (\theta_{JA} \times P_{D-MAX})$ . See Applications section.

**Note 6:** Junction-to-ambient thermal resistance is highly application and board-layout dependent. In applications where high maximum power dissipation exists, special care must be paid to thermal dissipation issues in board design.

**Note 7:** Min and Max limits are guaranteed by design, test, or statistical analysis. Typical numbers are not guaranteed, but do represent the most likely norm.

**Note 8:**  $C_{IN}$ ,  $C_{OUT}$ : Low-ESR Surface-Mount Ceramic Capacitors (MLCCs) used in setting electrical characteristics.

**Note 9:** The device maintains a stable, regulated output voltage without a load.

**Note 10:** Dropout voltage is the voltage difference between the input and the output at which the output voltage drops to 100 mV below its nominal value.

**Note 11:** Quiescent current is defined here as the difference in current between the input voltage source and the load at  $V_{OUT}$ .

**Note 12:**  $V_{IN}$  minimum for line regulation values is 1.8V.

**Note 13:** This specification is guaranteed by design.

**Note 14:**  $V_{IN} \geq V_{OUT} + R_{DS(on)(P)} (I_{OUT} + 1/2 I_{RIPPLE})$ . If these conditions are not met, voltage regulation will degrade as load increases.

**Note 15:** Pins 24, 19 can operate from  $V_{IN}$  min of 1.74V to a  $V_{IN}$  max of 5.5V. This rating is only for the series pass PMOS power FET. It allows the system design to use a lower voltage rating if the input voltage comes from a buck output.

**Note 16:** VPOR is voltage at which the EPROM resets. This is different from the UVLO on VINLDO12, which is the voltage at which the regulators shut off; and is also different from the nPOR function, which signals if the regulators are in a specified range.



# Typical Performance Characteristics — LDO

**Output Voltage Change vs Temperature (LDO1)**  
 $V_{IN} = 3.6V, V_{OUT} = 2.5V, 100\text{ mA load}$

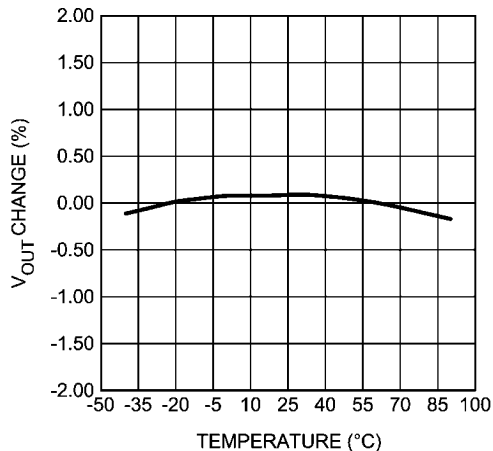

30040466

**Output Voltage Change vs Temperature (LDO2)**  
 $V_{IN} = 3.6V, V_{OUT} = 1.8V, 100\text{ mA load}$

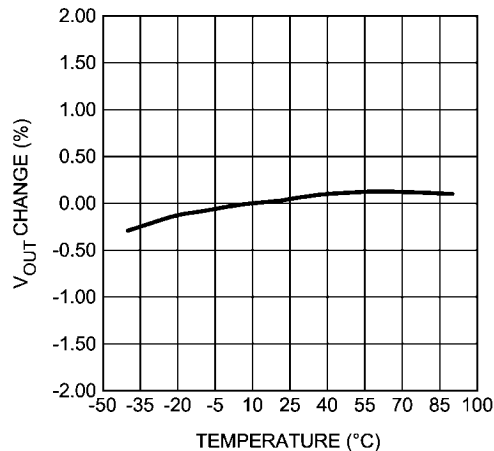

30040455

**Load Transient**  
 $3.6\text{ V}_{IN}, 2.5\text{V}_{OUT}, 0 - 150\text{ mA load}$

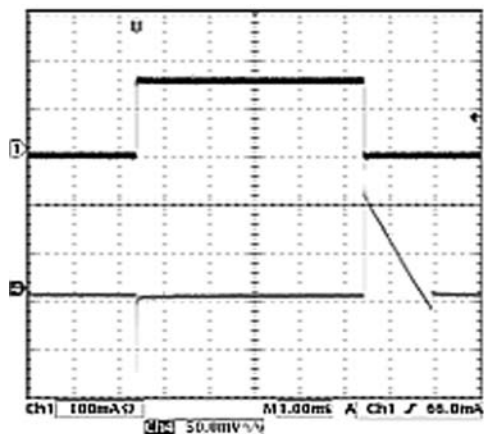

30040437

**Load Transient**  
 $3.6\text{ V}_{IN}, 2.5\text{V}_{OUT}, 150-300\text{ mA load}$

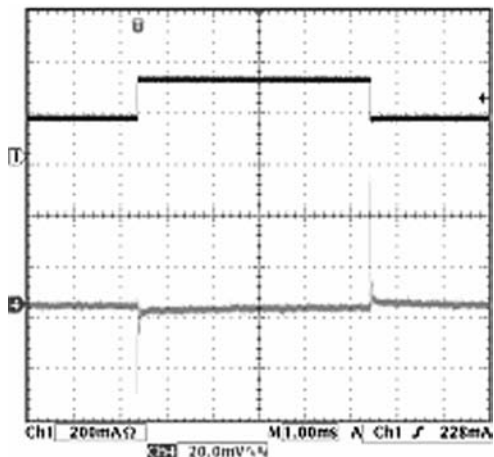

30040438

**Line Transient (LDO1)**  
 $3.6 - 4.2\text{ V}_{IN}, 2.5\text{ V}_{OUT}, 100\text{ mA load}$

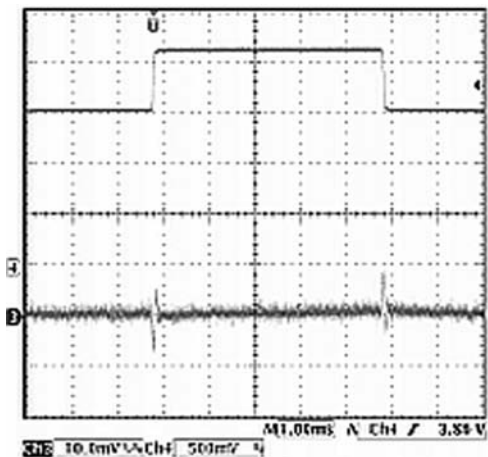

30040439

**Line Transient (LDO2)**  
 $3.6 - 4.2\text{ V}_{IN}, 1.8\text{V}_{OUT}, 150\text{ mA load}$

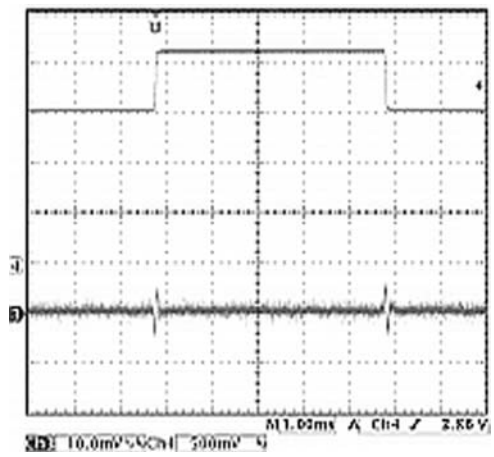

30040440

Enable Start-up time (LDO1)  
 0-3.6 V<sub>IN</sub>, 2.5 V<sub>OUT</sub>, 1 mA load

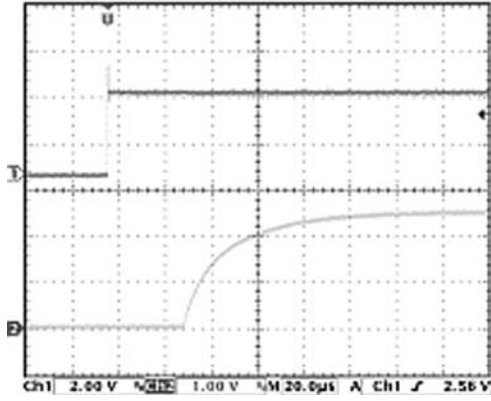

30040441

Enable Start-up time (LDO2)  
 0-3.6 V<sub>IN</sub>, 1.8V<sub>OUT</sub>, 1 mA load

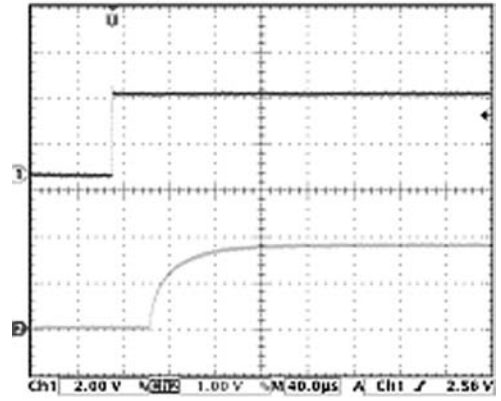

30040442

Typical Performance Characteristics — Buck  $V_{IN} = 2.8V$  to  $5.5V$ ,  $T_A = 25^\circ C$

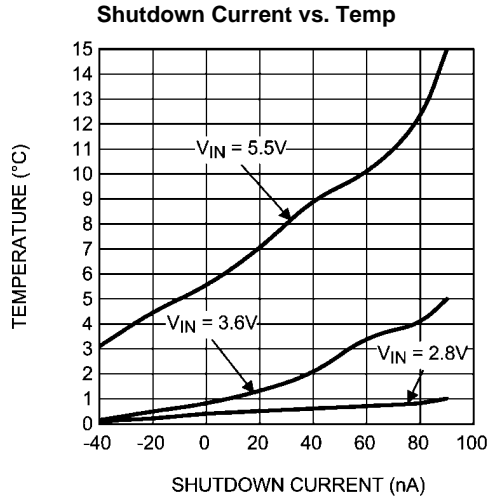

30040443

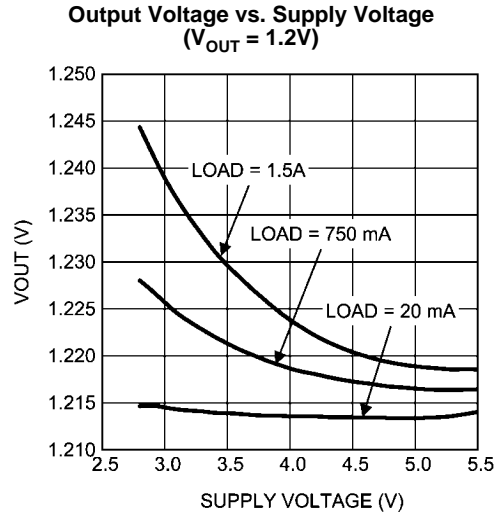

30040444

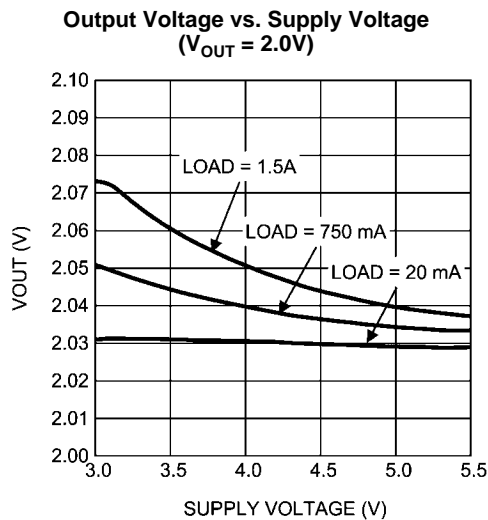

30040445

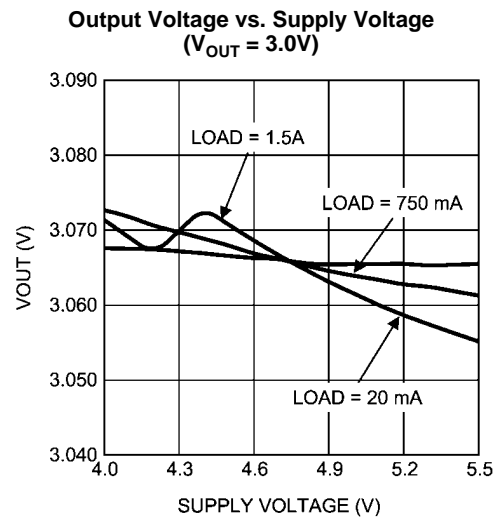

30040446

# Typical Performance Characteristics — Buck

mode for Buck 1

Output Current transitions from PFM mode to PWM

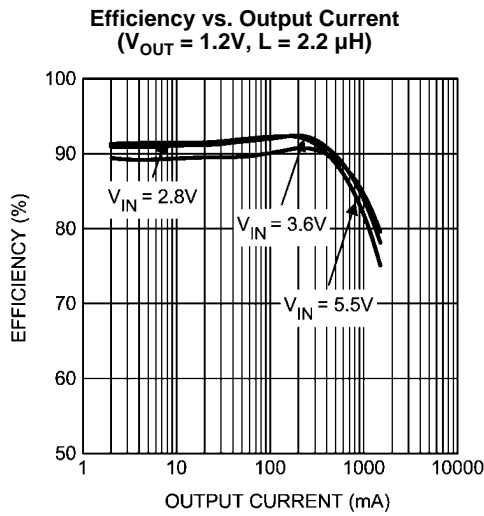

30040447

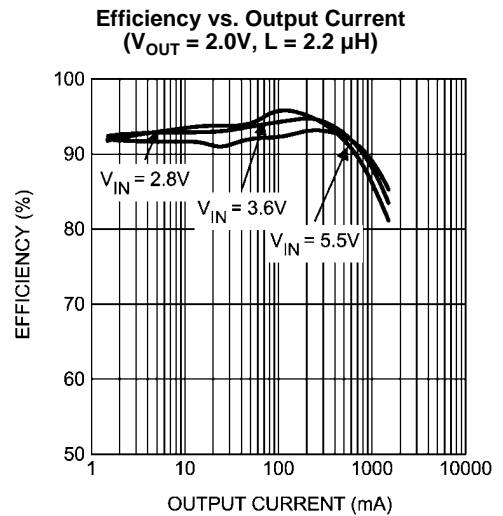

30040448

Output Current transitions from PWM mode to PFM mode for Buck 2

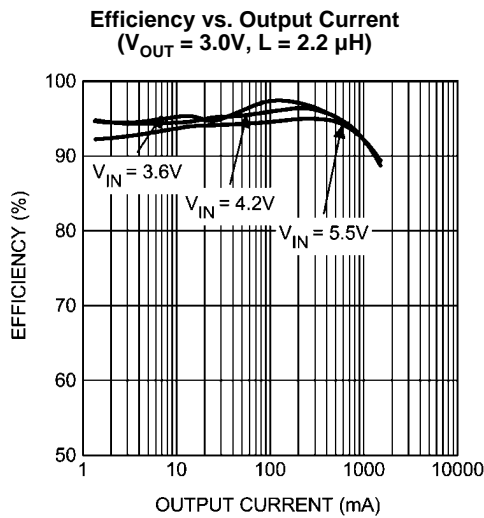

30040449

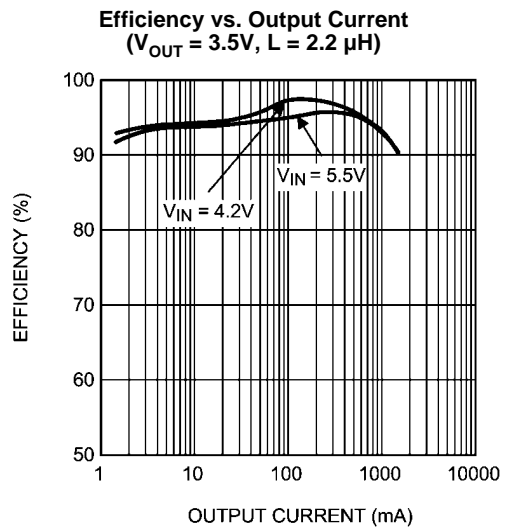

30040450

**Typical Performance Characteristics — Buck**  $V_{IN} = 3.6V, T_A = 25^\circ C, V_{OUT} = 1.2V$  unless otherwise noted

**Load Transient Response**  
 $V_{OUT} = 1.2V$  (PWM Mode)

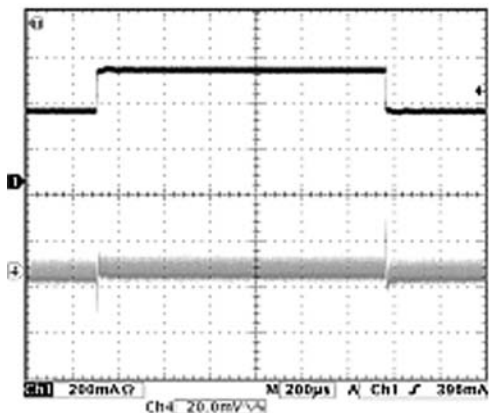

30040456

**Mode Change by Load Transients**  
 $V_{OUT} = 1.2V$  (PWM to PFM)

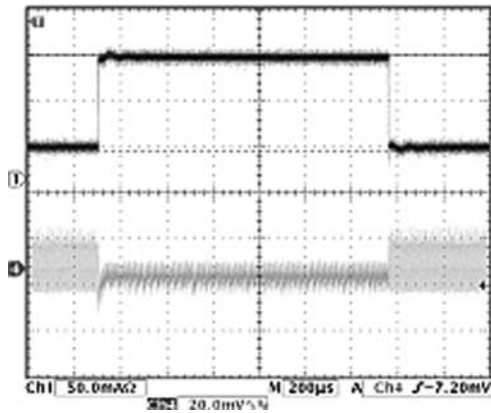

30040457

**Line Transient Response**  
 $V_{IN} = 3.6 - 4.2V, V_{OUT} = 1.2V, 250\text{ mA load}$

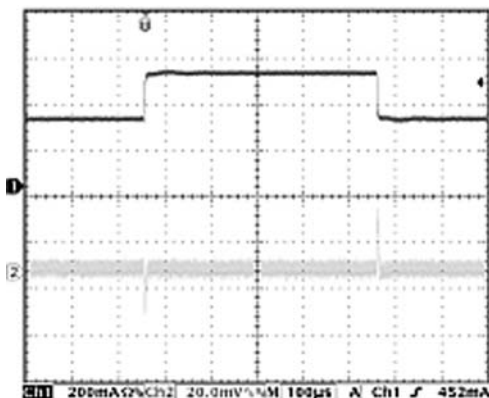

30040458

**Line Transient Response**  
 $V_{IN} = 3.0 - 3.6V, V_{OUT} = 3.0V, 250\text{ mA load}$

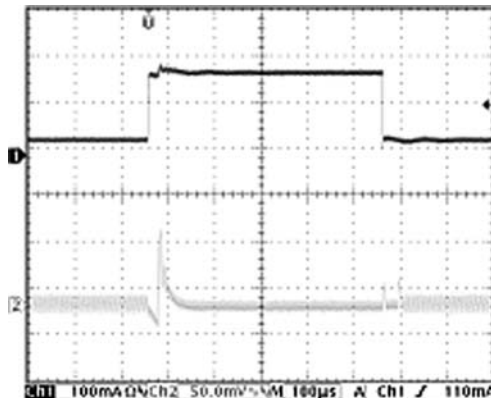

30040459

**Start up into PWM Mode**  
 $V_{OUT} = 1.2V, 1.5A\text{ load}$

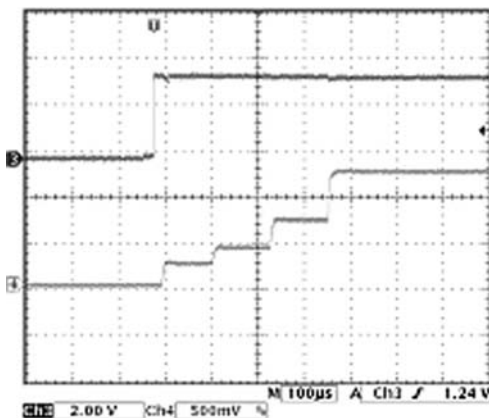

30040460

**Start up into PWM Mode**  
 $V_{OUT} = 3.0\text{ V}, 1.5A\text{ load}$

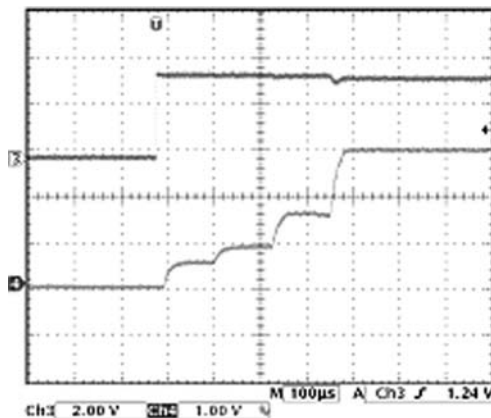

30040461

Start up into PFM Mode  
 $V_{OUT} = 1.2V, 30\text{ mA load}$

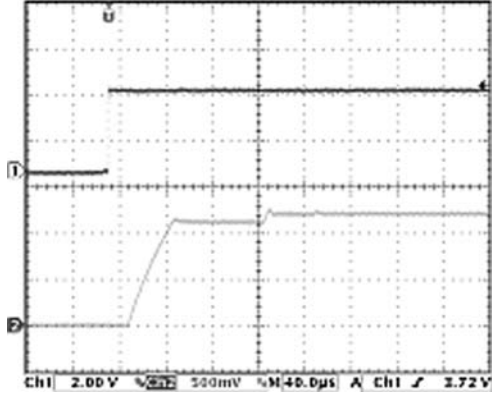

30040462

Start up into PFM Mode  
 $V_{OUT} = 3.0V, 30\text{ mA load}$

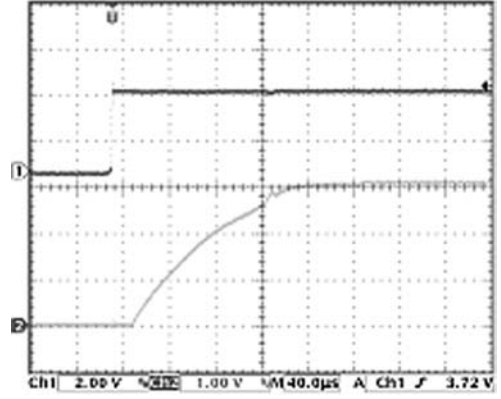

30040470

## DC/DC Converters

### OVERVIEW

The LM26480 provides the DC/DC converters that supply the various power needs of the application by means of two linear low dropout regulators, LDO1 and LDO2, and two buck converters, SW1 and SW2. The table here under lists the output characteristics of the various regulators.

**Supply Specification**

Supply	Load	Output	
		V <sub>OUT</sub> Range (V)	I <sub>MAX</sub> Maximum Output Current (mA)
LDO1	analog	1.0 to 3.5	300
LDO2	analog	1.0 to 3.5	300
SW1	digital	0.8 to 2.0	1500
SW2	digital	1.0 to 3.3	1500

### LINEAR LOW DROPOUT REGULATORS (LDOs)

LDO1 and LDO2 are identical linear regulators targeting analog loads characterized by low noise requirements. LDO1 and LDO2 are enabled through the ENLDO pin.

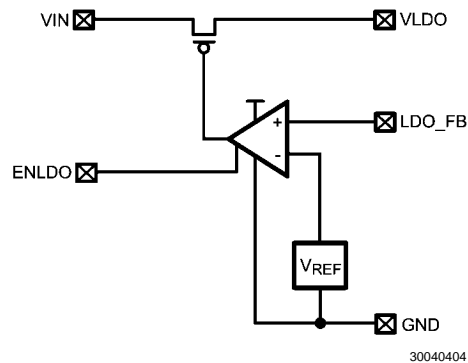

### NO-LOAD STABILITY

The LDOs will remain stable and in regulation with no external load. This is an important consideration in some circuits, for example, CMOS RAM keep-alive applications.

## SW1, SW2: Synchronous Step-Down Magnetic DC/DC Converters

### FUNCTIONAL DESCRIPTION

The LM26480 incorporates two high-efficiency synchronous switching buck regulators, SW1 and SW2, that deliver a constant voltage from a single Li-Ion battery to the portable system processors. Using a voltage mode architecture with synchronous rectification, both bucks have the ability to deliver up to 1500 mA depending on the input voltage and output voltage (voltage head room), and the inductor chosen (maximum current capability).

There are three modes of operation depending on the current required - PWM, PFM, and shutdown. PWM mode handles current loads of approximately 70 mA or higher, delivering voltage precision of +/-3% with 90% efficiency or better. Lighter output current loads cause the device to automatically switch into PFM for reduced current consumption ( $I_Q = 33 \mu\text{A}$  typ.) and a longer battery life. The Standby operating mode turns off the device, offering the lowest current consumption. PWM or PFM mode is selected automatically or PWM mode can be forced through the setting of the buck control register.

Both SW1 and SW2 can operate up to a 100% duty cycle (PMOS switch always on) for low drop out control of the output voltage. In this way the output voltage will be controlled down to the lowest possible input voltage.

Additional features include soft-start, under-voltage lock-out, current overload protection, and thermal overload protection.

### CIRCUIT OPERATION DESCRIPTION

A buck converter contains a control block, a switching PFET connected between input and output, a synchronous rectifying NFET connected between the output and ground (BCKGND pin) and a feedback path. During the first portion of each switching cycle, the control block turns on the internal PFET switch. This allows current to flow from the input through the inductor to the output filter capacitor and load. The inductor limits the current to a ramp with a slope of

$$\frac{V_{IN} - V_{OUT}}{L}$$

by storing energy in a magnetic field. During the second portion of each cycle, the control block turns the PFET switch off, blocking current flow from the input, and then turns the NFET synchronous rectifier on. The inductor draws current from ground through the NFET to the output filter capacitor and load, which ramps the inductor current down with a slope of

$$\frac{-V_{OUT}}{L}$$

The output filter stores charge when the inductor current is high, and releases it when low, smoothing the voltage across the load.

### SYNC FUNCTION

The LM26480SQ-BF is the only version of the part that has the ability to use an external oscillator. The source must be 13 MHz nominal and operate within a range of 15.6 MHz and 10.4 MHz, proportionally the same limits as the 2.0 MHz internal oscillator. The LM26480SQ-BF has an internal divider which will divide the speed down by 6.5 to the nominal 2MHz and use it for the regulators. This SYNC function replaces the internal oscillator and works in forced PWM only. The buck regulators no longer have the PFM function enabled. When the LM26480SQ-BF is sold with this feature enabled, the part will not function without the external oscillator present. Please contact Texas Instruments Sales Office/Distributors for availability of LM26480SQ-BF.

### PWM OPERATION

During PWM operation the converter operates as a voltage-mode controller with input voltage feed forward. This allows the converter to achieve excellent load and line regulation. The DC gain of the power stage is proportional to the input voltage. To eliminate this dependence, feed forward voltage inversely proportional to the input voltage is introduced.

### INTERNAL SYNCHRONOUS RECTIFICATION

While in PWM mode, the buck uses an internal NFET as a synchronous rectifier to reduce rectifier forward voltage drop and associated power loss. Synchronous rectification provides a significant improvement in efficiency whenever the output voltage is relatively low compared to the voltage drop across an ordinary rectifier diode.

### CURRENT LIMITING

A current limit feature allows the converter to protect itself and external components during overload conditions. PWM mode implements current limiting using an internal comparator that trips at 2.0A for both bucks (typ). If the output is shorted to ground the device enters a timed current limit mode where the NFET is turned on for a longer duration until the inductor current falls below a low threshold, ensuring inductor current has more time to decay, thereby preventing runaway.

### PFM OPERATION

At very light loads, the converter enters PFM mode and operates with reduced switching frequency and supply current to maintain high efficiency.

The part will automatically transition into PFM mode when either of two conditions occurs for a duration of 32 or more clock cycles:

- A. The inductor current becomes discontinuous

or

- B. The peak PMOS switch current drops below the  $I_{MODE}$  level

$$\left( \text{Typically } I_{MODE} < 66 \text{ mA} + \frac{V_{IN}}{160\Omega} \right)$$

During PFM operation, the converter positions the output voltage slightly higher than the nominal output voltage during PWM operation, allowing additional headroom for voltage drop during a load transient from light to heavy load. The PFM comparators sense the output voltage via the feedback pin and control the switching of the output FETs such that the output voltage ramps between 0.8% and 1.6% (typical) above the nominal PWM output voltage. If the output voltage is below the 'high' PFM comparator threshold, the PMOS power switch is turned on. It remains on until the output voltage exceeds the 'high' PFM threshold or the peak current exceeds the  $I_{PFM}$  level set for PFM mode. The typical peak current in PFM mode is:

$$I_{PFM} = 66 \text{ mA} + \frac{V_{IN}}{80\Omega}$$



Once the PMOS power switch is turned off, the NMOS power switch is turned on until the inductor current ramps to zero. When the NMOS zero-current condition is detected, the NMOS power switch is turned off. If the output voltage is below the 'high' PFM comparator threshold (see following figure), the PMOS switch is again turned on and the cycle is repeated until the output reaches the desired level. Once the output reaches the 'high' PFM threshold, the NMOS switch is turned on briefly to ramp the inductor current to zero and then both output switches are turned off and the part enters an extremely low power mode. Quiescent supply current during this 'sleep' mode is less than 30  $\mu\text{A}$ , which allows the part to achieve high efficiencies under extremely light load conditions. When the output drops below the 'low' PFM threshold, the cycle repeats to restore the output voltage to  $\sim 1.6\%$  above the nominal PWM output voltage.

If the load current should increase during PFM mode (see figure below) causing the output voltage to fall below the 'low2' PFM threshold, the part will automatically transition into fixed-frequency PWM mode.

### SW1, SW2 CONTROL

SW1 and SW2 are enabled/disabled through the external enable pins.

The Modulation mode PWM/PFM is by default automatic and depends on the load as described above in the functional description. The modulation mode can be factory trimmed, forcing the buck to operate in PWM mode regardless of the load condition.

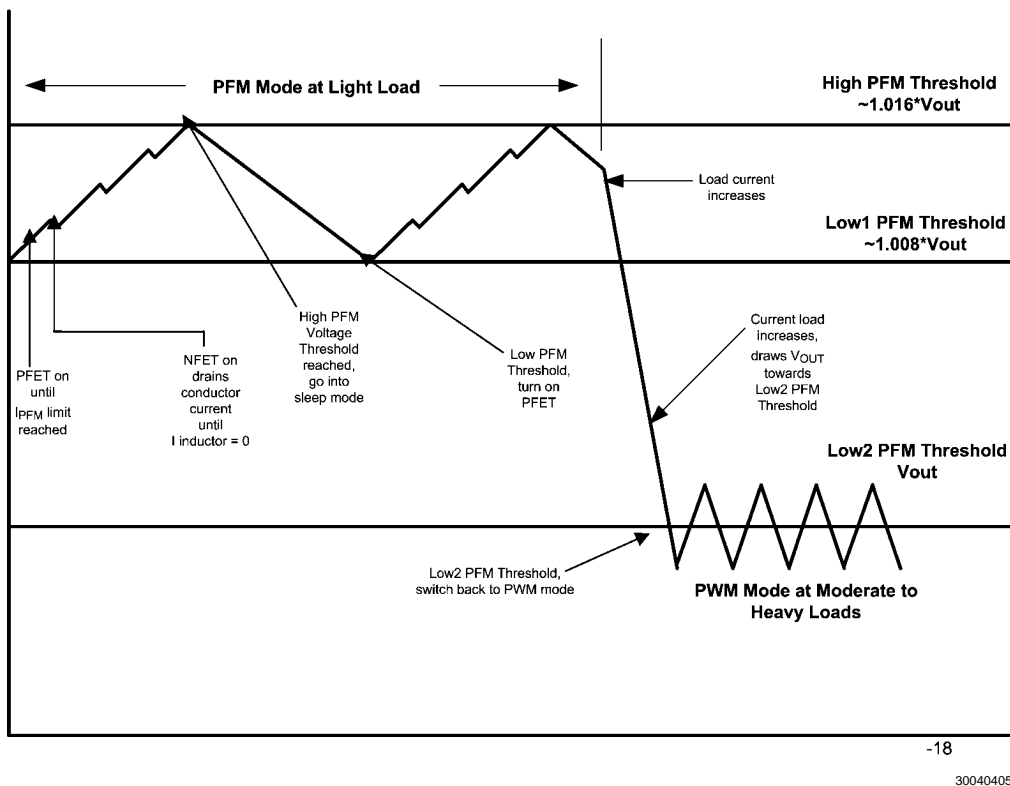

### SHUTDOWN MODE

During shutdown the PFET switch, reference, control and bias circuitry of the converters are turned off. The NFET switch will be on in shutdown to discharge the output. When the converter is enabled, soft start is activated. It is recommended to disable the converter during the system power up and under voltage conditions when the supply is less than 2.8V.

### SOFT START

The soft-start feature allows the power converter to gradually reach the initial steady state operating point, thus reducing startup stresses and surges. The two LM26480 buck converters have a soft-start circuit that limits in-rush current during startup. During startup the switch current limit is increased in steps. Soft start is activated only if EN goes from logic low to logic high after  $V_{IN}$  reaches 2.8V. Soft start is implemented by increasing switch current limit in steps of 250 mA, 500 mA, 950 mA and 2A for both bucks (typ. switch current limit). The startup time thereby depends on the output capacitor and load current demanded at start-up.

### LOW DROPOUT OPERATION

The LM26480 can operate at 100% duty cycle (no switching; PMOS switch completely on) for low dropout support of the output voltage. In this way the output voltage will be controlled down to the lowest possible input voltage. When the device operates near 100% duty cycle, output voltage ripple is approximately 25 mV. The minimum input voltage needed to support the output voltage is

$$V_{IN, MIN} = I_{LOAD} * (R_{DSON, PFET} + R_{INDUCTOR}) + V_{OUT}$$

- $I_{LOAD}$  Load current
- $R_{DSON, PFET}$  Drain to source resistance of PFET switch in the triode region
- $R_{INDUCTOR}$  Inductor resistance

**FLEXIBLE POWER-ON RESET (i.e., POWER GOOD WITH DELAY)**

The LM26480 is equipped with an internal Power-On-Reset (“POR”) circuit which monitors the output voltage levels on bucks 1 and 2. The nPOR is an open drain logic output which is logic LOW when either of the buck outputs are below 92% of the rising value, or when one or both outputs fall below 82% of the desired value. The time delay between output voltage level and nPOR is enabled is (130  $\mu$ s, 60 ms, 100 ms, 200 ms), 60 ms by default. For any other delay option, other than the default, please consult a Texas Instruments Sales Representative. The system designer can choose the external pull-up resistor (i.e. 100 k $\Omega$  ) for the nPOR pin.

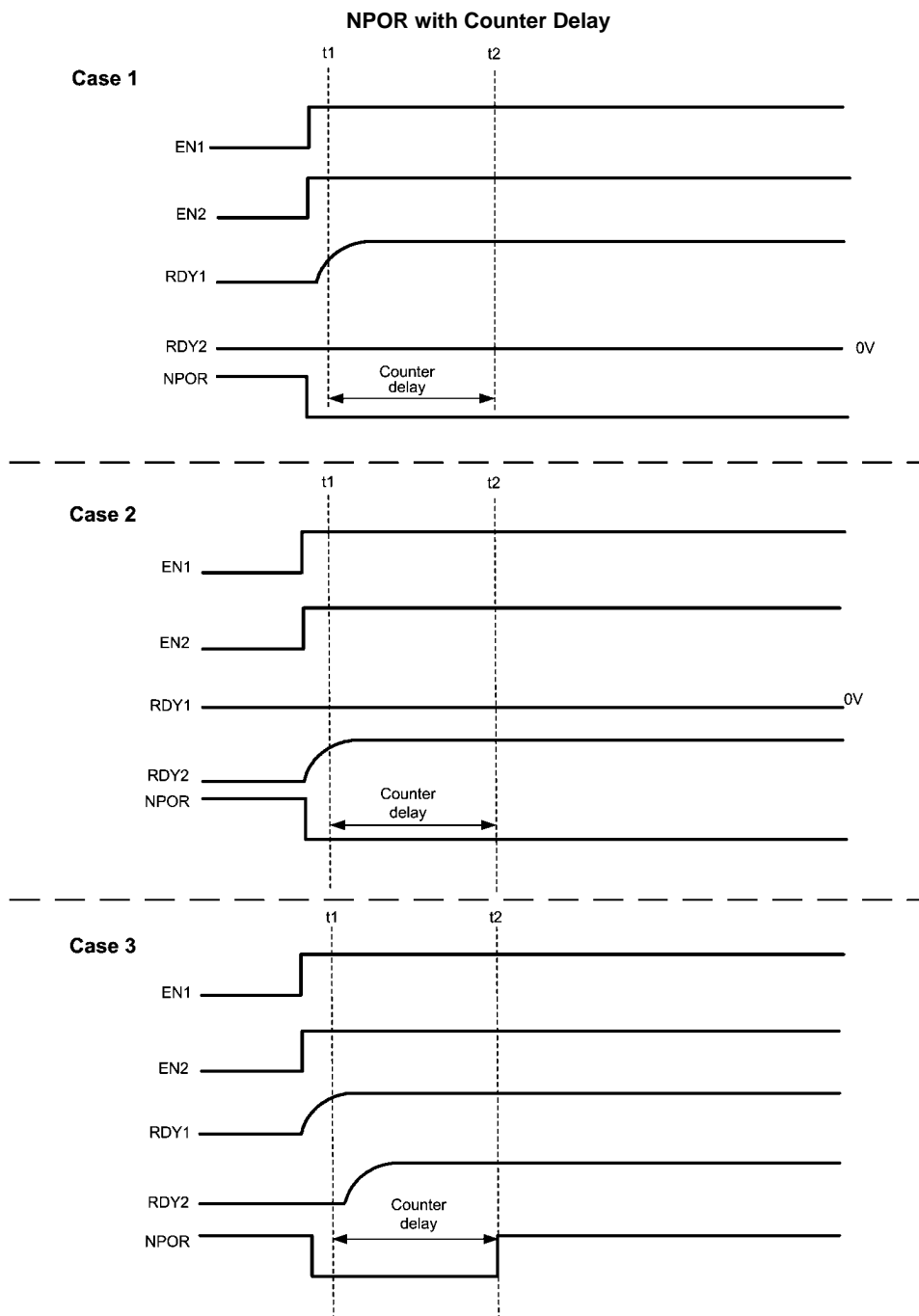

30040406

The above diagram shows the simplest application of the Power-On Reset, where both switcher enables are tied together. In Case 1, EN1 causes nPOR to transition LOW and triggers the nPOR delay counter. If the power supply for Buck2 does not come on within that period, nPOR will stay LOW, indicating a power fail mode. Case 2 indicates the vice versa scenario if Buck1 supply did not come on. In both cases the nPOR remains LOW. Case 3 shows a typical application of the Power-On Reset, where both switcher enables are tied together. Even if RDY1 ramps up slightly faster than RDY2 (or vice versa), the nPOR signal will trigger a programmable delay before going HIGH, as explained below.

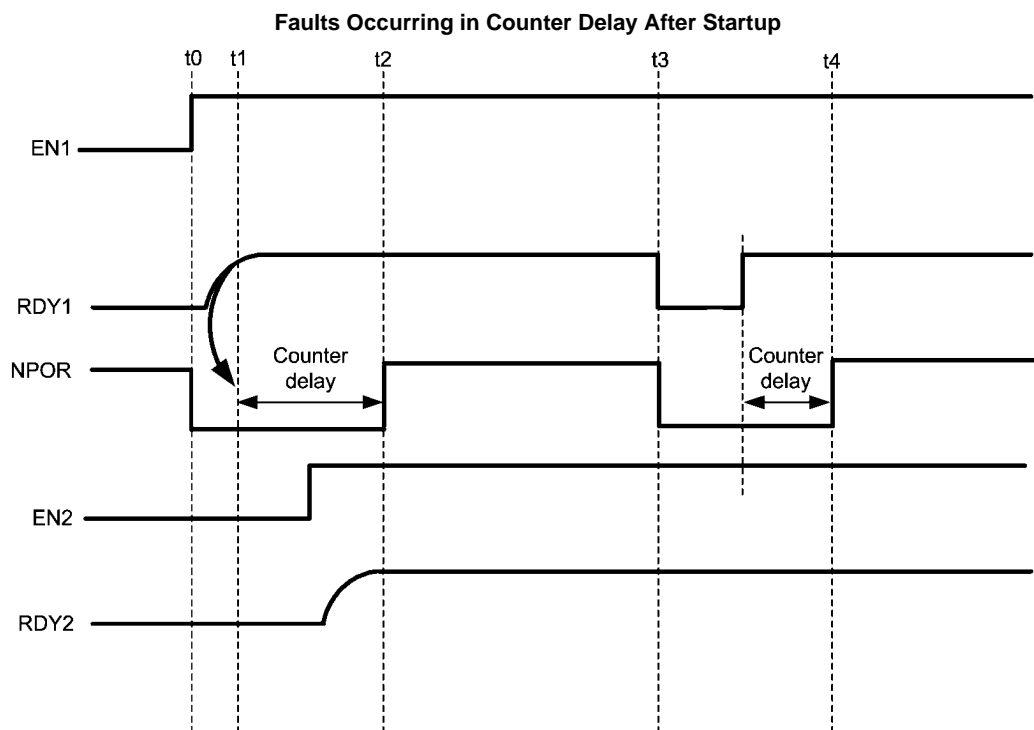

30040407

The above timing diagram details the Power Good with delay with respect to the enable signals EN1, and EN2. The RDY1, RDY2 are internal signals derived from the output of two comparators. Each comparator has been trimmed as follows:

Comparator Level	Buck Supply Level
HIGH	Greater than 92%
LOW	Less than 82%

The circuits for EN1 and RDY1 are symmetrical to EN2 and RDY2, so each reference to EN1 and RDY1 will also work for EN2 and RDY2 and vice versa.

If EN1 and RDY1 signals are High at time t1, then the RDY1 signal rising edge triggers the programmable delay counter (130  $\mu$ s, 60 ms, 100 ms, 200 ms). This delay forces nPOR LOW between time interval t1 and t2. NPOR is then pulled high after the programmable delay is completed. Now if EN2 and RDY2 are initiated during this interval the nPOR signal ignores this event.

If either RDY1 or RDY2 were to go LOW at t3 then the programmable delay is triggered again.

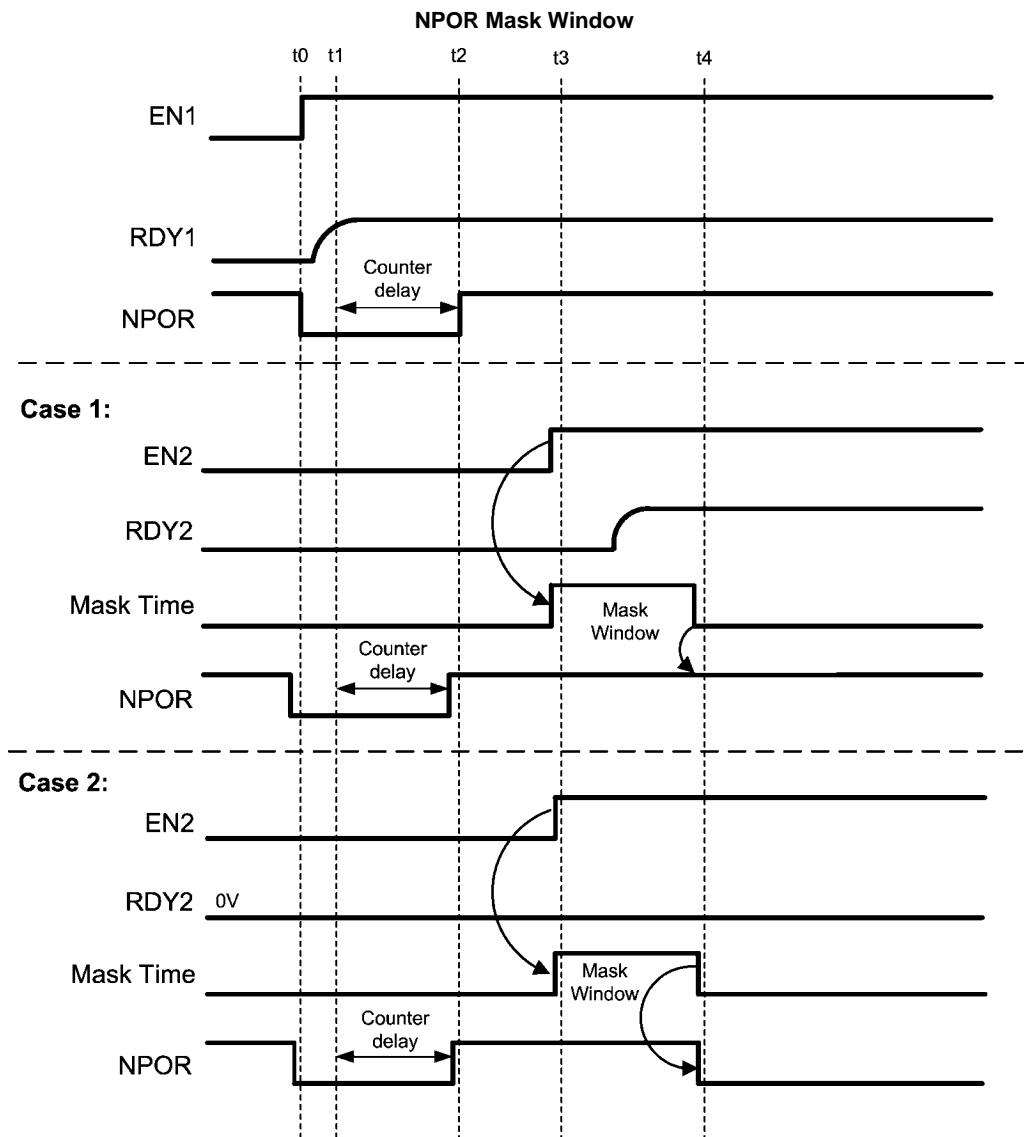

30040408

In Case 1, we see that case where EN2 and RDY2 are initiated after triggered programmable delay. To prevent the nPOR being asserted again, a masked window (5 ms) counter delay is triggered off the EN2 rising edge. NPOR is still held HIGH for the duration of the mask, whereupon the nPOR status afterwards will depend on the status of both RDY1 and RDY2 lines.

In Case 2, we see the case where EN2 is initiated after the RDY1 triggered programmable delay, but RDY2 never goes HIGH (Buck2 never turns on). Normal operation operation of nPOR occurs with respect to EN1 and RDY1, and the nPOR signal is held HIGH for the duration of the mask window. We see that nPOR goes LOW after the masking window has timed out because it is now dependent on RDY1 and RDY2, where RDY2 is LOW.

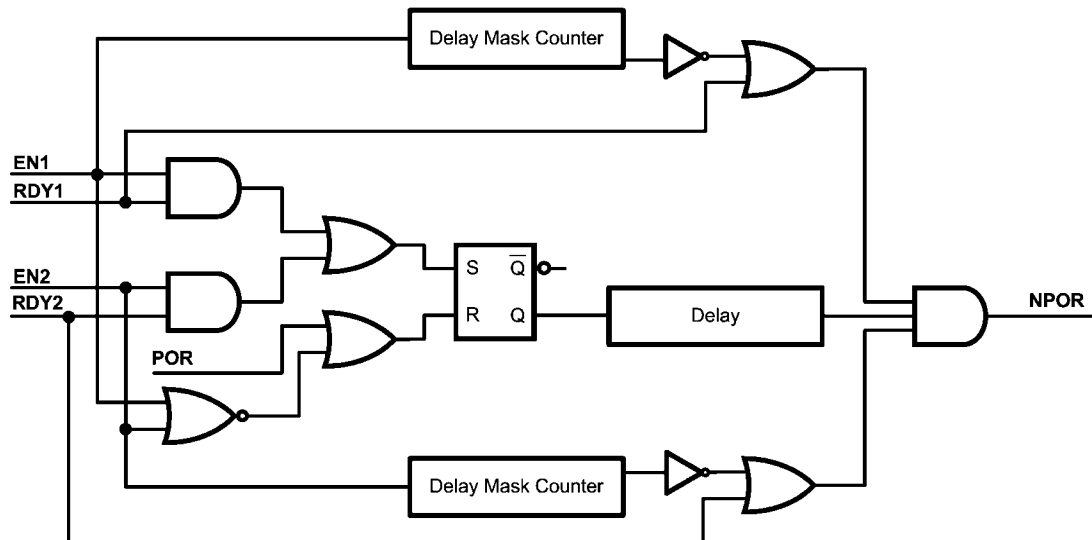
**Design Implementation of the Flexible Power-On Reset**

30040409

Design implementation of the flexible power-on reset. An internal power-on reset of the IC is used with EN1 and EN2 to produce a reset signal (LOW) to the delay timer nPOR. EN1 and RDY1 or EN2 and RDY2 are used to generate the set signal (HIGH) to the delay timer. S=R=1 never occurs. The mask timers are triggered off EN1 and EN2 which are gated with RDY1, and RDY2 to generate outputs to the final AND gate to generate the nPOR.

**UNDER VOLTAGE LOCK OUT**

The LM26480 features an "under voltage lock out circuit". The function of this circuit is to continuously monitor the raw input supply voltage (VINLDO12) and automatically disables the four voltage regulators whenever this supply voltage is less than 2.8 VDC.

The circuit incorporates a bandgap based circuit that establishes the reference used to determine the 2.8 VDC trip point for a  $V_{IN}$  OK – Not OK detector. This  $V_{IN}$  OK signal is then used to gate the enable signals to the four regulators of the LM26480. When VINLDO12 is greater than 2.8 VDC the four **enables** control the four regulators, when VINLDO12 is less than 2.8 VDC the four regulators are **disabled** by the  $V_{IN}$  detector being in the "Not OK" state. The circuit has built in hysteresis to prevent chattering occurring.

## Application Notes

### EXTERNAL COMPONENT SELECTION

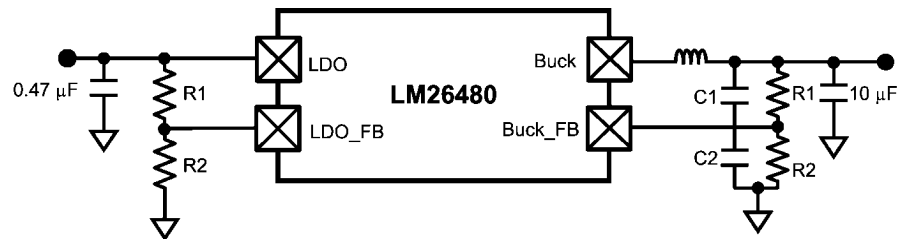

30040410

Target Vout (V)	Ideal Resistor Values		Common R Values		Actual VOUT W/ Com/R (V)	Actual VOUT Delta from Target (V)	Feedback Capacitors		
	R1 (KΩ)	R2 (KΩ)	R1 (KΩ)	R2 (KΩ)			C1(pF)	C2(pF)	
0.8	120	200	121	200	0.803	0.002	15	none	Buck1
0.9	160	200	162	200	0.905	0.005	15	none	Only
1	200	200	200	200	1	0	15	none	^
1.1	240	200	240	200	1.1	0	15	none	
1.2	280	200	280	200	1.2	0	12	none	
1.3	320	200	324	200	1.31	0.01	12	none	Buck1
1.4	360	200	357	200	1.393	-0.008	10	none	And
1.5	400	200	402	200	1.505	0.005	10	none	Buck2
1.6	440	200	442	200	1.605	0.005	8.2	none	
1.7	427	178	432	178	1.713	0.013	8.2	none	
1.8	463	178	464	178	1.803	0.003	8.2	none	
1.9	498	178	499	178	1.902	0.002	8.2	none	
2	450	150	453	150	2.01	0.01	8.2	none	>
2.1	480	150	475	150	2.083	-0.017	8.2	none	^
2.2	422	124	422	124	2.202	0.002	8.2	none	
2.3	446	124	442	124	2.282	-0.018	8.2	none	
2.4	471	124	475	124	2.415	0.015	8.2	none	
2.5	400	100	402	100	2.51	0.01	8.2	none	
2.6	420	100	422	100	2.61	0.01	8.2	none	
2.7	440	100	442	100	2.71	0.01	8.2	33	Buck2
2.8	460	100	464	100	2.82	0.02	8.2	33	Only
2.9	480	100	475	100	2.875	-0.025	8.2	33	
3	500	100	499	100	2.995	-0.005	6.8	33	
3.1	520	100	523	100	3.115	0.015	6.8	33	
3.2	540	100	536	100	3.18	-0.02	6.8	33	
3.3	560	100	562	100	3.31	0.01	6.8	33	

The output voltages of the bucks of the LM26480 are established by the feedback resistor dividers R1 and R2 shown on the application circuit above. The equation for determining V is:  $V_{OUT} = V_{FB} (R1+R2)/R2$  where  $V_{FB}$  is the voltage on the Buck FBx pin. The Buck control loop will force the voltage on  $V_{FB}$  to be  $0.50 V \pm 3\%$ .

The above table shows ideal resistor values to establish buck voltages from 0.8V to 3.3 V along with common resistor values to establish these voltages. Common resistors do not always produce the target value, error is given in the delta column.

In addition to the resistor feedback, capacitor feedback C1 is always required, and depending on the output voltage capacitor C2 is also required. See the application diagram below and the above table for these requirements.

Inductor	Value	Unit	Description	Notes
$L_{SW1,2}$	2.2	μH	SW1,2 inductor	D.C.R. 70 mΩ

## OUTPUT INDUCTORS & CAPACITORS FOR SW1 AND SW2

There are several design considerations related to the selection of output inductors and capacitors:

- Load transient response;
- Stability;
- Efficiency;
- Output ripple voltage; and
- Over-current ruggedness.

The LM26480 has been optimized for use with nominal values 2.2  $\mu$ H and 10  $\mu$ F. If other values are needed for the design, please contact Texas Instruments sales with any concerns.

### INDUCTOR SELECTION FOR SW1 AND SW2

A nominal inductor value of 2.2  $\mu$ H is recommended. It is important to guarantee the inductor core does not saturate during any foreseeable operational situation.

Care should be taken when reviewing the different saturation current ratings that are specified by different manufacturers. Saturation current ratings are typically specified at 25°C, so ratings at maximum ambient temperature of the application should be requested from the manufacturer.

There are two methods to choose the inductor saturation current rating:

#### Recommended method:

The best way to guarantee the inductor does not saturate is to choose an inductor that has saturation current rating greater than the maximum LM26480 current limit of 2.4A. In this case the device will prevent inductor saturation.

#### Alternate method:

If the recommended approach cannot be used, care must be taken to guarantee that the saturation current is greater than the peak inductor current:

$$I_{SAT} > I_{LPEAK}$$

$$I_{LPEAK} = I_{OUTMAX} + \frac{I_{RIPPLE}}{2}$$

$$I_{RIPPLE} = \frac{D \times (V_{IN} - V_{OUT})}{L \times F}$$

$$D = \frac{V_{OUT}}{V_{IN} \times EFF}$$

30040471

$I_{SAT}$ :	Inductor saturation current at operating temperature
$I_{LPEAK}$ :	Peak inductor current during worst case conditions
$I_{OUTMAX}$ :	Maximum average inductor current
$I_{RIPPLE}$ :	Peak-to-Peak inductor current
$V_{OUT}$ :	Output voltage
$V_{IN}$ :	Input voltage
L:	Inductor value in Henries at $I_{OUTMAX}$
F:	Switching frequency, Hertz
D:	Estimated duty factor
EFF:	Estimated power supply efficiency

$I_{SAT}$  may not be exceeded during any operation, including transients, startup, high temperature, worst case conditions, etc.

### SUGGESTED INDUCTORS AND THEIR SUPPLIERS

Model	Vendor	Dimensions (mm)	DCR (max)	$I_{SATURATION}$
DO3314-222MX	Coilcraft	3.3 x 3.3 x 1.4	200 m $\Omega$	$\approx$ 1.8A
LPO3310-222MX	Coilcraft	3.3 x 3.3 x 1	150 m $\Omega$	$\approx$ 1.3A
ELL6PG2R2N	Panasonic	6.0 x 6.0 x 2.0	37 m $\Omega$	$\approx$ 2.2A
ELC6GN2R2N	Panasonic	6.0 x 6.0 x 1.5	53 m $\Omega$	$\approx$ 1.9A
CDRH2D14NP-2R2NC	Sumida	3.2 x 3.2 x 1.5	94 m $\Omega$	$\approx$ 1.5A

Note: Inductor Current Saturation values are estimates; inductor manufacturer should be contacted for guaranteed values.

### OUTPUT CAPACITOR SELECTION FOR SW1 AND SW2

A ceramic output capacitor of 10  $\mu$ F, 6.3V is recommended with an ESR of less than 500 m $\Omega$ .

Output ripple can be estimated from the vector sum of the reactive (Capacitor) voltage component and the real (ESR) voltage component of the output capacitor.

$$V_{\text{COUT}} = \frac{I_{\text{RIPPLE}}}{8 \times F \times C_{\text{OUT}}}$$

$$V_{\text{ROUT}} = I_{\text{RIPPLE}} \times \text{ESR}_{\text{COUT}}$$

$$V_{\text{PPOUT}} = \sqrt{V_{\text{COUT}}^2 + V_{\text{ROUT}}^2}$$

$V_{\text{COUT}}$ : Estimated reactive output ripple  
 $V_{\text{ROUT}}$ : Estimated real output ripple  
 $V_{\text{PPOUT}}$ : Estimated peak-to-peak output ripple

The output capacitor needs to be mounted as close as possible to the output pin of the device. For better temperature performance, X7R or X5R types are recommended. DC bias characteristics of ceramic capacitors must be considered when selecting case sizes like 0805 and 0603.

DC bias characteristics vary from manufacturer to manufacturer and by case size. DC bias curves should be requested from them as part of the capacitor selection process. ESR is typically higher for smaller packages.

The output filter capacitor smooths out current flow from the inductor to the load, helps maintain a steady output voltage during transient load changes and reduces output voltage ripple. These capacitors must be selected with sufficient capacitance and sufficiently low ESR to perform these functions.

Note that the output voltage ripple is dependent on the inductor current ripple and the equivalent series resistance of the output capacitor ( $\text{ESR}_{\text{COUT}}$ ).  $\text{ESR}_{\text{COUT}}$  is frequency dependent as well as temperature dependent. The  $R_{\text{ESR}}$  should be calculated with the applicable switching frequency and ambient temperature.

#### INPUT CAPACITOR SELECTION FOR SW1 AND SW2

It is required to use a ceramic input capacitor of at least 4.7  $\mu\text{F}$  and 6.3V with an ESR of less than 500 m $\Omega$ .

The input power source supplies average current continuously. During the PFET switch on-time, however, the demanded di/dt is higher than can be typically supplied by the input power source. This delta is supplied by the input capacitor.

A simplified "worst case" assumption is that all of the PFET current is supplied by the input capacitor. This will result in conservative estimates of input ripple voltage and capacitor RMS current. Input ripple voltage is estimated as follows:

$$V_{\text{PPIN}} = \frac{I_{\text{OUT}} \times D}{C_{\text{IN}} \times F} + I_{\text{OUT}} \times \text{ESR}_{\text{CIN}}$$

$V_{\text{PPIN}}$ : Estimated peak-to-peak input ripple voltage  
 $I_{\text{OUT}}$ : Output current, Amps  
 $C_{\text{IN}}$ : Input capacitor value, Farads  
 $\text{ESR}_{\text{CIN}}$ : Input capacitor ESR, Ohms

This capacitor is exposed to significant RMS current, so it is important to select a capacitor with an adequate RMS current rating. Capacitor RMS current estimated as follows:

$$I_{\text{RMSCIN}} = \sqrt{D \times \left( I_{\text{OUT}}^2 + \frac{I_{\text{RIPPLE}}^2}{12} \right)}$$

$I_{\text{RSCIN}}$  Estimated input capacitor RMS current

Model	Type	Vendor	Voltage Rating	Case Size
<b>4.7 <math>\mu\text{F}</math> for CIN</b>				
C2012X5R0J475K	Ceramic, X5R	TDK	6.3V	0805, (2012)
JMK212BJ475K	Ceramic, X5R	Taiyo-Yuden	6.3V	0805, (2012)
GRM21BR60J475K	Ceramic, X5R	Murata	6.3V	0805, (2012)
C1608X5R0J475K	Ceramic, X5R	TDK	6.3V	0603, (1608)
<b>10 <math>\mu\text{F}</math> for COUT</b>				
GRM21BR60J106K	Ceramic, X5R	Murata	6.3V	0805, (2012)
JMK212BJ106K	Ceramic, X5R	Taiyo-Yuden	6.3V	0805, (2012)
C2012X5R0J106K	Ceramic, X5R	TDK	6.3V	0805, (2012)
C1608X5R0J106K	Ceramic, X5R	TDK	6.3V	0603, (1608)

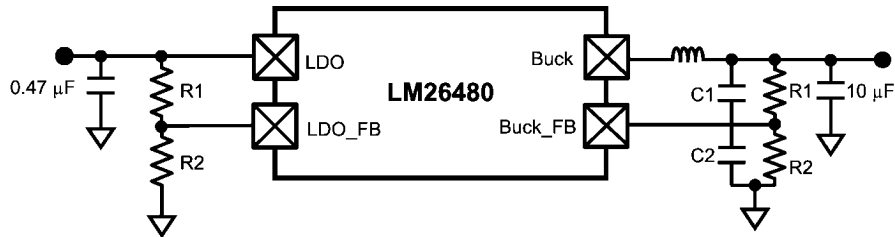

**FEEDBACK RESISTORS FOR LDOs**

30040410

Target V <sub>OUT</sub> (V)	Ideal Resistor Values		Common R Values		Actual V <sub>OUT</sub> W/ Com/R (V)
	R1 (KΩ)	R2 (KΩ)	R1 (KΩ)	R2 (KΩ)	
1	200	200	200	200	1
1.1	240	200	240	200	1.1
1.2	280	200	280	200	1.2
1.3	320	200	324	200	1.31
1.4	360	200	357	200	1.393
1.5	400	200	402	200	1.505
1.6	440	200	442	200	1.605
1.7	480	200	562	232	1.711
1.8	520	200	604	232	1.802
1.9	560	200	562	200	1.905
2	600	200	604	200	2.01
2.1	640	200	715	221	2.118
2.2	680	200	681	200	2.203
2.3	720	200	806	226	2.283
2.4	760	200	845	221	2.412
2.5	800	200	750	187	2.505
2.6	840	200	909	215	2.614
2.7	880	200	1100	249	2.709
2.8	920	200	1150	249	2.809
2.9	960	200	1210	255	2.873
3	1000	200	1000	200	3
3.1	1040	200	1000	191	3.118
3.2	1080	200	1000	187	3.174
3.3	1120	200	1210	215	3.314
3.4	1160	200	1210	210	3.381
3.5	1200	200	1210	200	3.525

The output voltages of the LDOs of the LM26480 are established by the feedback resistor dividers R1 and R2 shown on the application circuit above. The equation for determining V<sub>OUT</sub> is:  $V_{OUT} = V_{FB}(R1+R2)/R2$ , where V<sub>FB</sub> is the voltage on the LDOX\_FB pin.

The LDO control loop will force the voltage on V<sub>FB</sub> to be 0.50 V ±3%. The above table shows ideal resistor values to establish LDO voltages from 1.0V to 3.5V along with common resistor values to establish these voltages. Common resistors do not always produce the target value, error is given in the final column.

To keep the power consumed by the feedback network low it is recommended that R2 be established as about 200 KΩ. Lesser values of R2 are OK at the users discretion..

## LDO CAPACITOR SELECTION

### Input Capacitor

An input capacitor is required for stability. It is recommended that a 1.0  $\mu\text{F}$  capacitor be connected between the LDO input pin and ground (this capacitance value may be increased without limit). This capacitor must be located a distance of not more than 1 cm from the input pin and returned to a clean analog ground. Any good quality ceramic, tantalum, or film capacitor may be used at the input.

**Warning: Important:** Tantalum capacitors can suffer catastrophic failures due to surge currents when connected to a low impedance source of power (like a battery or a very large capacitor). If a tantalum capacitor is used at the input, it must be guaranteed by the manufacturer to have a surge current rating sufficient for the application.

There are no requirements for the ESR on the input capacitor, but tolerance and temperature coefficient must be considered when selecting the capacitor to ensure the capacitance will remain approximately 1.0  $\mu\text{F}$  over the entire operating temperature range.

### Output Capacitor

The LDOs on the LM26480 are designed specifically to work with very small ceramic output capacitors. A 1.0  $\mu\text{F}$  ceramic capacitor (temperature types Z5U, Y5V or X7R) with ESR between 5 m $\Omega$  to 500 m $\Omega$ , are suitable in the application circuit. It is also possible to use tantalum or film capacitors at the device output COUT (or VOUT), but these are not as attractive for reasons of size and cost. The output capacitor must meet the requirement for the minimum value of capacitance and also have an ESR value that is within the range 5 m $\Omega$  to 500 m $\Omega$  for stability.

### Capacitor Characteristics

The LDOs are designed to work with ceramic capacitors on the output to take advantage of the benefits they offer. For capacitance values in the range of 0.47  $\mu\text{F}$  to 4.7  $\mu\text{F}$ , ceramic capacitors are the smallest, least expensive and have the lowest ESR values, thus making them best for eliminating high frequency noise. The ESR of a typical 1.0  $\mu\text{F}$  ceramic capacitor is in the range of 20 m $\Omega$  to 40 m $\Omega$ , which easily meets the ESR requirement for stability for the LDOs.

For both input and output capacitors, careful interpretation of the capacitor specification is required to ensure correct device operation. The capacitor value can change greatly, depending on the operating conditions and capacitor type.

In particular, the output capacitor selection should take account of all the capacitor parameters, to ensure that the specification is met within the application. The capacitance can vary with DC bias conditions as well as temperature and frequency of operation. Capacitor values will also show some decrease over time due to aging. The capacitor parameters are also dependent on the particular case size, with smaller sizes giving poorer performance figures in general. As an example, the graph below shows a typical graph comparing different capacitor case sizes in a capacitance vs. DC bias plot.

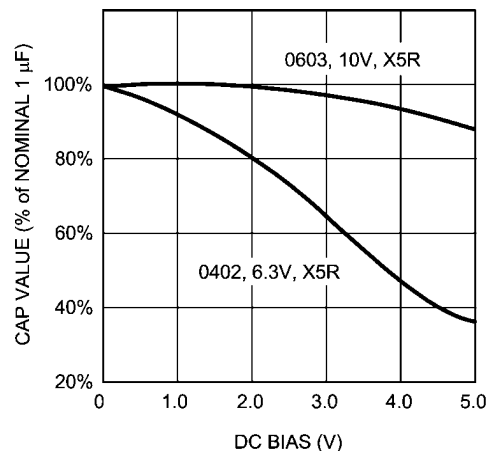

30040416

As shown in the graph, increasing the DC bias condition can result in the capacitance value that falls below the minimum value given in the recommended capacitor specifications table. Note that the graph shows the capacitance out of spec for the 0402 case size capacitor at higher bias voltages. It is therefore recommended that the capacitor manufacturers' specifications for the nominal value capacitor are consulted for all conditions, as some capacitor sizes (e.g. 0402) may not be suitable in the actual application.

The ceramic capacitor's capacitance can vary with temperature. The capacitor type X7R, which operates over a temperature range of  $-55^{\circ}\text{C}$  to  $+125^{\circ}\text{C}$ , will only vary the capacitance to within  $\pm 15\%$ . The capacitor type X5R has a similar tolerance over a reduced temperature range of  $-55^{\circ}\text{C}$  to  $+85^{\circ}\text{C}$ . Many large value ceramic capacitors, larger than 1  $\mu\text{F}$  are manufactured with Z5U or Y5V temperature characteristics. Their capacitance can drop by more than 50% as the temperature varies from  $25^{\circ}\text{C}$  to  $85^{\circ}\text{C}$ . Therefore X7R is recommended over Z5U and Y5V in applications where the ambient temperature will change significantly above or below  $25^{\circ}\text{C}$ .

Tantalum capacitors are less desirable than ceramic for use as output capacitors because they are more expensive when comparing equivalent capacitance and voltage ratings in the 0.47  $\mu\text{F}$  to 4.7  $\mu\text{F}$  range. Another important consideration is that tantalum capacitors have higher ESR values than equivalent size ceramics. This means that while it may be possible to find a tantalum capacitor with an ESR value within the stable range, it would have to be larger in capacitance (which means bigger and more costly) than a ceramic capacitor with the same ESR value. It should also be noted that the ESR of a typical tantalum will increase about 2:1 as the temperature goes from  $25^{\circ}\text{C}$  down to  $-40^{\circ}\text{C}$ , so some guard band must be allowed.

Capacitor	Min Value	Unit	Description	Recommended Type
CLDO1	0.47	μF	LDO1 output capacitor	Ceramic, 6.3V, X5R
CLDO2	0.47	μF	LDO2 output capacitor	Ceramic, 6.3V, X5R
CSW1	10	μF	SW1 output capacitor	Ceramic, 6.3V, X5R
CSW2	10	μF	SW2 output capacitor	Ceramic, 6.3V, X5R

## Analog Power Signal Routing

All power inputs should be tied to the main VDD source (i.e. battery), unless the user wishes to power it from another source. (i.e. powering LDO from Buck output).

The analog VDD inputs power the internal bias and error amplifiers, so they should be tied to the main VDD. The analog VDD inputs must have an input voltage between 2.8 and 5.5 V, as specified in the Electrical Characteristics section of this datasheet.

The other Vins (VINLDO1, VINLDO2, VIN1, VIN2) can actually have inputs lower than 2.8V, as long as it's higher than the programmed output (+0.3V, to be safe). The analog and digital grounds should be tied together outside of the chip to reduce noise coupling.

For more information on board layout techniques, refer to Application Note AN-1187 "Leadless Lead frame Package (LLP)" on <http://www.ti.com> This application note also discusses package handling, solder stencil and the assembly process.

## Board Layout Considerations

PC board layout is an important part of DC-DC converter design. Poor board layout can disrupt the performance of a DC-DC converter and surrounding circuitry by contributing to EMI, ground bounce, and resistive voltage loss in the traces. These can send erroneous signals to the DC-DC converter IC, resulting in poor regulation or instability. Poor layout can also result in re-flow problems leading to poor solder joints, which can result in erratic or degraded performance.

Good layout for the LM26480 bucks can be implemented by following a few simple design rules, as illustrated in [Figure 3](#).

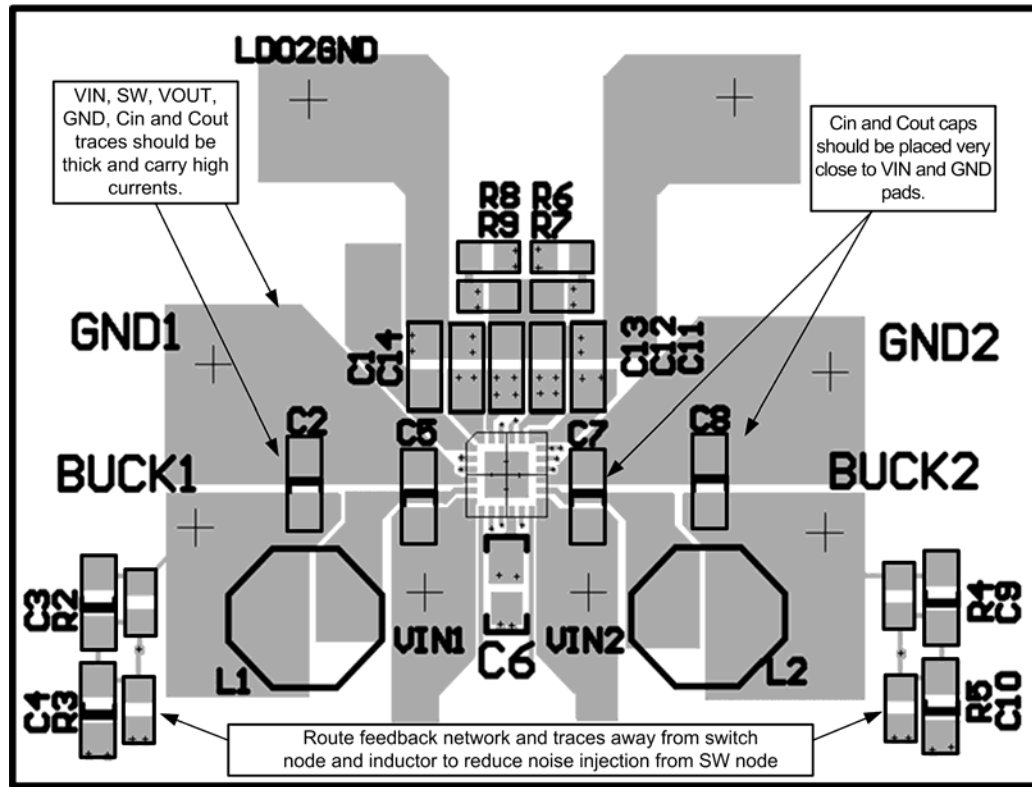

30040468

**FIGURE 3. Board Layout Design Rules for the LM26480**

1. Place the buck inductor and filter capacitors close together and make the trace short. The traces between these components carry relatively high switching currents and act as antennas. Following this rule reduces radiated noise. Place the capacitors and inductor close to the buck.
2. Arrange the components so that the switching current loops curl in the same direction. During the first half of each cycle, current flows from the input filter capacitor, through the buck and inductor to the output filter capacitor and back through ground, forming a current loop. In the second half of each cycle, current is pulled up from ground, through the buck by the inductor, to the output filter capacitor and then back through ground, forming a second current loop. Routing these loops so the current curls in the same direction prevents magnetic field reversal between the two half-cycles and reduces radiated noise.
3. Connect the ground pins of the buck, and filter capacitors together using generous component-side copper fill as a pseudo-ground plane. Then connect this to the ground-plane (if one is used) with several vias. This reduces ground—plane noise by preventing the switching currents from circulating through the ground plane. It also reduces ground bounce at the buck by giving it a low-impedance ground connection.
4. Use wide traces between the power components and for power connections to the DC-DC converter circuit. This reduces voltage errors caused by resistive losses across the traces.
5. Route noise sensitive traces, such as the voltage feedback path, away from noisy traces between the power components. The voltage feedback trace must remain close to the buck circuit and should be routed directly from FB to VOUT at the output capacitor and should be routed opposite to noise components. This reduces EMI radiated onto the DC-DC converter's own voltage feedback trace.

In mobile phones, for example, a common practice is to place the DC-DC converter on one corner of the board, arrange the CMOS digital circuitry around it (since this also generates noise), and then place sensitive preamplifiers and IF stages on the diagonally opposing corner. Often, the sensitive circuitry is shielded with a metal pan and power to it is post-regulated to reduce conducted noise, using low-dropout linear regulators.

## High VIN-High Load Operation

Additional information is provided when the IC is operated at extremes of VIN and regulator loads. These are described in terms of the junction temperature and buck output ripple management.

### Junction Temperature

The maximum junction temperature  $T_{J-MAX-OP}$  of 125°C of the IC package.

The following equations demonstrate junction temperature determination, ambient temperature  $T_{A-MAX}$  and total chip power must be controlled to keep  $T_J$  below this maximum:

$$T_{J-MAX-OP} = T_{A-MAX} + (\theta_{JA}) [^{\circ}\text{C/Watt}] * (P_{D-MAX}) [\text{Watts}]$$

Total IC power dissipation  $P_{D-MAX}$  is the sum of the individual power dissipation of the four regulators plus a minor amount for chip overhead. Chip overhead is bias, TSD and LDO analog.

$$P_{D-MAX} = P_{LDO1} + P_{LDO2} + P_{BUCK1} + P_{BUCK2} + (0.0001\text{A} * V_{IN}) [\text{Watts}].$$

$$\text{Power dissipation of LDO1 (PLDO1)} = (V_{INLDO1} - V_{OUTLDO1}) * I_{OUTLDO1} [V * A]$$

$$\text{Power dissipation of LDO2 (PLDO2)} = (V_{INLDO2} - V_{OUTLDO2}) * I_{OUTLDO2} [V * A]$$

$$\text{Power dissipation of Buck1 (PBuck1)} = P_{OUT} - P_{IN} = V_{OUTBUCK1} - I_{OUTBUCK1} * (1 - \eta_2) / \eta_2 [V * A]$$

$\eta_1$  = efficiency of Buck1

$$\text{Power dissipation of Buck2 (PBuck2)} = P_{OUT} - P_{IN} = V_{OUTBUCK2} - I_{OUTBUCK2} * (1 - \eta_2) / \eta_2 [V * A]$$

$\eta_2$  = efficiency of Buck2

Where  $\eta$  is the efficiency for the specific condition is taken from efficiency graphs.

If VIN and ILOAD increase, the output ripple associated with the Buck Regulators also increases. This mainly occurs with  $V_{IN} > 5.2\text{V}$  and a load current greater than 1.20A. To ensure operation in this area of operation, it is recommended that the system designer circumvents the output ripple issues by installing Schottky diodes on the bucks(s) that are expected to perform under these extreme conditions.

**Physical Dimensions** inches (millimeters) unless otherwise noted

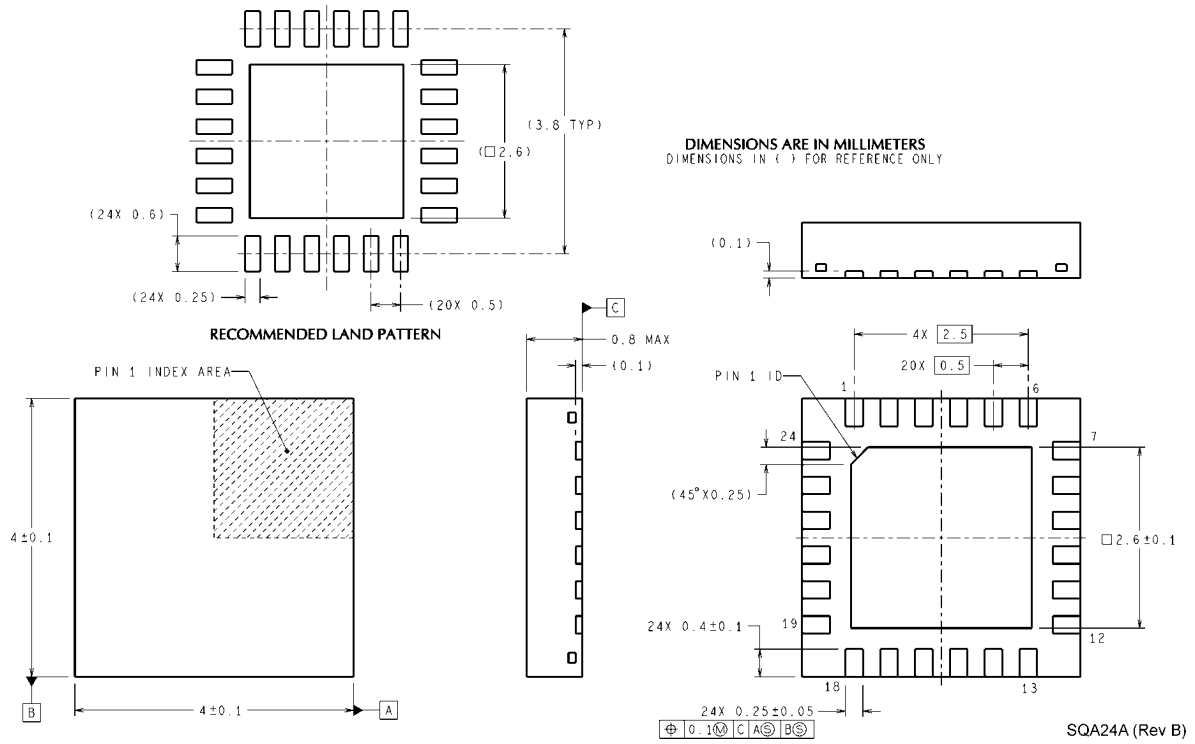

SQA24A (Rev B)

**4 X 4 X 0.8 mm 24-Pin LLP Package**  
**NS Package SQA24A**  
**For ordering, refer to Ordering Information table**

## Notes

# Notes



## IMPORTANT NOTICE

Texas Instruments Incorporated and its subsidiaries (TI) reserve the right to make corrections, enhancements, improvements and other changes to its semiconductor products and services per JESD46, latest issue, and to discontinue any product or service per JESD48, latest issue. Buyers should obtain the latest relevant information before placing orders and should verify that such information is current and complete. All semiconductor products (also referred to herein as "components") are sold subject to TI's terms and conditions of sale supplied at the time of order acknowledgment.

TI warrants performance of its components to the specifications applicable at the time of sale, in accordance with the warranty in TI's terms and conditions of sale of semiconductor products. Testing and other quality control techniques are used to the extent TI deems necessary to support this warranty. Except where mandated by applicable law, testing of all parameters of each component is not necessarily performed.

TI assumes no liability for applications assistance or the design of Buyers' products. Buyers are responsible for their products and applications using TI components. To minimize the risks associated with Buyers' products and applications, Buyers should provide adequate design and operating safeguards.

TI does not warrant or represent that any license, either express or implied, is granted under any patent right, copyright, mask work right, or other intellectual property right relating to any combination, machine, or process in which TI components or services are used. Information published by TI regarding third-party products or services does not constitute a license to use such products or services or a warranty or endorsement thereof. Use of such information may require a license from a third party under the patents or other intellectual property of the third party, or a license from TI under the patents or other intellectual property of TI.

Reproduction of significant portions of TI information in TI data books or data sheets is permissible only if reproduction is without alteration and is accompanied by all associated warranties, conditions, limitations, and notices. TI is not responsible or liable for such altered documentation. Information of third parties may be subject to additional restrictions.

Resale of TI components or services with statements different from or beyond the parameters stated by TI for that component or service voids all express and any implied warranties for the associated TI component or service and is an unfair and deceptive business practice. TI is not responsible or liable for any such statements.

Buyer acknowledges and agrees that it is solely responsible for compliance with all legal, regulatory and safety-related requirements concerning its products, and any use of TI components in its applications, notwithstanding any applications-related information or support that may be provided by TI. Buyer represents and agrees that it has all the necessary expertise to create and implement safeguards which anticipate dangerous consequences of failures, monitor failures and their consequences, lessen the likelihood of failures that might cause harm and take appropriate remedial actions. Buyer will fully indemnify TI and its representatives against any damages arising out of the use of any TI components in safety-critical applications.

In some cases, TI components may be promoted specifically to facilitate safety-related applications. With such components, TI's goal is to help enable customers to design and create their own end-product solutions that meet applicable functional safety standards and requirements. Nonetheless, such components are subject to these terms.

No TI components are authorized for use in FDA Class III (or similar life-critical medical equipment) unless authorized officers of the parties have executed a special agreement specifically governing such use.

Only those TI components which TI has specifically designated as military grade or "enhanced plastic" are designed and intended for use in military/aerospace applications or environments. Buyer acknowledges and agrees that any military or aerospace use of TI components which have **not** been so designated is solely at the Buyer's risk, and that Buyer is solely responsible for compliance with all legal and regulatory requirements in connection with such use.

TI has specifically designated certain components which meet ISO/TS16949 requirements, mainly for automotive use. Components which have not been so designated are neither designed nor intended for automotive use; and TI will not be responsible for any failure of such components to meet such requirements.

### Products

Audio	<a href="http://www.ti.com/audio">www.ti.com/audio</a>
Amplifiers	<a href="http://amplifier.ti.com">amplifier.ti.com</a>
Data Converters	<a href="http://dataconverter.ti.com">dataconverter.ti.com</a>
DLP® Products	<a href="http://www.dlp.com">www.dlp.com</a>
DSP	<a href="http://dsp.ti.com">dsp.ti.com</a>
Clocks and Timers	<a href="http://www.ti.com/clocks">www.ti.com/clocks</a>
Interface	<a href="http://interface.ti.com">interface.ti.com</a>
Logic	<a href="http://logic.ti.com">logic.ti.com</a>
Power Mgmt	<a href="http://power.ti.com">power.ti.com</a>
Microcontrollers	<a href="http://microcontroller.ti.com">microcontroller.ti.com</a>
RFID	<a href="http://www.ti-rfid.com">www.ti-rfid.com</a>
OMAP Applications Processors	<a href="http://www.ti.com/omap">www.ti.com/omap</a>
Wireless Connectivity	<a href="http://www.ti.com/wirelessconnectivity">www.ti.com/wirelessconnectivity</a>

### Applications

Automotive and Transportation	<a href="http://www.ti.com/automotive">www.ti.com/automotive</a>
Communications and Telecom	<a href="http://www.ti.com/communications">www.ti.com/communications</a>
Computers and Peripherals	<a href="http://www.ti.com/computers">www.ti.com/computers</a>
Consumer Electronics	<a href="http://www.ti.com/consumer-apps">www.ti.com/consumer-apps</a>
Energy and Lighting	<a href="http://www.ti.com/energy">www.ti.com/energy</a>
Industrial	<a href="http://www.ti.com/industrial">www.ti.com/industrial</a>
Medical	<a href="http://www.ti.com/medical">www.ti.com/medical</a>
Security	<a href="http://www.ti.com/security">www.ti.com/security</a>
Space, Avionics and Defense	<a href="http://www.ti.com/space-avionics-defense">www.ti.com/space-avionics-defense</a>
Video and Imaging	<a href="http://www.ti.com/video">www.ti.com/video</a>

### TI E2E Community

[e2e.ti.com](http://e2e.ti.com)