

LM2854

4A 500 kHz / 1 MHz PowerWise® Synchronous SIMPLE SWITCHER® Buck Regulator

General Description

The LM2854 PowerWise® SIMPLE SWITCHER® buck regulator is a 500 kHz or 1 MHz step-down switching voltage regulator capable of driving up to a 4A load with exceptional power conversion efficiency, line and load regulation, and output accuracy. The LM2854 can accept an input voltage rail between 2.95V and 5.5V and deliver an adjustable and highly accurate output voltage as low as 0.8V. Externally established soft-start with a small capacitor facilitates controlled start-up, and the LM2854 is capable of starting gracefully into a pre-biased output voltage. Partial internal compensation reduces the number of external passive components and PC board space typically necessary in a voltage mode buck converter application, yet preserving flexibility to deal with ceramic and/or electrolytic based load capacitors. Lossless cycle-by-cycle peak current limit is used to protect the load from an overcurrent or short-circuit fault, and an enable comparator simplifies sequencing applications. The LM2854 is available in an exposed pad TSSOP-16 package that enhances the thermal performance of the regulator.

Features

- Input voltage range of 2.95V to 5.5V
- Maximum load current of 4A
- Wide bandwidth voltage mode control loop, partial internal compensation
- Fixed switching frequency of 500 kHz or 1 MHz
- 35 mΩ integrated MOSFET switches
- Adjustable output voltage down to 0.8V
- Optimized reference voltage initial accuracy and temperature drift
- External soft-start control with tracking capability
- Enable pin with hysteresis
- Low standby current of 230 μA
- Pre-biased load startup capability
- Integrated UVLO, OCP and thermal shutdown
- 100% duty cycle capability
- eTSSOP-16 exposed pad package

Applications

- Low Voltage POL Regulation from 5V or 3.3V Rail
- Local Solution for FPGA/DSP/ASIC/μP Core or I/O Power
- Broadband Networking and Communications Infrastructure
- Portable Computing

Typical Application Circuit

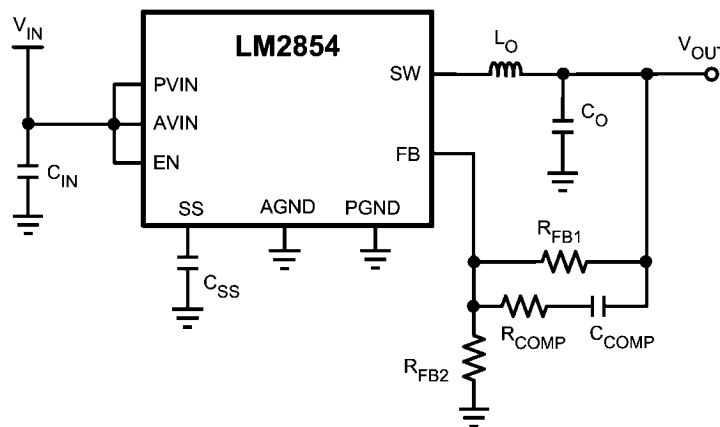

30052801

SIMPLE SWITCHER® is a Registered Trademark of National Semiconductor Corporation.

Connection Diagram

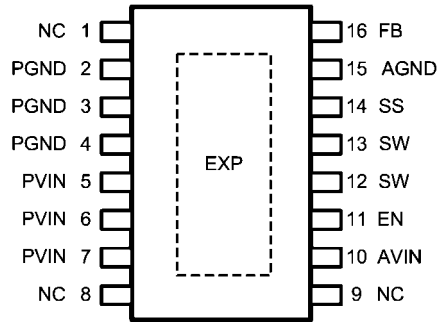

Top View
16-Lead eTSSOP

30052802

Ordering Information

Order Number	Frequency	Package Type	Package Drawing	Supplied As
LM2854MH-500	500 kHz	TSSOP-16 exposed pad	MXA16A	92 Units, Rail
LM2854MHX-500				2500 Units, Tape and Reel
LM2854MH-1000	1 MHz			92 Units, Rail
LM2854MHX-1000				2500 Units, Tape and Reel

Pin Descriptions

Pin Number	Name	Description
1	NC	Reserved for factory use, this pin should be connected to GND to ensure proper operation.
2,3,4	PGND	Power ground pins for the internal power switches. These pins should be connected together locally at the device and tied to the PC board ground plane.
5,6,7	PVIN	Input voltage to the power switches inside the device. These pins should be connected together at the device. A low ESR input capacitance should be located as close as possible to these pins.
8,9	NC	Reserved for factory use, these pins should be connected to GND to ensure proper operation.
10	AVIN	Analog input voltage supply that generates the internal bias. The UVLO circuit derives its input from this pin also. Thus, if the voltage on AVIN falls below the UVLO threshold, both internal FETs are turned off. It is recommended to connect PVIN to AVIN through a low pass RC filter to minimize the influence of input rail ripple and noise on the analog control circuitry. The series resistor should be 1 Ω and the bypass capacitor should be a X7R ceramic type 0.1 μ F to 1.0 μ F.
11	EN	Active high enable input for the device. Typically, turn-on threshold is 1.23V with 0.15V hysteresis. An external resistor divider from PVIN can be used to effectively increase the UVLO turn-on threshold. If not used, the EN pin should be connected to PVIN.
12,13	SW	Switch node pins. This is the PWM output of the internal MOSFET power switches. These pins should be tied together locally and connected to the filter inductor.
14	SS	Soft-start control pin. An internal 2 μ A current source charges an external capacitor connected between this pin and AGND to set the output voltage ramp rate during startup. This pin can also be used to configure the tracking feature.
15	AGND	Quiet analog ground for the internal bias circuitry.
16	FB	Feedback pin is connected to the inverting input of the voltage loop error amplifier. A 0.8V bandgap reference is connected to the non-inverting input of the error amplifier.
EXP	Exposed Pad	Exposed metal pad on the underside of the package with a weak electrical connection to PGND. It is recommended to connect this pad to the PC board ground plane in order to improve thermal dissipation.

Absolute Maximum Ratings (Notes 1, 6)

If Military/Aerospace specified devices are required, please contact the National Semiconductor Sales Office/Distributors for availability and specifications.

PVIN, AVIN, SW, EN, FB, SS to GND	-0.3V to 6.0V
ESD Susceptibility (Note 2)	±2 kV
Power Dissipation	Internally Limited
Junction Temperature	150°C
Storage Temperature Range	-65°C to +150°C

Lead Temperature	
Soldering (10 sec)	260°C
Vapor Phase (60 sec)	215°C
Infrared	220°C

Operating Ratings (Note 6)

PVIN to GND	2.95V to 5.5V
AVIN to GND	2.95V to 5.5V
Junction Temperature	-40°C to +125°C

Electrical Characteristics Specifications with standard typeface are for $T_J = 25^\circ\text{C}$ only; limits in bold face type apply over the Operating Junction Temperature Range T_J range of -40°C to 125°C . Minimum and maximum limits are guaranteed through test, design, or statistical correlation. Typical values represent the most likely parametric norm at $T_J = 25^\circ\text{C}$, and are provided for reference purposes only. AVIN = PVIN = EN = 5.0V, unless otherwise indicated in the Conditions column.

Symbol	Parameter	Conditions	Min (Note 3)	Typ (Note 4)	Max (Note 3)	Units
SYSTEM PARAMETERS						
V_{REF}	Reference Voltage (Note 5)	Measured at the FB pin	0.790	0.8	0.808	V
$\Delta V_{REF}/\Delta V_{AVIN}$	Line Regulation (Note 5)	$\Delta V_{AVIN} = 2.95\text{V to }5.50\text{V}$		0.04	0.6	%
$\Delta V_{REF}/\Delta I_O$	Load Regulation	Normal operation		0.25		mV/A
V_{ON}	UVLO Threshold (AVIN)	Rising		2.6	2.95	V
		Falling hysteresis	25	170	375	mV
$R_{DS(ON)-P}$	PFET On Resistance	$I_{SW} = 4\text{A}$		35	65	m Ω
$R_{DS(ON)-N}$	NFET On Resistance	$I_{SW} = 4\text{A}$		34	65	m Ω
I_{SS}	Soft-Start Current			2		μA
I_{CL}	Peak Current Limit Threshold		4.5	6.0	6.7	A
I_Q	Operating Current	Non-switching		1.7	3	mA
I_{SD}	Shut Down Quiescent Current	EN = 0V		230	500	μA
PWM SECTION						
f_{SW}	Switching Frequency	1 MHz option	800	1050	1160	kHz
		500 kHz option	400	525	580	kHz
D_{range}	PWM Duty Cycle Range		0		100	%
ENABLE CONTROL						
V_{IH}	EN Pin Rising Threshold		0.8	1.23	1.65	V
$V_{EN(HYS)}$	EN Pin Hysteresis			150		mV
THERMAL CONTROL						
T_{SD}	T_J for Thermal Shutdown			165		$^\circ\text{C}$
T_{SD-HYS}	Hysteresis for Thermal Shutdown			10		$^\circ\text{C}$
THERMAL RESISTANCE						
θ_{JA}	Junction to Ambient	MXA16A		35		$^\circ\text{C/W}$

Note 1: Absolute Maximum Ratings are limits beyond which damage to the device may occur. Operating Ratings are conditions under which operation of the device is intended to be functional. For guaranteed specifications and test conditions, see the Electrical Characteristics.

Note 2: The human body model is a 100 pF capacitor discharged through a 1.5 k Ω resistor into each pin. Test method is per JESD22-A114.

Note 3: Min and Max limits are 100% production tested at 25°C. Limits over the operating temperature range are guaranteed through correlation using Statistical Quality Control (SQC) methods. Limits are used to calculate National's Average Outgoing Quality Level (AOQL).

Note 4: Typical numbers are at 25°C and represent the most likely parametric norm.

Note 5: V_{REF} measured in a non-switching, closed-loop configuration.

Note 6: PGND and AGND are electrically connected together on the PC board and the resultant net is termed GND.

Typical Performance Characteristics Unless otherwise specified, the following conditions apply: $V_{IN} = P_{VIN} = A_{VIN} = E_N = 5.0V$, C_{IN} is 47 μF 10V X5R ceramic capacitor, L_O is from TDK SPM6530T family; $T_{AMBIENT} = 25^\circ C$ for efficiency curves, bode plots and waveforms, and $T_J = 25^\circ C$ for all others.

Feedback Voltage vs. Temperature

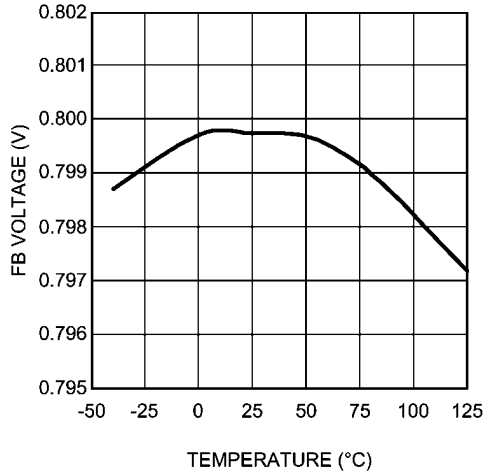

30052803

UVLO Threshold vs. Temperature

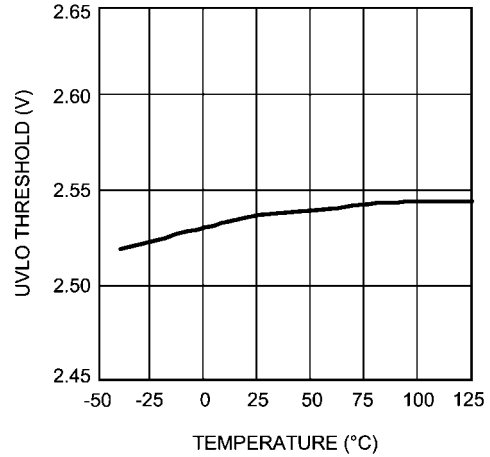

30052804

Soft Start Current vs. Temperature

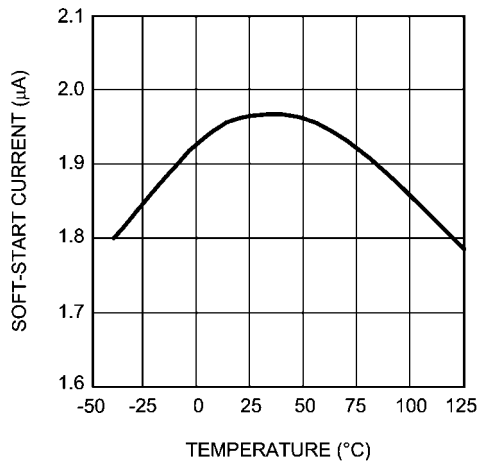

30052805

Enable Threshold vs. Temperature

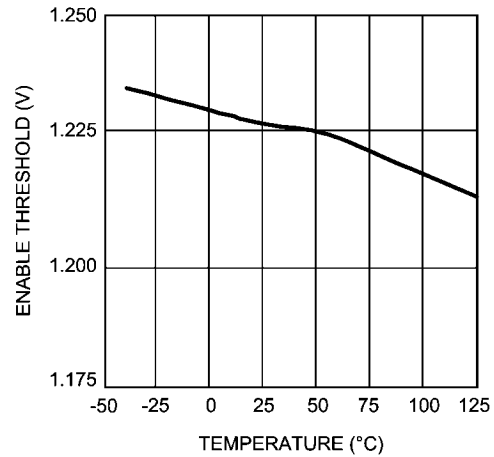

30052806

Switching Frequency vs. Temperature

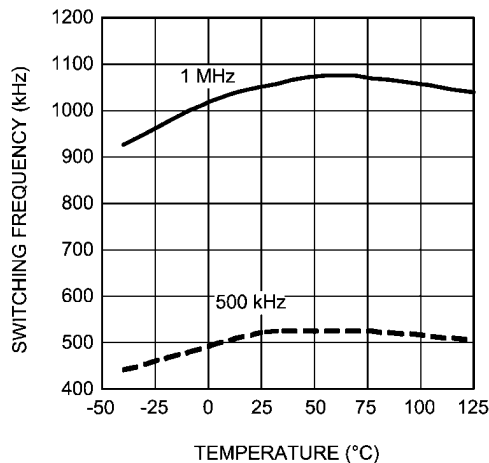

30052807

PMOS $R_{DS(ON)}$ vs. Temperature

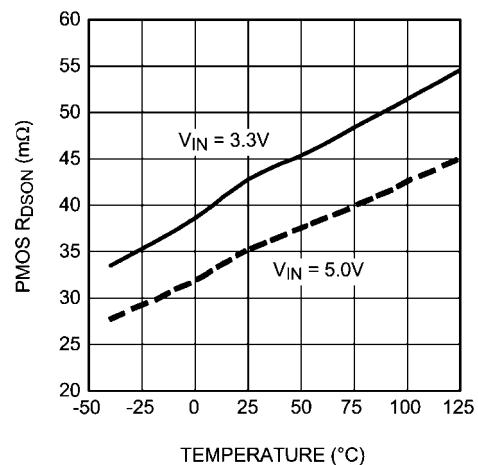

30052808

NMOS $R_{DS(ON)}$ vs. Temperature

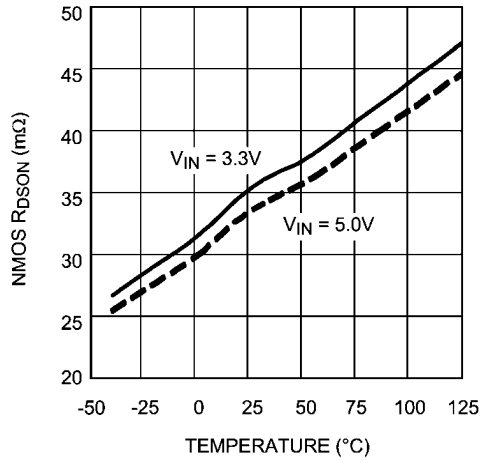

30052809

I_Q (operating) vs. V_{IN} and Temperature

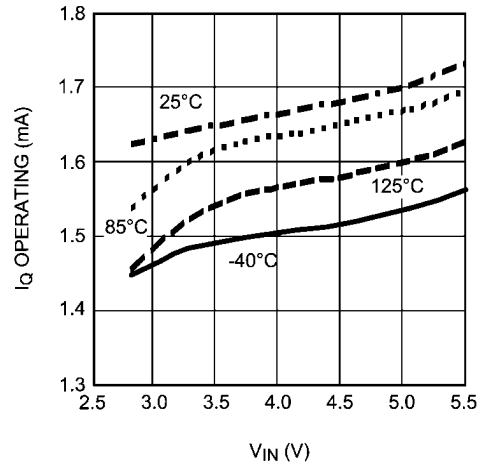

30052810

Peak Current Limit vs. Temperature

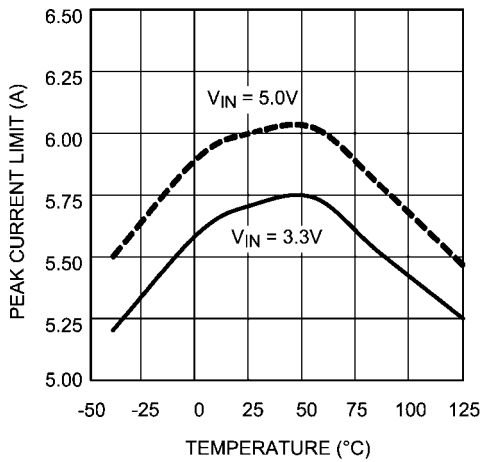

30052811

Feedback Voltage vs. V_{IN}

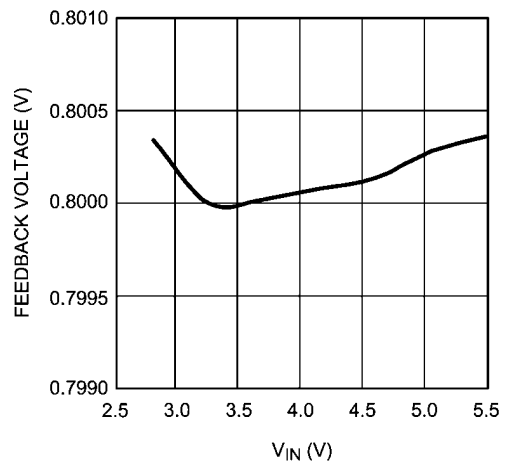

30052812

I_Q (disabled) vs. V_{IN} and Temperature, EN = 0V

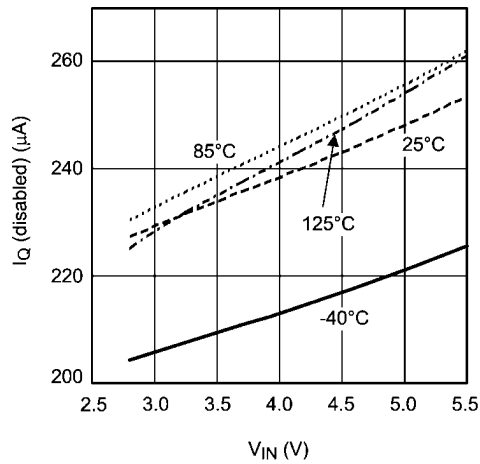

30052813

Switching Frequency vs. V_{IN}

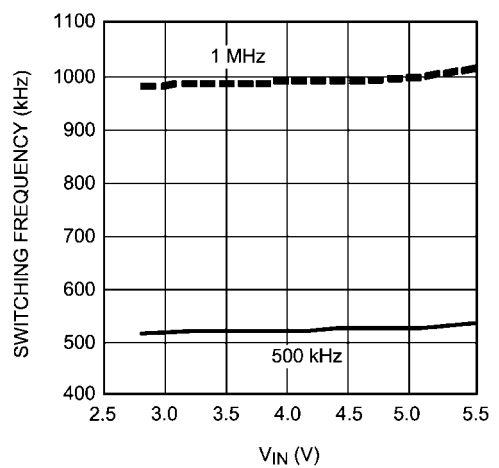

30052814

LM2854 1 MHz Efficiency vs. I_{OUT}
 $V_{OUT} = 0.8V, L_O = 0.47 \mu H, 3.3 m\Omega DCR$

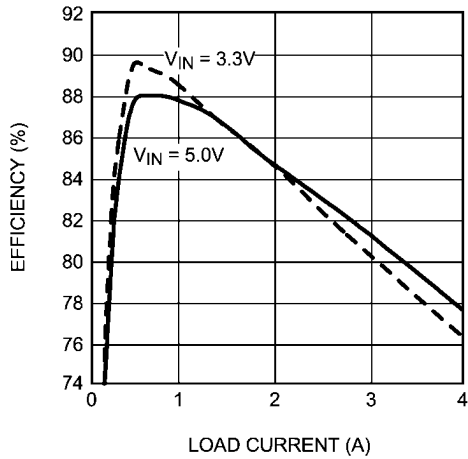

30052815

LM2854 1 MHz Efficiency vs. I_{OUT}
 $V_{OUT} = 2.5V, L_O = 1.0 \mu H, 7.1 m\Omega DCR$

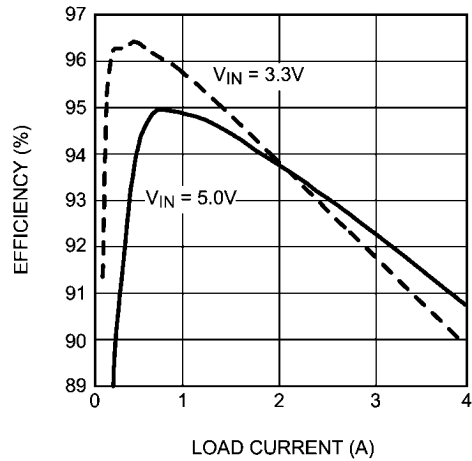

30052816

LM2854 1 MHz Efficiency vs. I_{OUT}
 $V_{OUT} = 1.2V, L_O = 0.68 \mu H, 4.9 m\Omega DCR$

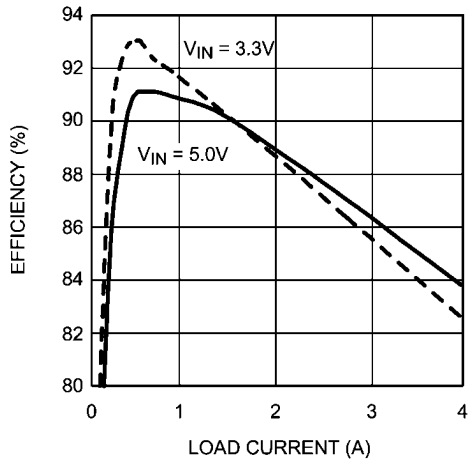

30052817

LM2854 1 MHz Efficiency vs. I_{OUT}
 $V_{OUT} = 3.3V, L_O = 1.0 \mu H, 7.1 m\Omega DCR$

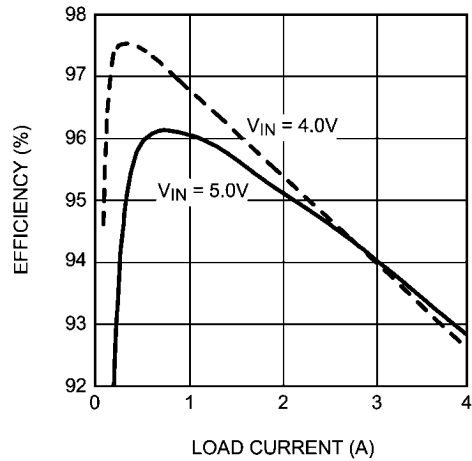

30052818

LM2854 1 MHz Efficiency vs. I_{OUT}
 $V_{OUT} = 1.8V, L_O = 1.0 \mu H, 7.1 m\Omega DCR$

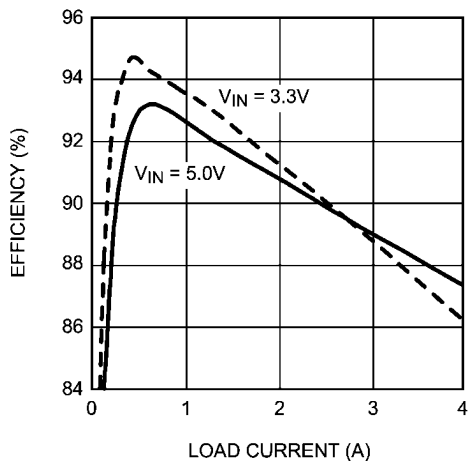

30052819

LM2854 500 kHz Efficiency vs. I_{OUT}
 $V_{OUT} = 0.8V, L_O = 1.0 \mu H, 7.1 m\Omega DCR$

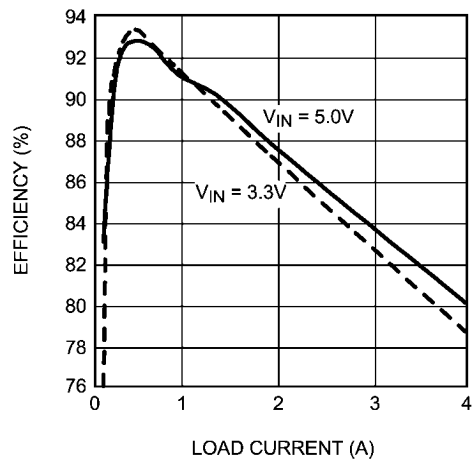

30052820

LM2854 500 kHz Efficiency vs. I_{OUT}
 $V_{OUT} = 2.5V, L_O = 2.2 \mu H, 16 m\Omega DCR$

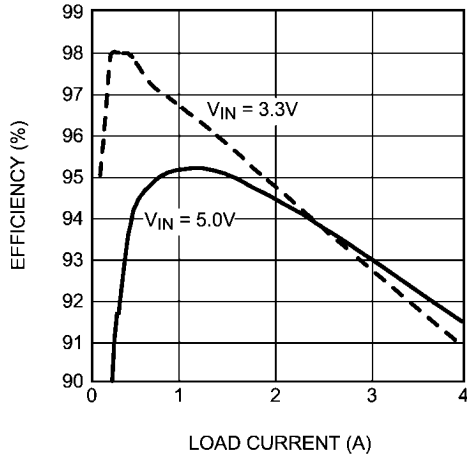

30052821

LM2854 500 kHz Efficiency vs. I_{OUT}
 $V_{OUT} = 1.2V, L_O = 1.5 \mu H, 9.7 m\Omega DCR$

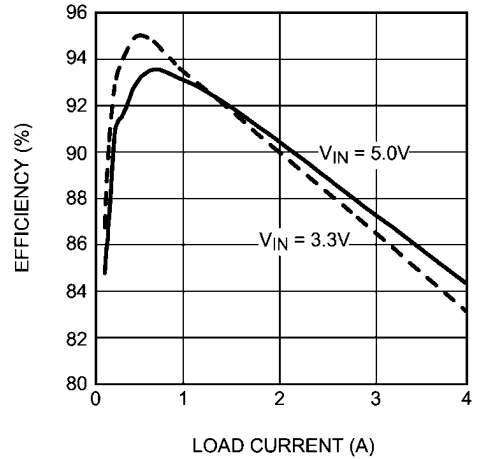

30052822

LM2854 500 kHz Efficiency vs. I_{OUT}
 $V_{OUT} = 3.3V, L_O = 1.5 \mu H, 9.7 m\Omega DCR$

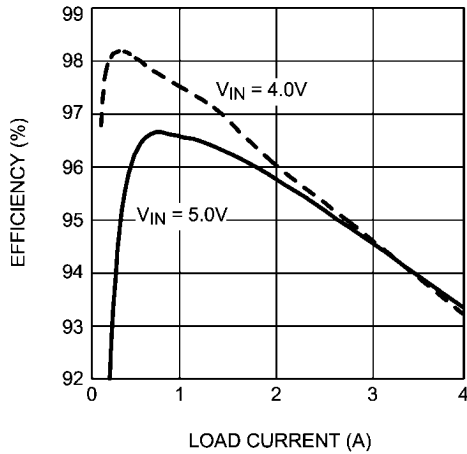

30052823

LM2854 500 kHz Efficiency vs. I_{OUT}
 $V_{OUT} = 1.8V, L_O = 1.5 \mu H, 9.7 m\Omega DCR$

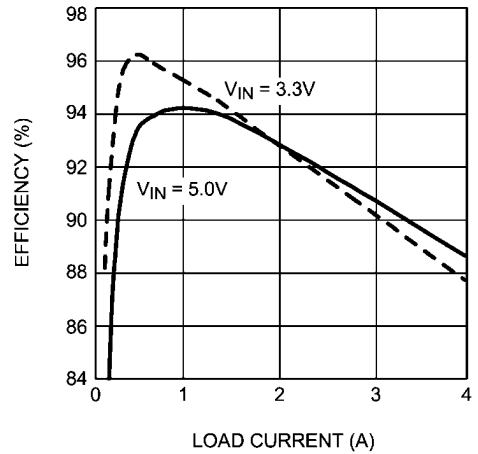

30052824

LM2854 1 MHz Bode Plot
 $V_{IN} = 3.3V, V_{OUT} = 1.8V, I_{OUT} = 4A$
 $R_{FB1} = 150 k\Omega, R_{COMP} = 1 k\Omega, C_{COMP} = 100 pF,$
 $L_{OUT} = 0.82 \mu H, C_{OUT} = 100 \mu F$ ceramic

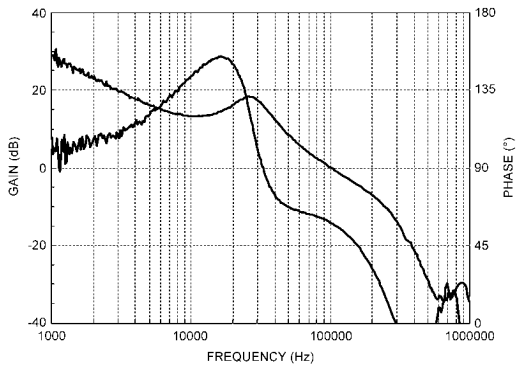

30052825

LM2854 500 kHz Bode Plot
 $V_{IN} = 3.3V, V_{OUT} = 1.8V, I_{OUT} = 4A$
 $R_{FB1} = 250 k\Omega, R_{COMP} = 1 k\Omega, C_{COMP} = 47 pF,$
 $L_{OUT} = 1.5 \mu H, C_{OUT} = 100 \mu F$ ceramic

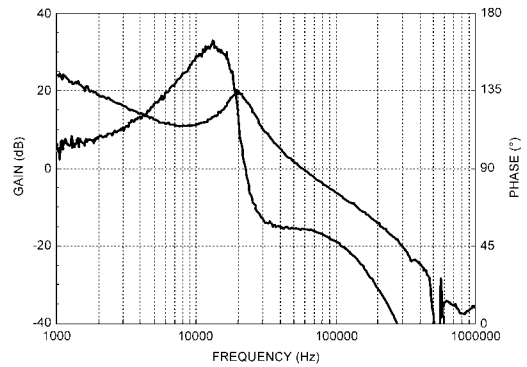

30052826

LM2854 1 MHz Bode Plot
 $V_{IN} = 5.0V, V_{OUT} = 1.8V, I_{OUT} = 4A$
 $R_{FB1} = 150\text{ k}\Omega, R_{COMP} = 1\text{ k}\Omega, C_{COMP} = 100\text{ pF}$
 $L_{OUT} = 0.82\text{ }\mu\text{H}, C_{OUT} = 100\text{ }\mu\text{F}$

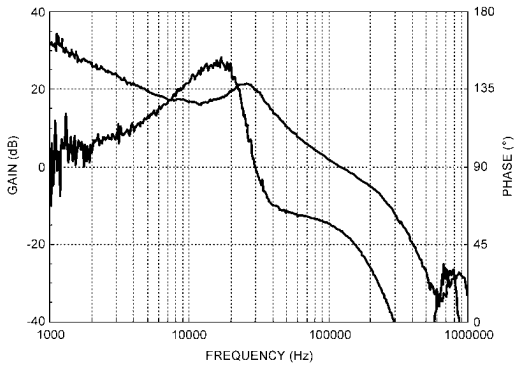

30052827

LM2854 500 kHz Bode Plot
 $V_{IN} = 5.0V, V_{OUT} = 1.8V, I_{OUT} = 4A$
 $R_{FB1} = 250\text{ k}\Omega, R_{COMP} = 1\text{ k}\Omega, C_{COMP} = 47\text{ pF}$
 $L_{OUT} = 1.5\text{ }\mu\text{H}, C_{OUT} = 100\text{ }\mu\text{F ceramic}$

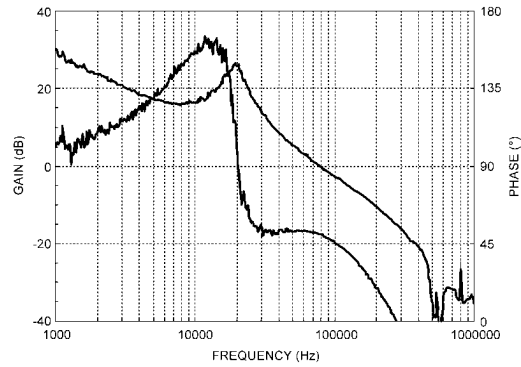

30052828

LM2854 1 MHz Bode Plot
 $V_{IN} = 5.0V, V_{OUT} = 3.3V, I_{OUT} = 4A$
 $R_{FB1} = 150\text{ k}\Omega, R_{COMP} = 1\text{ k}\Omega, C_{COMP} = 68\text{ pF}$
 $L_{OUT} = 0.82\text{ }\mu\text{H}, C_{OUT} = 100\text{ }\mu\text{F ceramic}$

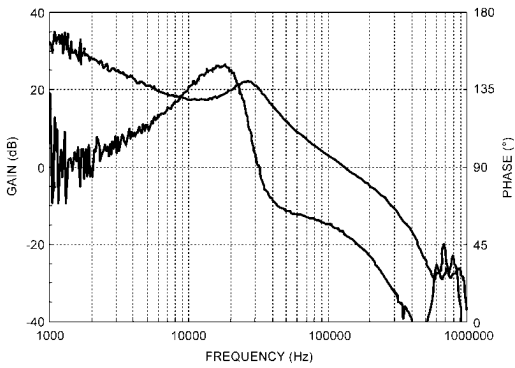

30052829

LM2854 500 kHz Bode Plot
 $V_{IN} = 5.0V, V_{OUT} = 3.3V, I_{OUT} = 4A$
 $R_{FB1} = 250\text{ k}\Omega, R_{COMP} = 1\text{ k}\Omega, C_{COMP} = 33\text{ pF}$
 $L_{OUT} = 1.5\text{ }\mu\text{H}, C_{OUT} = 100\text{ }\mu\text{F ceramic}$

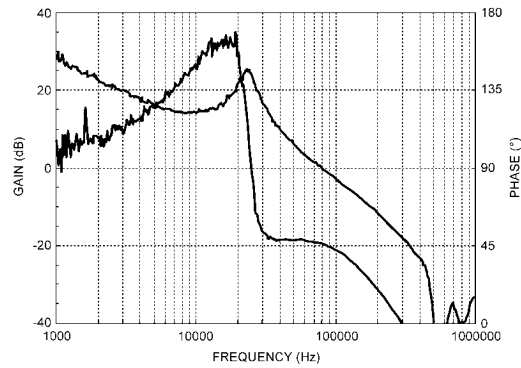

30052830

LM2854 500 kHz Power On Characteristic
 $V_{IN} = 5.0V, V_{OUT} = 1.8V, I_{OUT} = 4A, C_{SS} = 220\text{ pF}$

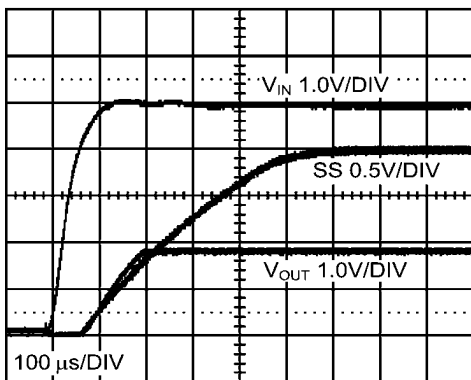

30052831

LM2854 500 kHz Power On via Enable
 $V_{IN} = 5.0V, V_{OUT} = 1.8V, I_{OUT} = 4A, C_{SS} = 220\text{ pF}$

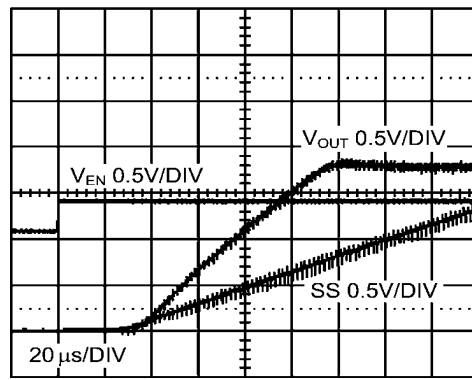

30052832

LM2854 500 kHz Power Off Characteristic
 $V_{IN} = 5.0V$, $V_{OUT} = 1.8V$, $I_{OUT} = 4A$, $C_{SS} = 220\text{ pF}$

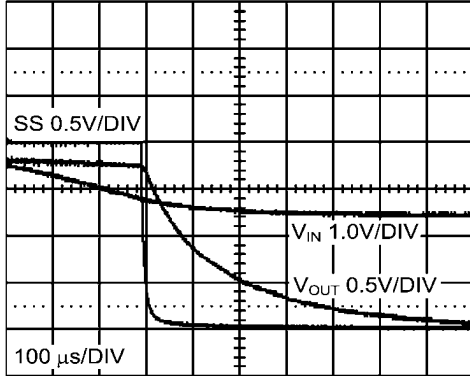

30052833

LM2854 1 MHz Load Transient Response
 $V_{IN} = 5.0V$, $V_{OUT} = 3.3V$, $I_{OUT} = 0.5A$ to $4A$ to $0.5A$ step
 $di/dt \approx 4A/\mu s$, $C_O = 100\text{ }\mu F$ ceramic

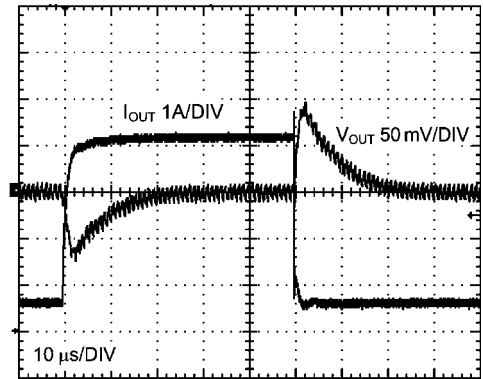

30052834

LM2854 500 kHz Switch Node Voltage
 (oscilloscope set at infinite persistence)
 $V_{IN} = 5.0V$, $V_{OUT} = 2.5V$, $I_{OUT} = 4A$

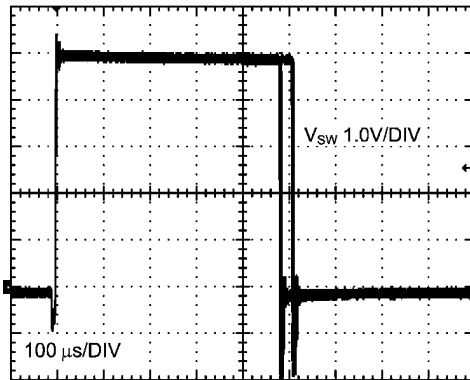

30052835

LM2854 500 kHz Startup Waveform
 $V_{OUT} = 2.5V$, $I_{OUT} = 0A$

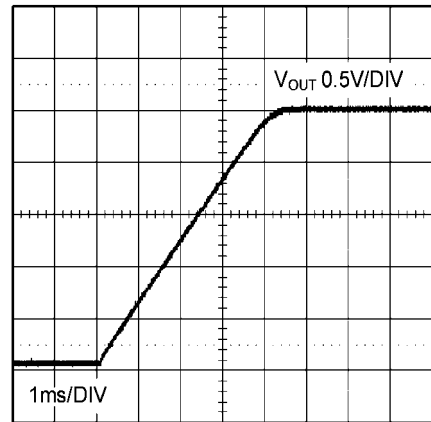

30052856

LM2854 500 kHz Pre-Biased Startup Waveform
 (oscilloscope set at infinite persistence)
 $V_{OUT} = 2.5V$, $I_{OUT} = 0A$, $V_{PRE-BIAS} = 1.25V$

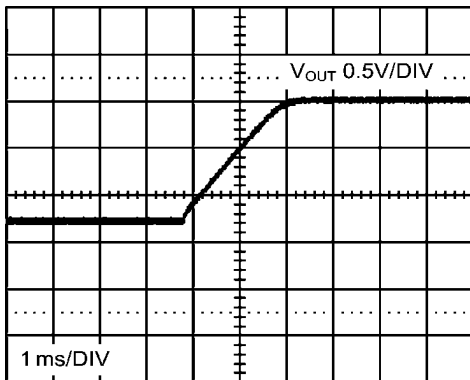

30052855

Block Diagram

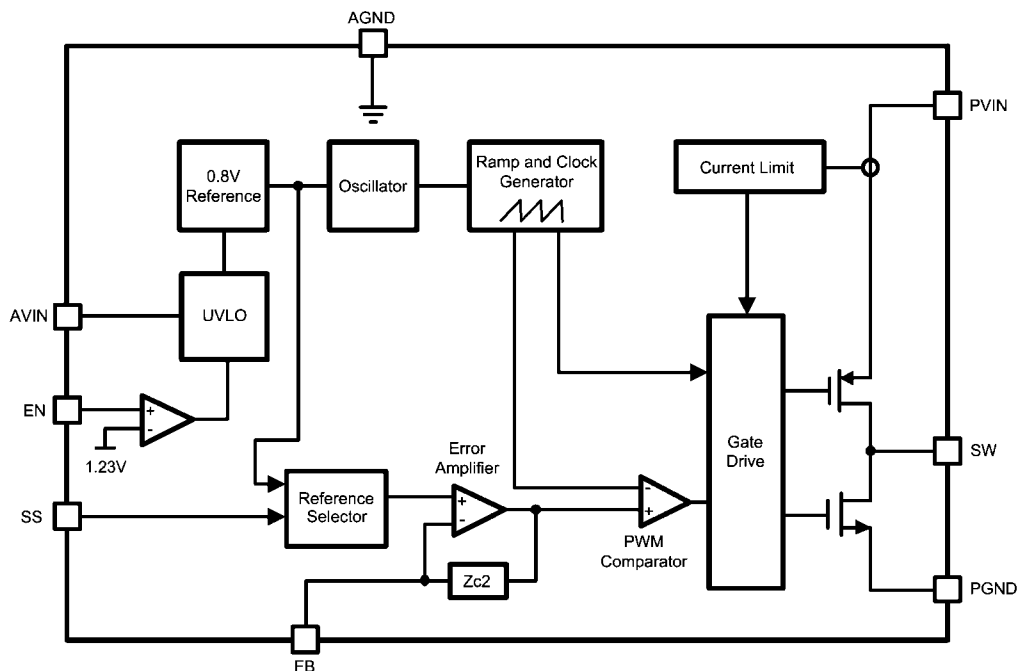

30052836

Applications Information

GENERAL

The LM2854 PowerWise® synchronous DC-DC buck regulator belongs to the National Semiconductor SIMPLE SWITCHER® family of switching regulators. Integration of the power MOSFETs and associated drivers, compensation component network and the PWM controller reduces the number of external components necessary for a complete power supply design, without sacrificing performance.

Operation Description

SWITCHING FREQUENCY

The LM2854 is available in two switching frequency options, 500 kHz and 1 MHz. Generally, a higher switching frequency allows for faster transient response and a reduction in the footprint area and volume of the external power stage components, while a lower switching frequency affords better efficiency. These factors should be considered when selecting the appropriate switching frequency for a given application.

ENABLE

The LM2854 features an enable (EN) pin and associated comparator to allow the user to easily sequence the LM2854 from an external voltage rail, or to manually set the input UVLO threshold. The turn-on or rising threshold and hysteresis for this comparator are typically 1.23V and 0.15V respectively. The precise reference for the enable comparator allows the user to guarantee that the LM2854 will be disabled when the system demands it to be.

SOFT-START

The LM2854 begins to operate when both the AVIN and EN voltages exceed the rising UVLO and enable thresholds, re-

spectively. A controlled soft-start eliminates inrush currents during start-up and allows the user more control and flexibility when sequencing the LM2854 with other power supplies. An external soft-start capacitor is used to control the LM2854 start-up time. During soft-start, the voltage on the feedback pin is connected internally to the non-inverting input of the error amplifier. The soft-start period lasts until the voltage on the soft-start pin exceeds the LM2854 reference voltage of 0.8V. At this point, the reference voltage takes over at the non-inverting amplifier input.

In the event of either AVIN or EN decreasing below the falling UVLO or enable threshold respectively, the voltage on the soft-start pin is collapsed by discharging the soft-start capacitor through a 5 kΩ transistor to ground.

TRACKING

The LM2854 can track the output of a master power supply during soft-start by connecting a resistor divider to the SS pin. In this way, the output voltage slew rate of the LM2854 will be controlled by a master supply for loads that require precise sequencing. When the tracking function is used, a small value soft-start capacitor can be connected to the SS pin to alleviate output voltage overshoot when recovering from a current limit fault.

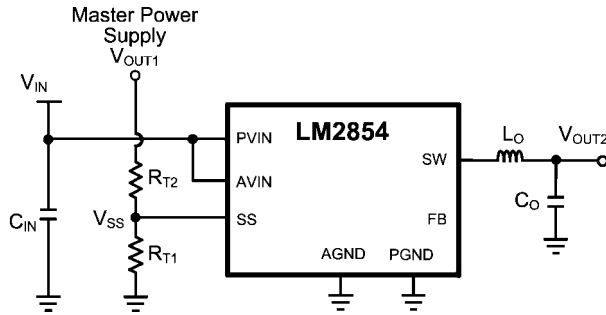

30052857

PRE-BIASED STARTUP CAPABILITY

The LM2854 is in a pre-biased state when the device starts up with an output voltage greater than zero. This often occurs in many multi-rail applications such as when powering an FPGA, ASIC, or DSP. The output can be pre-biased in these applications through parasitic conduction paths from one supply rail to another. Even though the LM2854 is a synchronous converter, it will not pull the output low when a pre-bias condition exists. The LM2854 will not sink current during start up until the soft-start voltage exceeds the voltage on the FB pin. Since the device can not sink current it protects the load from damage that might otherwise occur if current is conducted through the parasitic paths of the load.

FEEDBACK VOLTAGE ACCURACY

The FB pin is connected to the inverting input of the voltage loop error amplifier and during closed loop operation its reference voltage is 0.8V. The FB voltage is accurate to within $-1.25\% / +1.0\%$ over temperature. Additionally, the LM2854 contains error nulling circuitry to substantially eliminate the feedback voltage over temperature drift as well as the long term aging effects of the internal amplifiers. In addition, the 1/f noise of the bandgap amplifier and reference are dramatically reduced. The manifestation of this circuit action is that the duty cycle will have two slightly different but distinct operating points, each evident every other switching cycle. The oscilloscope plot shown previously of the SW pin with infinite persistence set shows this behavior. No discernible effect is evident on the output due to LC filter attenuation. For further information, a National Semiconductor white paper is available on this topic.

POSITIVE CURRENT LIMIT

The LM2854 employs lossless cycle-by-cycle high-side current limit circuitry to limit the peak current through the high-side FET. The peak current limit threshold, denoted I_{CL} , is nominally set at 6A internally. When a current greater than I_{CL} is sensed through the PFET, its on-time is immediately terminated and the NFET is activated. The NFET stays on for the entire next four switching cycles (effectively four PFET pulses are skipped). During these skipped pulses, the voltage on the soft-start pin is reduced by discharging the soft-start capacitor by a current sink on the soft-start pin of nominally 6 μ A or 14 μ A for the 500 kHz or 1 MHz options, respectively. Subsequent over-current events will drain more and more charge from the soft-start capacitor, effectively decreasing the reference voltage as the output droops due to the pulse skipping. Reactivation of the soft-start circuitry ensures that when the over-current situation is removed, the part will resume normal operation smoothly.

NEGATIVE CURRENT LIMIT

The LM2854 implements negative current limit detection circuitry to prevent large negative current in the inductor. When

the negative current sensed in the low-side NFET is below approximately $-0.4A$, the present switching cycle is immediately terminated and both FETs are turned off. When both FETs are off, the negative inductor current originally flowing in the low-side NFET and into the SW pin commutates to the high-side PFET's body diode and ramps back to zero. At this point, the SW pin becomes a high impedance node and ringing can be observed on the SW node as the stored energy in the inductor is dissipated while resonating with the parasitic nodal capacitance.

OVER-TEMPERATURE PROTECTION

When the LM2854 senses a junction temperature greater than $165^{\circ}C$, both switching FETs are turned off and the part enters a sleep state. Upon sensing a junction temperature below $155^{\circ}C$, the part will re-initiate the soft-start sequence and begin switching once again. This feature is provided to prevent catastrophic failure due to excessive thermal dissipation.

LOOP COMPENSATION

The LM2854 preserves flexibility by integrating the control components around the error amplifier while utilizing three small external compensation components from V_{OUT} to FB. An integrated type II (two pole, one zero) voltage-mode compensation network is featured. To ensure stability, an external resistor and small value capacitor can be added across the upper feedback resistor as a pole-zero pair to complete a type III (three pole, two zero) compensation network. For correct selection of these components, see the design section of this datasheet.

Design Guidelines

INPUT FILTER CAPACITOR

Fast switching currents place a large strain on the input supply to a buck regulator. A capacitor placed close to the PVIN and PGND pins of the LM2854 helps to supply the instantaneous charge required when the regulator demands a pulse of current every switching cycle. In fact, the input capacitor conducts a square-wave current of peak-to-peak amplitude equal to I_{OUT} . With this high AC current present in the input capacitor, the RMS current rating becomes an important parameter. The necessary RMS current rating of the input capacitor to a buck regulator can be estimated by

$$I_{Cin(RMS)} = I_{OUT} \sqrt{D(1-D)}$$

where the PWM duty cycle, D, is given by

$$D = \frac{V_{OUT}}{V_{IN}}$$

Neglecting capacitor ESR, the resultant input capacitor AC ripple voltage is a triangular waveform with peak-to-peak amplitude specified as follows

$$\Delta V_{in} = \frac{V_{OUT} D(1-D)}{f_{SW} C_{IN}}$$

The maximum input capacitor ripple voltage and RMS current occur at 50% duty cycle. A 22 μ F or 47 μ F high quality dielectric (X5R, X7R) ceramic capacitor with adequate voltage rating is typically sufficient as an input capacitor to the

LM2854. The input capacitor should be placed as close as possible to the PVIN and PGND pins to substantially eliminate the parasitic effects of any stray inductance or resistance on the PC board and supply lines. Additional bulk capacitance with higher ESR may be required to damp any resonance effects of the input capacitance and parasitic inductance.

AVIN FILTERING COMPONENTS

In addition to the large input filter capacitor, a smaller ceramic capacitor such as a 0.1 μF or 1.0 μF is recommended between AVIN and AGND to filter high frequency noise present on the PVIN rail from the quiet AVIN supply. For additional filtering in noisy environments, a small RC filter can be used on the AVIN pin as shown below.

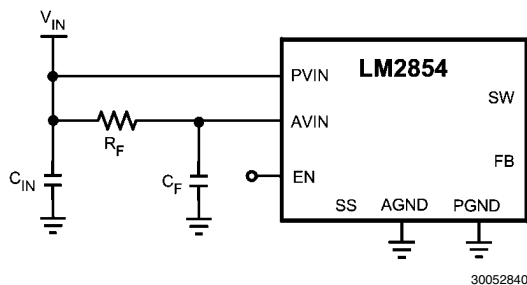

In general, R_F is typically selected between 1Ω and 10Ω so that the steady state voltage drop across the resistor due to the AVIN bias current does not affect the UVLO level. Recommended filter capacitor, C_F , is 1.0 μF in X5R or X7R dielectric.

SOFT-START CAPACITOR

When the LM2854 is enabled, the output voltage will ramp up linearly in the time dictated by the following relationship

$$t_{SS} = \frac{C_{SS} \times V_{REF}}{I_{SS}}$$

where V_{REF} is the internal reference voltage (nominally 0.8V), I_{SS} is the soft-start charging current (nominally 2 μA) and C_{SS} is the external soft-start capacitance. Rearranging this equation allows for the necessary soft-start capacitor for a given startup time to be calculated as follows

$$C_{SS} = \frac{t_{SS} \times 2 \mu\text{A}}{0.8\text{V}}$$

Thus, the required soft start capacitor per unit output voltage startup time is given by

$$C_{SS} = 2.5 \text{ nF} / \text{ms}$$

For example, a 10 nF soft-start capacitor will yield a 4 ms soft-start time.

TRACKING - EQUAL SOFT-START TIME

One way to use the tracking feature is to design the tracking resistor divider so that the master supply output voltage, V_{OUT1} , and the LM2854 output voltage, V_{OUT2} , both rise together and reach their target values at the same time. This is termed ratiometric startup. For this case, the equation governing the values of tracking divider resistors R_{T1} and R_{T2} is given by

$$R_{T1} = \frac{R_{T2}}{V_{OUT1} - 1.0\text{V}}$$

The above equation includes an offset voltage to ensure that the final value of the SS pin voltage exceeds the reference voltage of the LM2854. This offset will cause the LM2854 output voltage to reach regulation slightly before the master supply. A value of 33 k Ω 1% is recommended for R_{T2} as a compromise between high precision and low quiescent current through the divider while minimizing the effect of the 2 μA soft-start current source.

For example, If the master supply voltage V_{OUT1} is 3.3V and the LM2854 output voltage was 1.8V, then the value of R_{T1} needed to give the two supplies identical soft-start times would be 14.3 k Ω . A timing diagram for this example, the equal soft-start time case, is shown below.

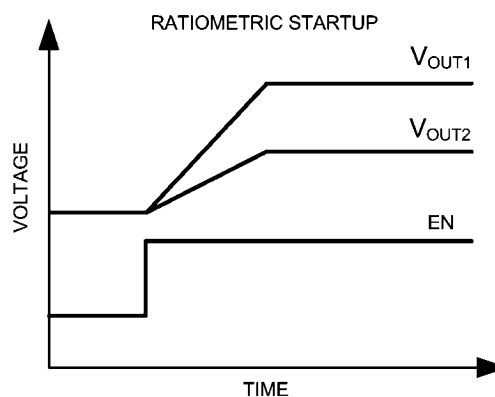

TRACKING - EQUAL SLEW RATES

Alternatively, the tracking feature can be used to have similar output voltage ramp rates. This is referred to as simultaneous startup. In this case, the tracking resistors can be determined based on the following equation

$$R_{T1} = \frac{0.8\text{V}}{V_{OUT2} - 0.8\text{V}} R_{T2}$$

and to ensure proper overdrive of the SS pin

$$V_{OUT2} < 0.8 V_{OUT1}$$

For the example case of $V_{OUT1} = 5\text{V}$ and $V_{OUT2} = 2.5\text{V}$, with R_{T2} set to 33 k Ω as before, R_{T1} is calculated from the above equation to be 15.5 k Ω . A timing diagram for the case of equal slew rates is shown below.

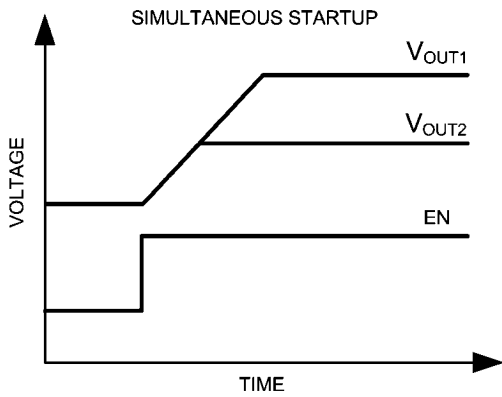

30052861

ENABLE AND UVLO

Using a resistor divider from V_{IN} to EN as shown in the schematic diagram below, the input voltage at which the part begins switching can be increased above the normal input UVLO level according to

$$V_{IN(UVLO)} = 1.23V \frac{R_{EN1} + R_{EN2}}{R_{EN2}}$$

For example, suppose that the required input UVLO level is 3.69V. Choosing R_{EN2} = 10 kΩ, then we calculate R_{EN1} = 20 kΩ.

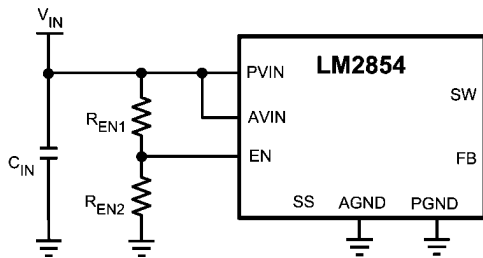

30052844

Alternatively, the EN pin can be driven from another voltage source to cater for system sequencing requirements commonly found in FPGA and other multi-rail applications. The following schematic shows an LM2854 that is sequenced to start based on the voltage level of a master system rail.

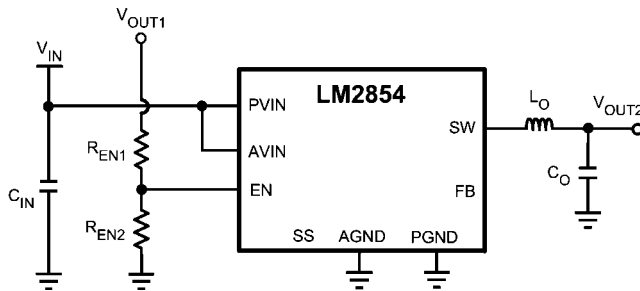

30052845

OUTPUT VOLTAGE SETTING

A divider resistor network from V_{OUT} to the FB pin determines the desired output voltage as follows

$$V_{OUT} = 0.8V \frac{R_{FB1} + R_{FB2}}{R_{FB2}}$$

R_{FB1} is defined based on the voltage loop requirements and R_{FB2} is then selected for the desired output voltage. These resistors are normally selected as 0.5% or 1% tolerance.

COMPENSATION COMPONENT SELECTION

The power stage transfer function of a voltage mode buck converter has a complex double pole related to the LC output filter and a left half plane zero due to the output capacitor ESR, denoted R_{ESR}. The locations of these singularities are given respectively by

$$f_{LC} = \frac{1}{2\pi \sqrt{L_O C_O \left(\frac{R_{ESR} + R_L}{R_{DCR} + R_L} \right)}} \cong \frac{1}{2\pi \sqrt{L_O C_O}}$$

$$f_{ESR} = \frac{1}{2\pi R_{ESR} C_O}$$

where C_O is the output capacitance value appropriately derated for applied voltage and operating temperature, R_L is the effective load resistance and R_{DCR} is the series damping resistance associated with the inductor and power switches.

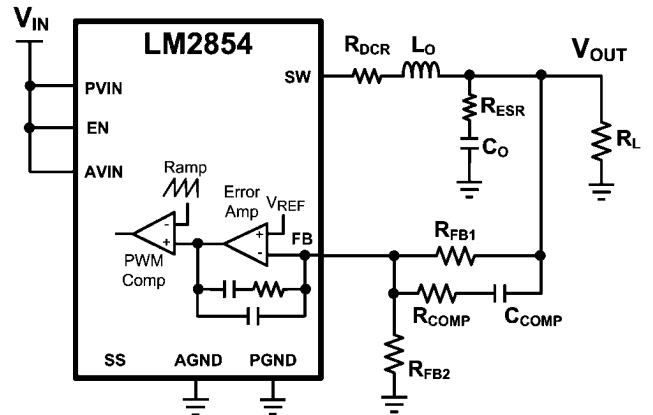

30052848

The conventional compensation strategy employed with voltage mode control is to use two compensator zeros to offset the LC double pole, one compensator pole located to cancel the output capacitor ESR zero and one compensator pole located between one third and one half switching frequency for high frequency noise attenuation.

The LM2854 internal compensation components are designed to locate a pole at the origin and a pole at high frequency as mentioned above. Furthermore, a zero is located at 8.8 kHz or 17.6 kHz for the 500 kHz or 1 MHz options, respectively, to approximately cancel the likely location of one LC filter pole.

The three external compensation components, R_{FB1}, R_{COMP} and C_{COMP}, are selected to position a zero at or below the LC pole location and a pole to cancel the ESR zero. The voltage loop crossover frequency, f_{loop}, is usually selected between one tenth to one fifth of the switching frequency

$$0.1f_{SW} \leq f_{loop} \leq 0.2f_{SW}$$

A simple solution for the required external compensation capacitor, C_{COMP}, with type III voltage mode control can be expressed as

$$C_{COMP}(pF) = \alpha \frac{L_o(\mu H)C_o(\mu F)}{V_{IN}(V)} f_{loop}(kHz)$$

where the constant α is nominally 0.038 or 0.075 for the 500 kHz or 1 MHz options, respectively. This assumes a compensator pole cancels the output capacitor ESR zero. Furthermore, since the modulator gain is proportional to V_{IN} , the loop crossover frequency increases with V_{IN} . Thus, it is recommended to design the loop at maximum expected V_{IN} .

The upper feedback resistor, R_{FB1} , is selected to provide adequate mid-band gain and to locate a zero at or below the LC pole frequency. The series resistor, R_{COMP} , is selected to locate a pole at the ESR zero frequency. Thus

$$R_{FB1} = \frac{1}{2\pi C_{COMP} f_{LC}}$$

$$R_{COMP} = \frac{1}{2\pi C_{COMP} f_{ESR}}$$

Note that the lower feedback resistor, R_{FB2} , has no impact on the control loop from an AC standpoint since the FB pin is the input to an error amplifier and effectively at AC ground. Hence, the control loop can be designed irrespective of output voltage level. The only caveat here is the necessary derating of the output capacitance with applied voltage. Having chosen R_{FB1} as above, R_{FB2} is then selected for the desired output voltage.

Table 1 and Table 2 list inductor and ranges of capacitor values that work well with the LM2854, along with the associated compensation components to ensure stable operation. Values different than those listed may be used, but the compensation components may need to be recalculated to avoid degradation in phase margin. Note that the capacitance ranges specified refer to in-circuit values where the nominal capacitance value is adequately derated for applied voltage.

FILTER INDUCTOR AND OUTPUT CAPACITOR SELECTION

In a buck regulator, selection of the filter inductor and capacitor will affect many key system parameters, including stability, transient response and efficiency. The LM2854 can accommodate relatively wide ranges of output capacitor and filter inductor values in a typical application and still achieve

excellent load current transient performance and low output voltage ripple.

The inductance is chosen such that the peak-to-peak inductor current ripple, Δi_L , is approximately 25 to 40% of I_{OUT} as follows

$$L_o = \frac{V_{OUT}(1-D)}{\Delta i_L f_{sw}} \cong \frac{V_{OUT}(1-D)}{0.3 I_{OUT} f_{sw}}$$

Note that the peak inductor current is the DC output current plus half the ripple current and reaches its highest level at lowest duty cycle (or highest V_{IN}). It is recommended that the inductor should have a saturation current rating in excess of the current limit level.

Table 3 lists examples of off-the-shelf powdered iron and ferrite based inductors that are suitable for use with the LM2854. The output capacitor can be of ceramic or electrolytic chemistry. The chosen output capacitor requires sufficient DC voltage rating and RMS ripple current handling capability.

The output capacitor RMS current and peak-to-peak output ripple are given respectively by

$$I_{Cout(RMS)} = \frac{\Delta i_L}{\sqrt{12}}$$

$$\Delta V_{OUT} = \Delta i_L \sqrt{R_{ESR}^2 + \left(\frac{1}{8f_{sw}C_o}\right)^2}$$

In general, 22 μF to 100 μF of ceramic output capacitance is sufficient for both LM2854 frequency options given the optimal high frequency characteristics and low ESR of ceramic dielectric. It is advisable to consult the manufacturer's derating curves for capacitance voltage coefficient as the in-circuit capacitance may drop significantly with applied voltage.

Tantalum or organic polymer electrolytic capacitance may be suitable with the LM2854 500 kHz option, particularly in applications where substantial bulk capacitance per unit volume is required. However, the high loop bandwidth achievable with the LM2854 obviates the necessity for large bulk capacitance during transient loading conditions.

Table 4 lists some examples of commercially available capacitors that can be used with the LM2854.

TABLE 1. LM2854 500 kHz Compensation Component Values

V_{IN} (V)	L_o (μH)	C_o (μF)		ESR (m Ω)		R_{FB1} (k Ω)	C_{COMP} (pF)	R_{COMP} (k Ω)
		Min	Max	Min	Max			
5.0	1.5	40	100	2	10	150	47	1
	1.5	100	200	1	5	150	100	1
	1.5	100	220	15	25	150	120	25
	2.2	40	100	2	10	150	68	1
	2.2	100	200	1	5	150	120	1
	2.2	100	220	15	25	120	120	15
3.3	1.5	40	100	2	10	150	68	1
	1.5	100	200	1	5	100	150	1
	1.5	100	220	15	25	100	150	15
	2.2	40	100	2	10	150	100	1
	2.2	100	200	1	5	100	220	1
	2.2	100	220	15	25	100	220	10

TABLE 2. LM2854 1 MHz Compensation Component Values

V_{IN} (V)	L_O (μ H)	C_O (μ F)		ESR ($m\Omega$)		R_{FB1} (k Ω)	C_{COMP} (pF)	R_{COMP} (k Ω)
		Min	Max	Min	Max			
5.0	0.68	20	60	2	10	120	33	1
	0.68	60	150	1	5	75	100	1
	0.68	100	220	15	25	100	100	20
	1.0	20	60	2	10	100	56	1
	1.0	60	150	1	5	75	150	1
	1.0	100	220	15	25	75	150	15
3.3	0.68	20	60	2	10	75	56	1
	0.68	60	150	1	5	50	150	1
	0.68	100	220	15	25	50	150	12
	1.0	20	60	2	10	75	82	1
	1.0	60	150	1	5	50	220	1
	1.0	100	220	15	25	33	330	10

TABLE 3. Recommended Filter Inductors

Inductance (μ H)	DCR ($m\Omega$)	Manufacturer	Manufacturer P/N	Case Size (mm)
0.47	14.5	Vishay Dale	IHLP1616BZERR47M11	4.06 x 4.45 x 2.00
1.0	24.0	Vishay Dale	IHLP1616BZER1R0M11	4.06 x 4.45 x 2.00
0.47	8.4	Vishay Dale	IHLP2525AHERR47M01	6.47 x 6.86 x 1.80
0.47	6.0	Vishay Dale	IHLP2525BDERR47M01	6.47 x 6.86 x 2.40
0.68	8.7	Vishay Dale	IHLP2525BDERR68M01	6.47 x 6.86 x 2.40
0.82	10.6	Vishay Dale	IHLP2525BDERR82M01	6.47 x 6.86 x 2.40
1.0	13.1	Vishay Dale	IHLP2525BDER1R0M01	6.47 x 6.86 x 2.40
1.5	18.5	Vishay Dale	IHLP2525BDER1R5M01	6.47 x 6.86 x 2.40
2.2	15.7	Vishay Dale	IHLP2525CZER2R2M11	6.47 x 6.86 x 3.00
0.47	3.5	Sumida	CDMC6D28NP-R47M	6.50 x 7.25 x 3.00
0.68	4.5	Sumida	CDMC6D28NP-R68M	6.50 x 7.25 x 3.00
1.0	17.3	Sumida	CDMC6D28NP-1R0M	6.50 x 7.25 x 3.00
1.5	10.4	Sumida	CDMC6D28NP-1R5M	6.50 x 7.25 x 3.00
2.2	16.1	Sumida	CDMC6D28NP-2R2M	6.50 x 7.25 x 3.00
0.56	10	Coilcraft	DO1813H-561ML	6.10 x 8.89 x 5.00
0.47	3.3	Coilcraft	HA3619-471ALC	7.0 x 7.0 x 3.0
0.68	4.8	Coilcraft	HA3619-681ALC	7.0 x 7.0 x 3.0
1.0	7.5	Coilcraft	HA3619-102ALC	7.0 x 7.0 x 3.0
1.2	9.4	Coilcraft	HA3619-122ALC	7.0 x 7.0 x 3.0
1.5	11.5	Coilcraft	HA3619-152ALC	7.0 x 7.0 x 3.0
1.8	16.5	Coilcraft	HA3619-182ALC	7.0 x 7.0 x 3.0
0.47	3.3	TDK	SPM6530T-R47M170	7.1 x 6.5 x 3.0
0.68	4.9	TDK	SPM6530T-R68M140	7.1 x 6.5 x 3.0
1.0	7.1	TDK	SPM6530T-1R0M120	7.1 x 6.5 x 3.0
1.5	9.7	TDK	SPM6530T-1R5M100	7.1 x 6.5 x 3.0
0.47	14	Cyntec	PCMC042T-0R47MN	4.0 x 4.5 x 2.0
1.0	9	Cyntec	PCMC063T-1R0MN	6.5 x 6.9 x 3.0
1.5	14	Cyntec	PCMC063T-1R5MN	6.5 x 6.9 x 3.0

TABLE 4. Recommended Filter Capacitors

Capacitance (μF)	Voltage (V), ESR ($\text{m}\Omega$)	Chemistry	Manufacturer	Manufacturer P/N	Case Size
22	6.3, < 5	Ceramic, X5R	TDK	C3216X5R0J226M	1206
47	6.3, < 5	Ceramic, X5R	TDK	C3216X5R0J476M	1206
47	6.3, < 5	Ceramic, X5R	TDK	C3225X5R0J476M	1210
47	10.0, < 5	Ceramic, X5R	TDK	C3225X5R1A476M	1210
100	6.3, < 5	Ceramic, X5R	TDK	C3225X5R0J107M	1210
100	6.3, 50	Tantalum	AVX	TPSD157M006#0050	D, 7.5 x 4.3 x 2.9 mm
100	6.3, 25	Organic Polymer	Sanyo	6TPE100MPB2	B2, 3.5 x 2.8 x 1.9 mm
150	6.3, 18	Organic Polymer	Sanyo	6TPE150MIC2	C2, 6.0 x 3.2 x 1.8 mm
330	6.3, 18	Organic Polymer	Sanyo	6TPE330MIL	D3L, 7.3 x 4.3 x 2.8 mm
470	6.3, 23	Niobium Oxide	AVX	NOME37M006#0023	E, 7.3 x 4.3 x 4.1 mm

PC Board Layout Guidelines

PC board layout is an important part of DC-DC converter design. Poor board layout can disrupt the performance of a DC-DC converter and surrounding circuitry by contributing to EMI, ground bounce and resistive voltage drop in the traces. These can send erroneous signals to the DC-DC converter resulting in poor regulation or instability. Good layout can be implemented by following a few simple design rules.

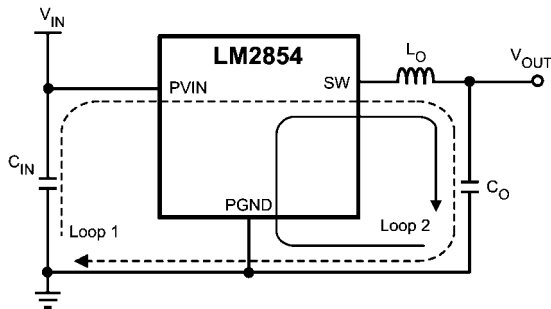

30052853

1. Minimize area of switched current loops.

There are two loops where currents are switched at high di/dt slew rates in a buck regulator. The first loop represents the path taken by AC current flowing during the high side PFET on time. This current flows from the input capacitor to the regulator PVIN pins, through the high side FET to the regulator SW pin, filter inductor, output capacitor and returning via the PCB ground plane to the input capacitor.

The second loop represents the path taken by AC current flowing during the low side NFET on time. This current flows from the output capacitor ground to the regulator PGND pins, through the NFET to the inductor and output capacitor. From an EMI reduction standpoint, it is imperative to minimize this loop area during PC board layout by physically locating the input capacitor close to the LM2854. Specifically, it is advantageous to place C_{IN} as close as possible to the LM2854 PVIN and PGND pins. Grounding for both the input and output capacitor should consist of a localized top side plane that connects to PGND and the exposed die attach pad (DAP). The inductor should be placed close to the SW pin and output capacitor.

2. Minimize the copper area of the switch node.

The LM2854 has two SW pins optimally located on one side of the package. In general the SW pins should be connected to the filter inductor on the top PCB layer. The inductor should be placed close to the SW pins to minimize the copper area of the switch node.

3. Have a single point ground for all device analog grounds located under the DAP.

The ground connections for the Feedback, Soft-start, Enable and AVIN components should be routed to the AGND pin of the device. The AGND pin should connect to PGND under the DAP. This prevents any switched or load currents from flowing in the analog ground traces. If not properly handled, poor grounding can result in degraded load regulation or erratic switching behavior.

4. Minimize trace length to the FB pin.

Since the feedback (FB) node is high impedance, the trace from the output voltage setpoint resistor divider to FB pin should be as short as possible. This is most important as relatively high value resistors are used to set the output voltage. The FB trace should be routed away from the SW pin and inductor to avoid noise pickup from the SW pin. Both feedback resistors, R_{FB1} and R_{FB2} , and the compensation components, R_{COMP} and C_{COMP} , should be located close to the FB pin.

5. Make input and output bus connections as wide as possible.

This reduces any voltage drops on the input or output of the converter and maximizes efficiency. To optimize voltage accuracy at the load, ensure that a separate feedback voltage sense trace is made to the load. Doing so will correct for voltage drops and provide optimum output accuracy.

6. Provide adequate device heat-sinking.

Use an array of heat-sinking vias to connect the DAP to the ground plane on the bottom PCB layer. If the PCB has a plurality of copper layers, these thermal vias can also be employed to make connection to inner layer heat-spreading ground planes. For best results use a 5 x 3 via array with minimum via diameter of 10 mils. Ensure enough copper area is used to keep the junction temperature below 125°C.

LM2854 Application Circuit Schematic and BOMs

This section provides several application solutions with an associated bill of materials. All bill of materials reference the schematic below. The compensation for each solution was optimized to work over the full input range. Many applications

have a fixed input voltage rail. It is possible to modify the compensation to obtain a faster transient response for a given input voltage operating point.

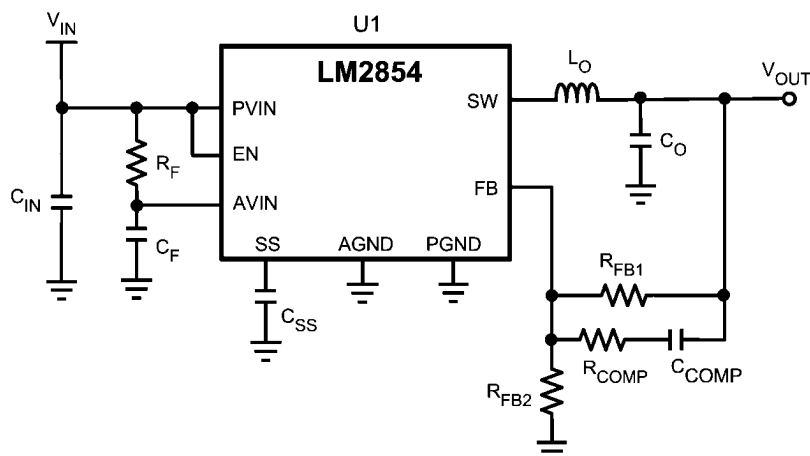

30052854

TABLE 5. LM2854 500kHz Bill of Materials, $V_{IN} = 5V$, $V_{OUT} = 3.3V$, $I_{OUT(MAX)} = 4A$, Optimized for Efficiency

Ref Des	Description	Case Size	Manufacturer	Manufacturer P/N
U1	Synchronous Buck Regulator	eTSSOP-16	National Semiconductor	LM2854MHX-500
C_{IN}	47 μF , X5R, 10V	1210	TDK	C3225X5R1A476M
C_O	100 μF , X5R, 6.3V	1210	TDK	C3225X5R0J107M
L_O	1.5 μH , 9.7 m Ω , 10A	7.1 x 6.5 x 3.0 mm	TDK	SPM6530T-1R5M100
R_{FB1}	249 k Ω	0603	Vishay Dale	CRCW06032493F-e3
R_{FB2}	80.6 k Ω	0603	Vishay Dale	CRCW060328062F-e3
R_{COMP}	1.0 k Ω	0603	Vishay Dale	CRCW06031001F-e3
R_F	1.0 Ω	0603	Vishay Dale	CRCW06031R0F-e3
C_{COMP}	33 pF, $\pm 5\%$, C0G, 50V	0603	TDK	C1608C0G1H330J
C_{SS}	10 nF, $\pm 10\%$, X7R, 16V	0603	Murata	GRM188R71C103KA01
C_F	1.0 μF , $\pm 10\%$, X7R, 10V	0603	Murata	GRM188R71A105KA61

TABLE 6. LM2854 1 MHz Bill of Materials, $V_{IN} = 3.3V$ to $5V$, $V_{OUT} = 2.5V$, $I_{OUT(MAX)} = 4A$, Optimized for Electrolytic Input and Output Capacitance

Ref Des	Description	Case Size	Manufacturer	Manufacturer P/N
U1	Synchronous Buck Regulator	eTSSOP-16	National Semiconductor	LM2854MHX-1000
C_{IN}	150 μF , 6.3V, 18 m Ω	C2, 6.0 x 3.2 x 1.8 mm	Sanyo	6TPE150MIC2
C_O	330 μF , 6.3V, 18 m Ω	D3L, 7.3 x 4.3 x 2.8 mm	Sanyo	6TPE330MIL
L_O	2.2 μH , 16 m Ω , 7A	6.47 x 6.86 x 3.00 mm	Vishay Dale	IHLP2525CZER2R2M11
R_{FB1}	100 k Ω	0603	Vishay Dale	CRCW06031003F-e3
R_{FB2}	47.5 k Ω	0603	Vishay Dale	CRCW060324752F-e3
R_{COMP}	15 k Ω	0603	Vishay Dale	CRCW06031502F-e3
R_F	1.0 Ω	0603	Vishay Dale	CRCW06031R0F-e3
C_{COMP}	330 pF, $\pm 5\%$, C0G, 50V	0603	TDK	C1608C0G1H331J
C_{SS}	10 nF, $\pm 10\%$, X7R, 16V	0603	Murata	GRM188R71C103KA01
C_F	1.0 μF , $\pm 10\%$, X7R, 10V	0603	Murata	GRM188R71A105KA61

TABLE 7. LM2854 1 MHz Bill of Materials, $V_{IN} = 3.3V$, $V_{OUT} = 0.8V$, $I_{OUT(MAX)} = 4A$, Optimized for Solution Size and Transient Response

Ref Des	Description	Case Size	Manufacturer	Manufacturer P/N
U1	Synchronous Buck Regulator	eTSSOP-16	National Semiconductor	LM2854MHX-1000
C_{IN}	47 μF , X5R, 6.3V	1206	TDK	C3216X5R0J476M
C_O	47 μF , X5R, 6.3V	1206	TDK	C3216X5R0J476M
L_O	0.47 μH , 14.5 m Ω , 7A	4.06 x 4.45 x 2.00 mm	Vishay Dale	IHLP1616BZER0R47M11
R_{FB1}	110 k Ω	0402	Vishay Dale	CRCW04021103F-e3
R_{COMP}	1.0 k Ω	0402	Vishay Dale	CRCW04021001F-e3
R_F	1.0 Ω	0402	Vishay Dale	CRCW04021R0F-e3
C_{COMP}	27 pF, $\pm 5\%$, C0G, 50V	0402	Murata	GRM1555C1H270JZ01
C_{SS}	10 nF, $\pm 10\%$, X7R, 16V	0402	Murata	GRM155R71C103KA01
C_F	1.0 μF , $\pm 10\%$, X7R, 10V	0402	Murata	GRM155R61A105KE15

Physical Dimensions inches (millimeters) unless otherwise noted

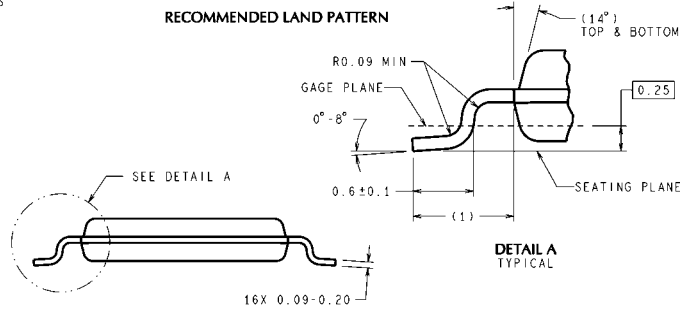
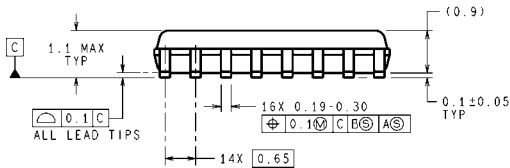
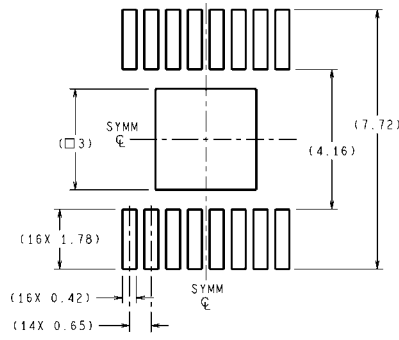
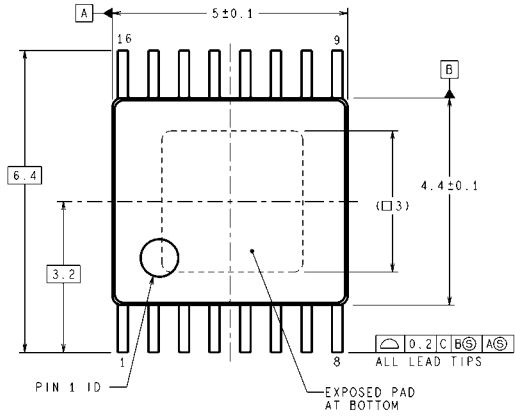

DIMENSIONS ARE IN MILLIMETERS
16-Lead eTSSOP Package
NS Package Number MXA16A

MXA16A (Rev A)

Notes

For more National Semiconductor product information and proven design tools, visit the following Web sites at:

Products		Design Support	
Amplifiers	www.national.com/amplifiers	WEBENCH	www.national.com/webench
Audio	www.national.com/audio	Analog University	www.national.com/AU
Clock Conditioners	www.national.com/timing	App Notes	www.national.com/appnotes
Data Converters	www.national.com/adc	Distributors	www.national.com/contacts
Displays	www.national.com/displays	Green Compliance	www.national.com/quality/green
Ethernet	www.national.com/ethernet	Packaging	www.national.com/packaging
Interface	www.national.com/interface	Quality and Reliability	www.national.com/quality
LVDS	www.national.com/lvds	Reference Designs	www.national.com/refdesigns
Power Management	www.national.com/power	Feedback	www.national.com/feedback
Switching Regulators	www.national.com/switchers		
LDOs	www.national.com/lido		
LED Lighting	www.national.com/led		
PowerWise	www.national.com/powerwise		
Serial Digital Interface (SDI)	www.national.com/sdi		
Temperature Sensors	www.national.com/tempsensors		
Wireless (PLL/VCO)	www.national.com/wireless		

THE CONTENTS OF THIS DOCUMENT ARE PROVIDED IN CONNECTION WITH NATIONAL SEMICONDUCTOR CORPORATION ("NATIONAL") PRODUCTS. NATIONAL MAKES NO REPRESENTATIONS OR WARRANTIES WITH RESPECT TO THE ACCURACY OR COMPLETENESS OF THE CONTENTS OF THIS PUBLICATION AND RESERVES THE RIGHT TO MAKE CHANGES TO SPECIFICATIONS AND PRODUCT DESCRIPTIONS AT ANY TIME WITHOUT NOTICE. NO LICENSE, WHETHER EXPRESS, IMPLIED, ARISING BY ESTOPPEL OR OTHERWISE, TO ANY INTELLECTUAL PROPERTY RIGHTS IS GRANTED BY THIS DOCUMENT.

TESTING AND OTHER QUALITY CONTROLS ARE USED TO THE EXTENT NATIONAL DEEMS NECESSARY TO SUPPORT NATIONAL'S PRODUCT WARRANTY. EXCEPT WHERE MANDATED BY GOVERNMENT REQUIREMENTS, TESTING OF ALL PARAMETERS OF EACH PRODUCT IS NOT NECESSARILY PERFORMED. NATIONAL ASSUMES NO LIABILITY FOR APPLICATIONS ASSISTANCE OR BUYER PRODUCT DESIGN. BUYERS ARE RESPONSIBLE FOR THEIR PRODUCTS AND APPLICATIONS USING NATIONAL COMPONENTS. PRIOR TO USING OR DISTRIBUTING ANY PRODUCTS THAT INCLUDE NATIONAL COMPONENTS, BUYERS SHOULD PROVIDE ADEQUATE DESIGN, TESTING AND OPERATING SAFEGUARDS.

EXCEPT AS PROVIDED IN NATIONAL'S TERMS AND CONDITIONS OF SALE FOR SUCH PRODUCTS, NATIONAL ASSUMES NO LIABILITY WHATSOEVER, AND NATIONAL DISCLAIMS ANY EXPRESS OR IMPLIED WARRANTY RELATING TO THE SALE AND/OR USE OF NATIONAL PRODUCTS INCLUDING LIABILITY OR WARRANTIES RELATING TO FITNESS FOR A PARTICULAR PURPOSE, MERCHANTABILITY, OR INFRINGEMENT OF ANY PATENT, COPYRIGHT OR OTHER INTELLECTUAL PROPERTY RIGHT.

LIFE SUPPORT POLICY

NATIONAL'S PRODUCTS ARE NOT AUTHORIZED FOR USE AS CRITICAL COMPONENTS IN LIFE SUPPORT DEVICES OR SYSTEMS WITHOUT THE EXPRESS PRIOR WRITTEN APPROVAL OF THE CHIEF EXECUTIVE OFFICER AND GENERAL COUNSEL OF NATIONAL SEMICONDUCTOR CORPORATION. As used herein:

Life support devices or systems are devices which (a) are intended for surgical implant into the body, or (b) support or sustain life and whose failure to perform when properly used in accordance with instructions for use provided in the labeling can be reasonably expected to result in a significant injury to the user. A critical component is any component in a life support device or system whose failure to perform can be reasonably expected to cause the failure of the life support device or system or to affect its safety or effectiveness.

National Semiconductor and the National Semiconductor logo are registered trademarks of National Semiconductor Corporation. All other brand or product names may be trademarks or registered trademarks of their respective holders.

Copyright© 2008 National Semiconductor Corporation

For the most current product information visit us at www.national.com



**National Semiconductor
Americas Technical
Support Center**
Email:
new.feedback@nsc.com
Tel: 1-800-272-9959

**National Semiconductor Europe
Technical Support Center**
Email: europe.support@nsc.com
German Tel: +49 (0) 180 5010 771
English Tel: +44 (0) 870 850 4288

**National Semiconductor Asia
Pacific Technical Support Center**
Email: ap.support@nsc.com

**National Semiconductor Japan
Technical Support Center**
Email: jpn.feedback@nsc.com