

1.8-V MICROPPOWER CMOS OPERATIONAL AMPLIFIER ZERO-DRIFT SERIES

 Check for Samples: [OPA2333-Q1](#)

FEATURES

- Qualified for Automotive Applications
- Low Offset Voltage: 23 μV (Max)
- 0.01-Hz to 10-Hz Noise: 1.1 μV_{PP}
- Quiescent Current: 17 μA
- Single-Supply Operation
- Supply Voltage: 1.8 V to 5.5 V
- Rail-to-Rail Input/Output

APPLICATIONS

- Transducer Applications
- Temperature Measurements
- Electronic Scales
- Medical Instrumentation
- Battery-Powered Instruments
- Handheld Test Equipment

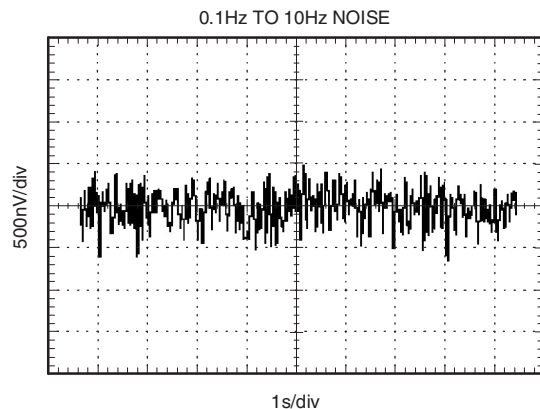
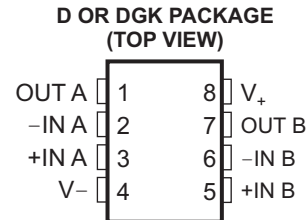

DESCRIPTION/ORDERING INFORMATION

The OPA2333A CMOS operational amplifiers use a proprietary auto-calibration technique to simultaneously provide very low offset voltage (10 μV max) and near-zero drift over time and temperature. These miniature high-precision low-quiescent-current amplifiers offer high-impedance inputs that have a common-mode range 100 mV beyond the rails and rail-to-rail output that swings within 50 mV of the rails. Single or dual supplies as low as 1.8 V (± 0.9 V) and up to 5.5 V (± 2.75 V) may be used. They are optimized for low-voltage single-supply operation.

The OPA2333A offers excellent common-mode rejection ratio (CMRR) without the crossover associated with traditional complementary input stages. This design results in superior performance for driving analog-to-digital converters (ADCs) without degradation of differential linearity.

The OPA2333A is specified for operation from -40°C to 125°C .

ORDERING INFORMATION⁽¹⁾

T _A	PACKAGE ⁽²⁾		ORDERABLE PART NUMBER	TOP-SIDE MARKING
-40°C to 125°C	SOIC – D	Reel of 2500	OPA2333AQDRQ1	02333Q
	MSOP – DGK	Reel of 2500	OPA2333AQDGKRQ1	OCOQ

(1) For the most current package and ordering information, see the Package Option Addendum at the end of this document, or see the TI web site at www.ti.com.

(2) Package drawings, thermal data, and symbolization are available at www.ti.com/packaging.



Please be aware that an important notice concerning availability, standard warranty, and use in critical applications of Texas Instruments semiconductor products and disclaimers thereto appears at the end of this data sheet.

ABSOLUTE MAXIMUM RATINGS⁽¹⁾

over operating free-air temperature range (unless otherwise noted)

V _{CC}	Supply voltage		7 V
V _I	Input voltage, signal input terminals ⁽²⁾		–0.3 V to (V+) + 0.3
I _{O(SS)}	Output short-circuit current ⁽³⁾		Continuous
T _A	Operating free-air temperature range		–40°C to 125°C
T _J	Maximum operating virtual-junction temperature		150°C
T _{stg}	Storage temperature range		–65°C to 150°C
ESD	Electrostatic discharge (ESD) rating	Human-Body Model (HBM)	2000 V
		Charged-Device Model (CDM)	1000 V

- (1) Stresses beyond those listed under *absolute maximum ratings* may cause permanent damage to the device. These are stress ratings only, and functional operation of the device at these or any other conditions beyond those indicated under *recommended operating conditions* is not implied. Exposure to absolute-maximum-rated conditions for extended periods may affect device reliability.
- (2) Input terminals are diode clamped to the power-supply rails. Input signals that can swing more than 0.3 V beyond the supply rails should be current limited to 10 mA or less.
- (3) Short circuit to ground, one amplifier per package

ELECTRICAL CHARACTERISTICS: V_S = 1.8 V to 5.5 V

Boldface limits apply over the specified temperature range, T_A = –40°C to 125°C. At T_A = 25°C, R_L = 10 kΩ connected to V_S/2, V_{CM} = V_S/2, and V_{OUT} = V_S/2 (unless otherwise noted).

PARAMETER	TEST CONDITIONS	MIN	TYP	MAX	UNIT
OFFSET VOLTAGE					
Input offset voltage	V _{OS}		2	10	μV
over temperature				22	μV
vs temperature	dV _{OS} /dT		0.02		μV/°C
vs power supply	PSRR	V _S = 1.8 V to 5.5 V	1	6	μV/V
Long-term stability ⁽¹⁾			(1)		
Channel separation, dc			0.1		μV/V
INPUT BIAS CURRENT					
Input bias current	I _B		±70	±200	pA
over Temperature			±150		pA
Input offset current	I _{OS}		±140	±400	pA
NOISE					
Input voltage noise, f = 0.01 Hz to 1 Hz			0.3		μV _{PP}
Input voltage noise, f = 0.1 Hz to 10 Hz			1.1		μV _{PP}
Input current noise, f = 10 Hz	i _n		100		fA/√Hz
INPUT VOLTAGE RANGE					
Common mode voltage range	V _{CM}	(V–) – 0.1		(V+) + 0.1	V
Common-Mode Rejection Ratio	CMRR	(V–) – 0.1 V < V _{CM} < (V+) + 0.1 V	102	130	dB
INPUT CAPACITANCE					
Differential			2		pF
Common mode			4		pF
OPEN-LOOP GAIN					
Open-loop voltage gain	A _{OL}	(V–) + 100 mV < V _O < (V+) – 100 mV, R _L = 10 kΩ	104	130	dB
FREQUENCY RESPONSE					
Gain-bandwidth product	GBW	C _L = 100 pF	350		kHz
Slew rate	SR	G = 1	0.16		V/μs

- (1) 300-hour life test at 150°C demonstrated randomly distributed variation of approximately 1 μV.

ELECTRICAL CHARACTERISTICS: $V_S = 1.8\text{ V to }5.5\text{ V}$ (continued)

Boldface limits apply over the specified temperature range, $T_A = -40^\circ\text{C to }125^\circ\text{C}$. At $T_A = 25^\circ\text{C}$, $R_L = 10\text{ k}\Omega$ connected to $V_S/2$, $V_{CM} = V_S/2$, and $V_{OUT} = V_S/2$ (unless otherwise noted).

PARAMETER	TEST CONDITIONS	MIN	TYP	MAX	UNIT
OUTPUT					
Voltage output swing from rail	$R_L = 10\text{ k}\Omega$		30	50	mV
over temperature	$R_L = 10\text{ k}\Omega$			85	mV
Short-circuit current	ISC		± 5		mA
Capacitive load drive	CL				
⁽²⁾ Open-loop output impedance	$f = 350\text{ kHz}, I_O = 0$		2		k Ω
POWER SUPPLY					
Specified voltage range	V_S	1.8		5.5	V
Quiescent current per amplifier	I_Q		17	25	μA
over temperature				30	μA
Turn-on time	$V_S = 5\text{ V}$		100		μs
TEMPERATURE RANGE					
Specified range		-40		125	$^\circ\text{C}$
Operating range		-40		125	$^\circ\text{C}$
Storage range		-65		150	$^\circ\text{C}$
Thermal resistance	θ_{JA}		150		$^\circ\text{C/W}$
			172.47		$^\circ\text{C/W}$
	SO-8 (D)				
	MSOP-8 (DGK)				

(2) See *Typical Characteristics*.

TYPICAL CHARACTERISTICS

At $T_A = 25^\circ\text{C}$, $V_S = 5\text{ V}$, and $C_L = 0\text{ pF}$ (unless otherwise noted)

OFFSET VOLTAGE PRODUCTION DISTRIBUTION

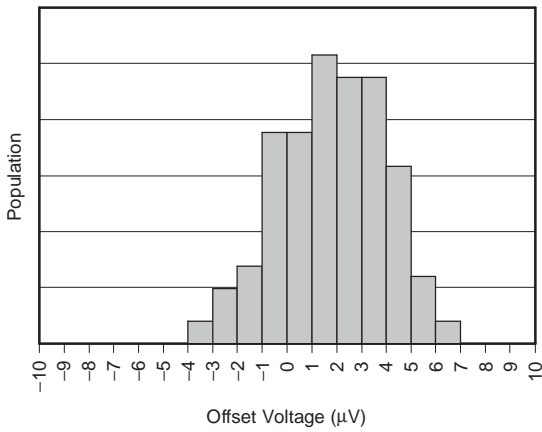

OFFSET VOLTAGE DRIFT PRODUCTION DISTRIBUTION

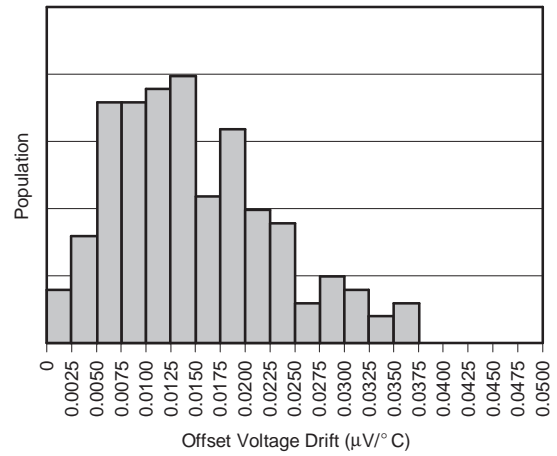

OPEN-LOOP GAIN vs FREQUENCY

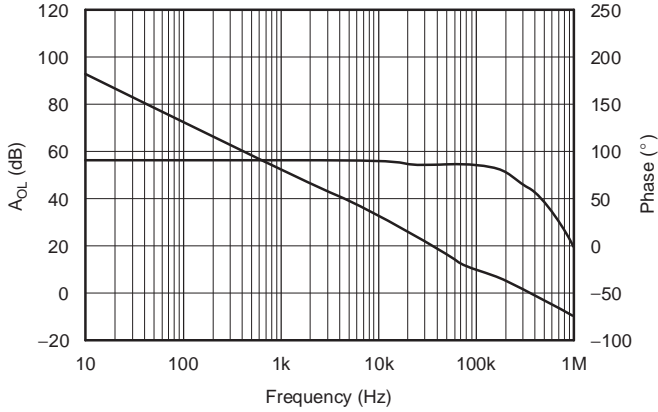

COMMON-MODE REJECTION RATIO vs FREQUENCY

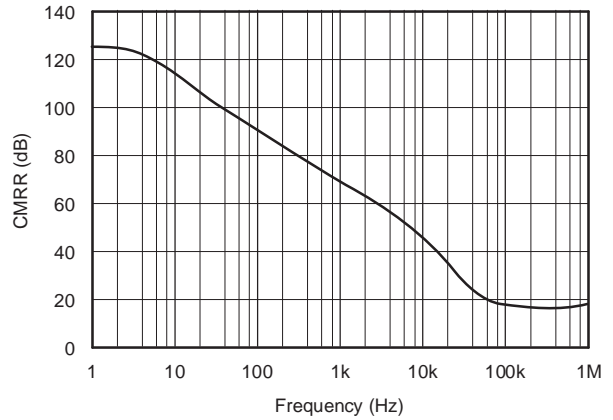

POWER-SUPPLY REJECTION RANGE vs FREQUENCY

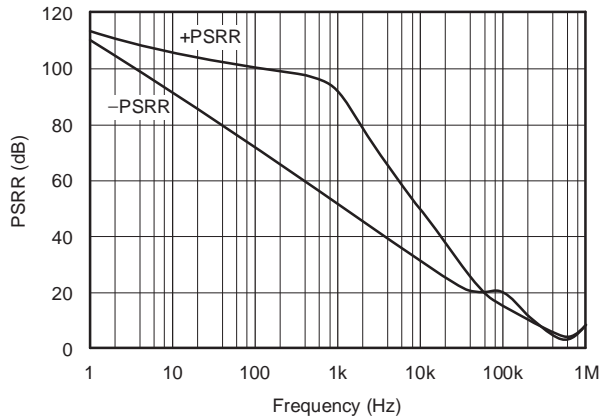

OUTPUT VOLTAGE SWING vs OUTPUT CURRENT

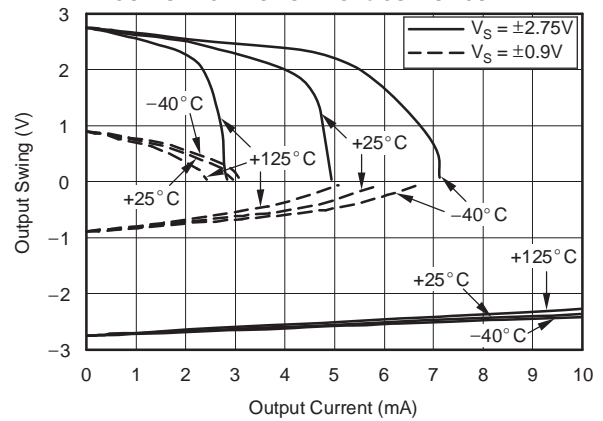

TYPICAL CHARACTERISTICS (continued)

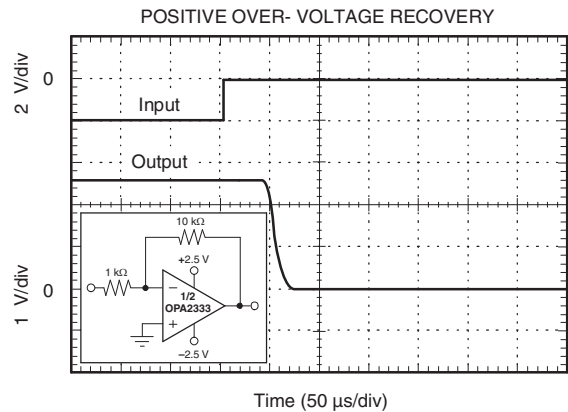
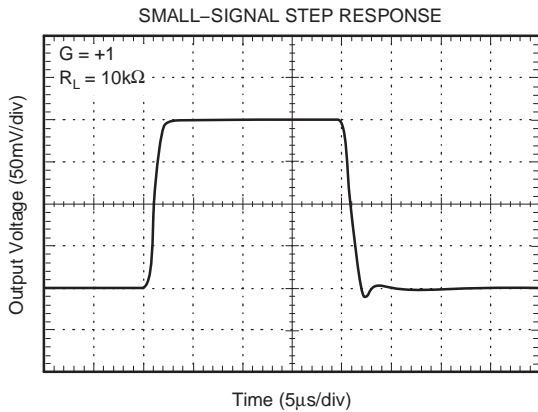
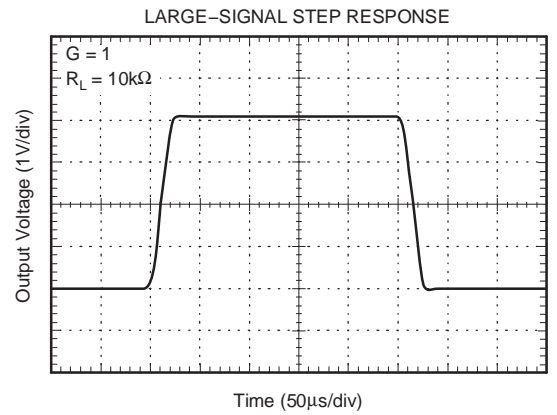
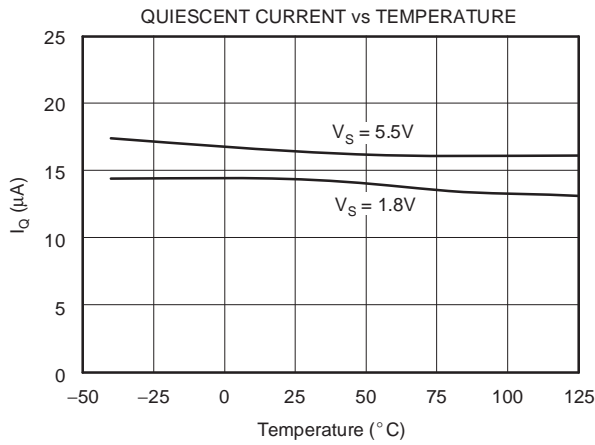
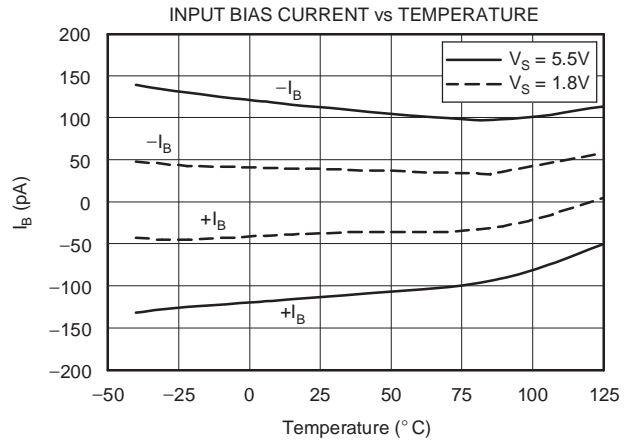
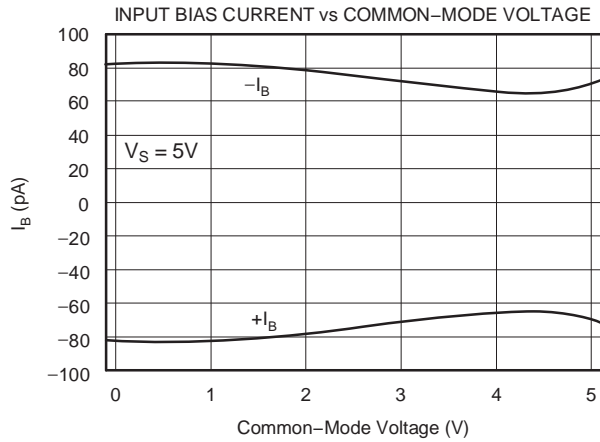

TYPICAL CHARACTERISTICS (continued)

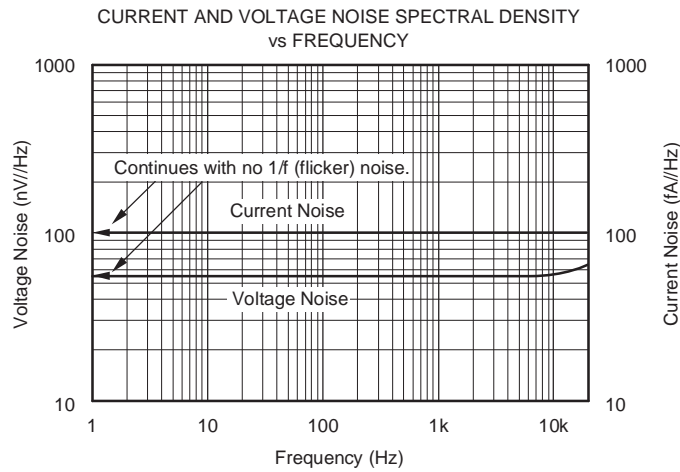
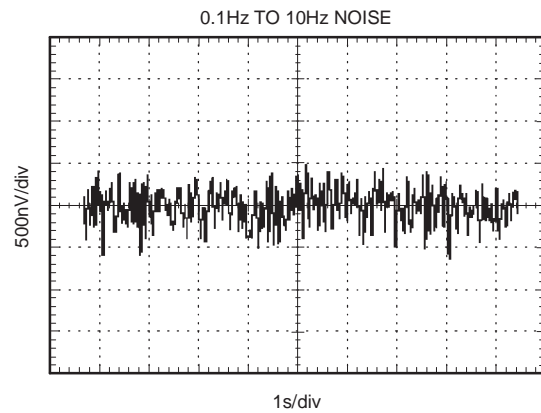
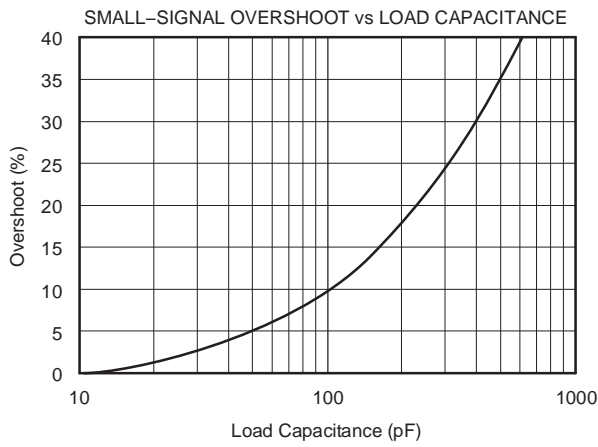
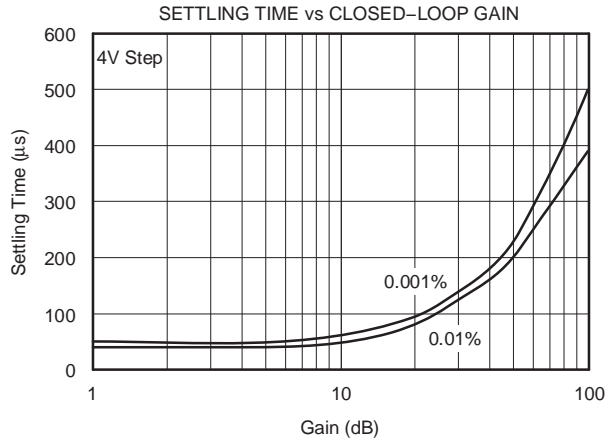
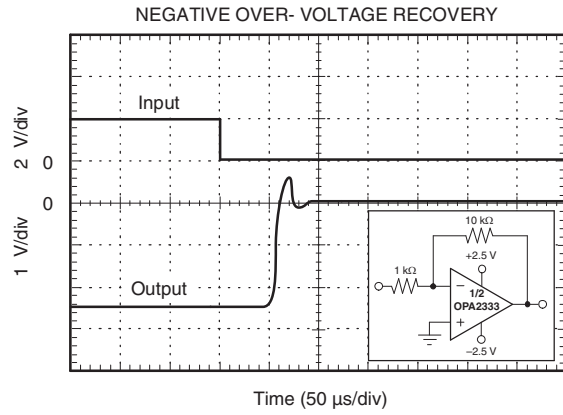

APPLICATION INFORMATION

The OPA2333A op amps are unity-gain stable and free from unexpected output phase reversal. They use a proprietary auto-calibration technique to provide low offset voltage and very low drift over time and temperature. For lowest offset voltage and precision performance, circuit layout and mechanical conditions should be optimized. Avoid temperature gradients that create thermoelectric (Seebeck) effects in the thermocouple junctions formed from connecting dissimilar conductors. These thermally-generated potentials can be made to cancel by ensuring they are equal on both input terminals. Other layout and design considerations include:

- Use low thermoelectric-coefficient conditions (avoid dissimilar metals)
- Thermally isolate components from power supplies or other heat sources
- Shield op amp and input circuitry from air currents, such as cooling fans

Following these guidelines will reduce the likelihood of junctions being at different temperatures, which can cause thermoelectric voltages of 0.1 $\mu\text{V}/^\circ\text{C}$ or higher, depending on materials used.

Operating Voltage

The OPA2333A op amps operate over a power-supply range of 1.8 V to 5.5 V (± 0.9 V to ± 2.75 V). Supply voltages higher than 7 V (absolute maximum) can permanently damage the device. Parameters that vary over supply voltage or temperature are shown in the Typical Characteristics section of this data sheet.

Input Voltage

The OPA2333A input common-mode voltage range extends 0.1 V beyond the supply rails. The device is designed to cover the full range without the troublesome transition region found in some other rail-to-rail amplifiers.

Normally, input bias current is about 70 pA; however, input voltages exceeding the power supplies can cause excessive current to flow into or out of the input pins. Momentary voltages greater than the power supply can be tolerated if the input current is limited to 10 mA. This limitation is easily accomplished with an input resistor (see [Figure 1](#)).

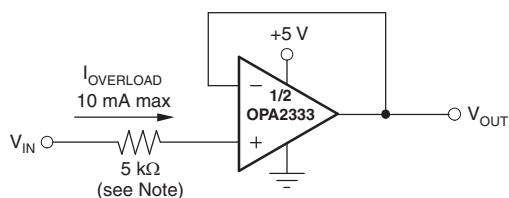

NOTE: Current-limiting resistor required if input voltage exceeds supply rails by ≥ 0.5 V.

Figure 1. Input Current Protection

Internal Offset Correction

The OPA2333A op amps use an auto-calibration technique with a time-continuous 350-kHz op amp in the signal path. This amplifier is zero corrected every 8 μs using a proprietary technique. Upon power up, the amplifier requires approximately 100 μs to achieve specified V_{OS} accuracy. This design has no aliasing or flicker noise.

Achieving Output Swing to the Op Amp Negative Rail

Some applications require output voltage swings from 0 V to a positive full-scale voltage (such as 2.5 V) with excellent accuracy. With most single-supply op amps, problems arise when the output signal approaches 0 V, near the lower output swing limit of a single-supply op amp. A good single-supply op amp may swing close to single-supply ground, but will not reach ground. The output of the OPA2333A can be made to swing to ground or slightly below on a single-supply power source. To do so requires the use of another resistor and an additional, more negative, power supply than the op amp negative supply. A pull-down resistor may be connected between the output and the additional negative supply to pull the output down below the value that the output would otherwise achieve (see [Figure 2](#)).

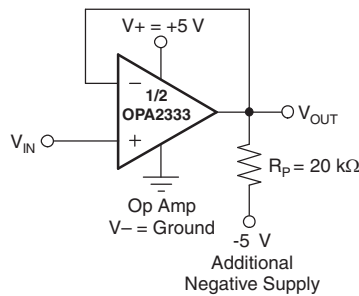

Figure 2. V_{OUT} Range to Ground

The OPA2333A has an output stage that allows the output voltage to be pulled to its negative supply rail, or slightly below, using the technique previously described. This technique only works with some types of output stages. The OPA2333A has been characterized to perform with this technique; however, the recommended resistor value is approximately 20 k Ω . Note that this configuration increases the current consumption by several hundreds of microamps. Accuracy is excellent down to 0 V and as low as -2 mV. Limiting and nonlinearity occurs below -2 mV, but excellent accuracy returns as the output is again driven above -2 mV. Lowering the resistance of the pull-down resistor allows the op amp to swing even further below the negative rail. Resistances as low as 10 k Ω can be used to achieve excellent accuracy down to -10 mV.

General Layout Guidelines

Attention to good layout practices is always recommended. Keep traces short and, when possible, use a printed circuit board (PCB) ground plane with surface-mount components placed as close to the device pins as possible. Place a 0.1- μ F capacitor closely across the supply pins. These guidelines should be applied throughout the analog circuit to improve performance and provide benefits, such as reducing the electromagnetic interference (EMI) susceptibility.

Operational amplifiers vary in their susceptibility to radio frequency interference (RFI). RFI can generally be identified as a variation in offset voltage or dc signal levels with changes in the interfering RF signal. The OPA2333A has been specifically designed to minimize susceptibility to RFI and demonstrates remarkably low sensitivity compared to previous-generation devices. Strong RF fields may still cause varying offset levels.

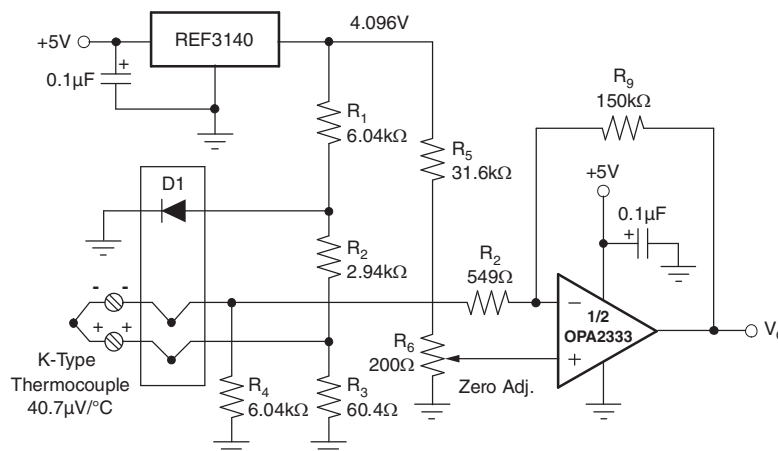

Figure 3. Temperature Measurement

Figure 4 shows the basic configuration for a bridge amplifier.

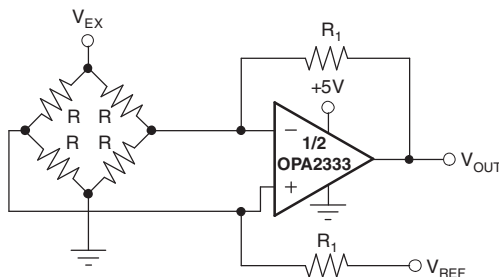
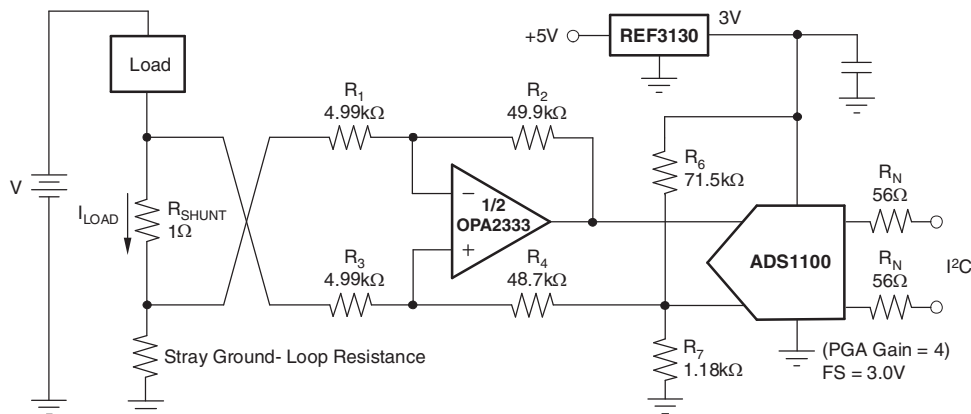

Figure 4. Single Op-Amp Bridge Amplifier

A low-side current shunt monitor is shown in Figure 5. R_N are operational resistors used to isolate the ADS1100 from the noise of the digital I²C bus. Since the ADS1100 is a 16-bit converter, a precise reference is essential for maximum accuracy. If absolute accuracy is not required, and the 5-V power supply is sufficiently stable, the REF3130 may be omitted.



NOTE: 1% resistors provide adequate common-mode rejection at small ground-loop errors.

Figure 5. Low-Side Current Monitor

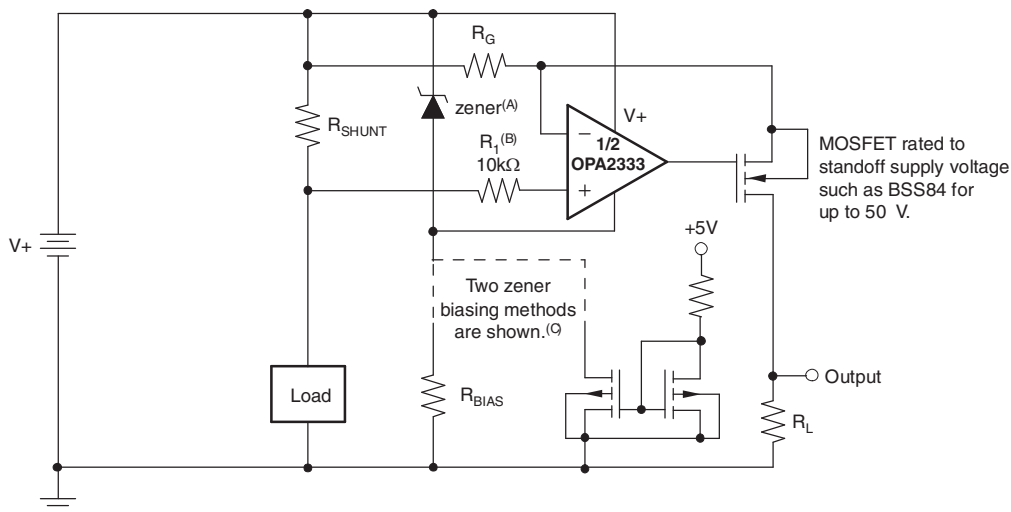

- A. Zener rated for op amp supply capability (that is, 5.1 V for OPA2333).
- B. Current-limiting resistor
- C. Choose Zener biasing resistor or dual NMOSFETs (FDG6301N, NTJD4001N, or Si1034).

Figure 6. High-Side Current Monitor

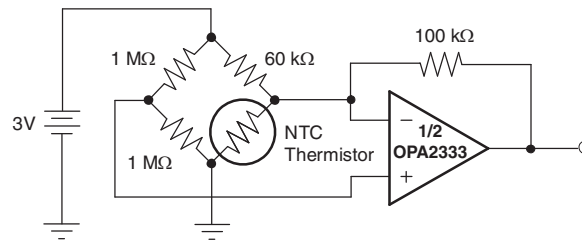

Figure 7. Thermistor Measurement

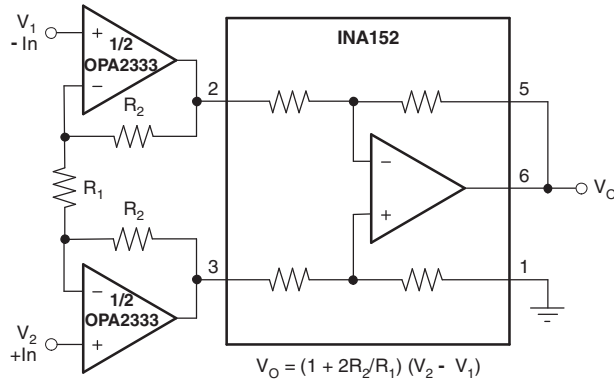
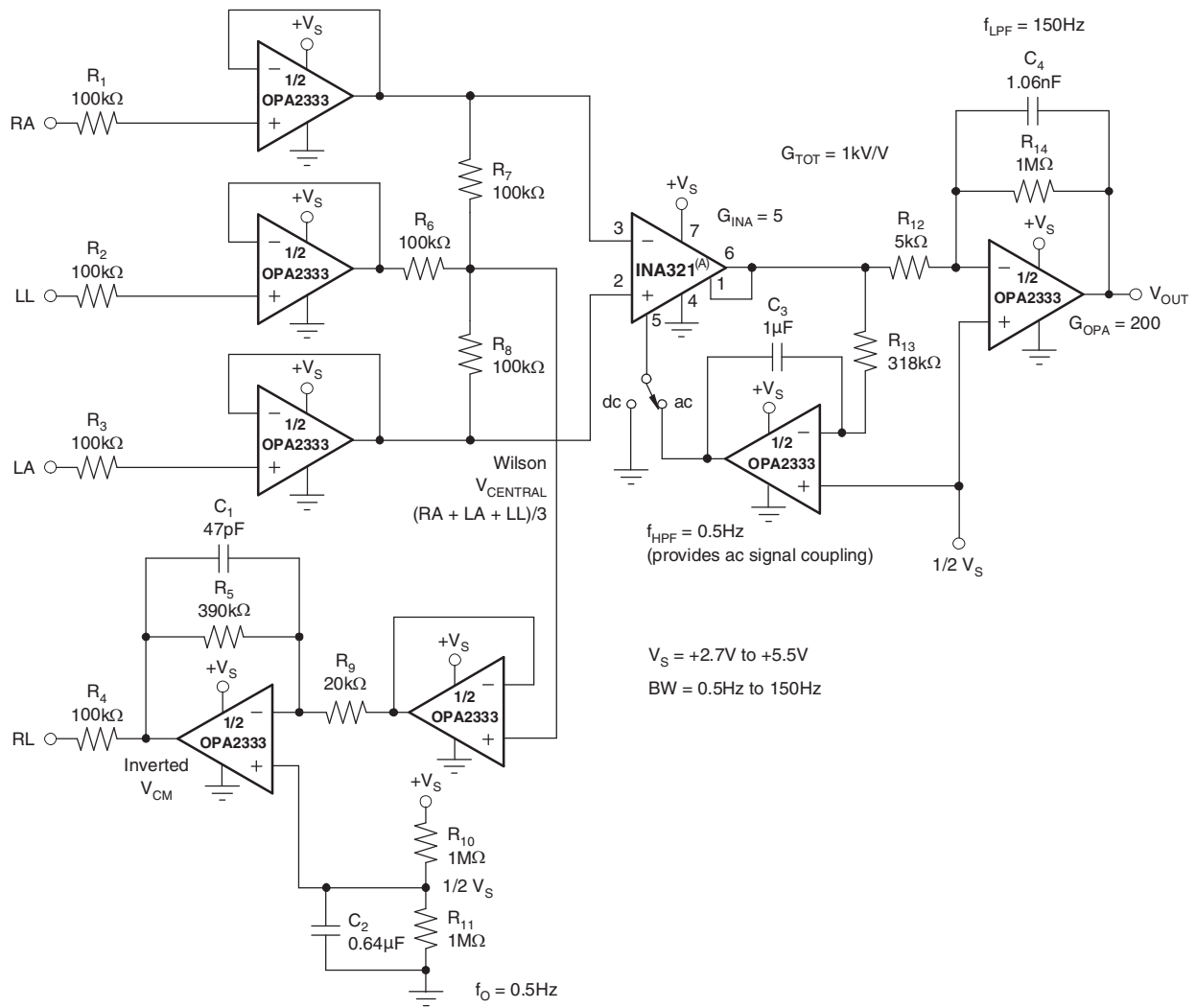

Figure 8. Precision Instrumentation Amplifier



- A. Other instrumentation amplifiers can be used, such as the INA326, which has lower noise, but higher quiescent current.

Figure 9. Single-Supply, Very-Low-Power ECG Circuit

PACKAGING INFORMATION

Orderable Device	Status ⁽¹⁾	Package Type	Package Drawing	Pins	Package Qty	Eco Plan ⁽²⁾	Lead/ Ball Finish	MSL Peak Temp ⁽³⁾	Samples (Requires Login)
OPA2333AQDGKRQ1	ACTIVE	VSSOP	DGK	8	2500	TBD	Call TI	Call TI	
OPA2333AQDRQ1	ACTIVE	SOIC	D	8	2500	TBD	Call TI	Call TI	

⁽¹⁾ The marketing status values are defined as follows:

ACTIVE: Product device recommended for new designs.

LIFEBUY: TI has announced that the device will be discontinued, and a lifetime-buy period is in effect.

NRND: Not recommended for new designs. Device is in production to support existing customers, but TI does not recommend using this part in a new design.

PREVIEW: Device has been announced but is not in production. Samples may or may not be available.

OBSELETE: TI has discontinued the production of the device.

⁽²⁾ Eco Plan - The planned eco-friendly classification: Pb-Free (RoHS), Pb-Free (RoHS Exempt), or Green (RoHS & no Sb/Br) - please check <http://www.ti.com/productcontent> for the latest availability information and additional product content details.

TBD: The Pb-Free/Green conversion plan has not been defined.

Pb-Free (RoHS): TI's terms "Lead-Free" or "Pb-Free" mean semiconductor products that are compatible with the current RoHS requirements for all 6 substances, including the requirement that lead not exceed 0.1% by weight in homogeneous materials. Where designed to be soldered at high temperatures, TI Pb-Free products are suitable for use in specified lead-free processes.

Pb-Free (RoHS Exempt): This component has a RoHS exemption for either 1) lead-based flip-chip solder bumps used between the die and package, or 2) lead-based die adhesive used between the die and leadframe. The component is otherwise considered Pb-Free (RoHS compatible) as defined above.

Green (RoHS & no Sb/Br): TI defines "Green" to mean Pb-Free (RoHS compatible), and free of Bromine (Br) and Antimony (Sb) based flame retardants (Br or Sb do not exceed 0.1% by weight in homogeneous material)

⁽³⁾ MSL, Peak Temp. -- The Moisture Sensitivity Level rating according to the JEDEC industry standard classifications, and peak solder temperature.

Important Information and Disclaimer: The information provided on this page represents TI's knowledge and belief as of the date that it is provided. TI bases its knowledge and belief on information provided by third parties, and makes no representation or warranty as to the accuracy of such information. Efforts are underway to better integrate information from third parties. TI has taken and continues to take reasonable steps to provide representative and accurate information but may not have conducted destructive testing or chemical analysis on incoming materials and chemicals. TI and TI suppliers consider certain information to be proprietary, and thus CAS numbers and other limited information may not be available for release.

In no event shall TI's liability arising out of such information exceed the total purchase price of the TI part(s) at issue in this document sold by TI to Customer on an annual basis.

OTHER QUALIFIED VERSIONS OF OPA2333-Q1 :

- Catalog: [OPA2333](#)

NOTE: Qualified Version Definitions:

- Catalog - TI's standard catalog product

DGK (S-PDSO-G8)

PLASTIC SMALL-OUTLINE PACKAGE

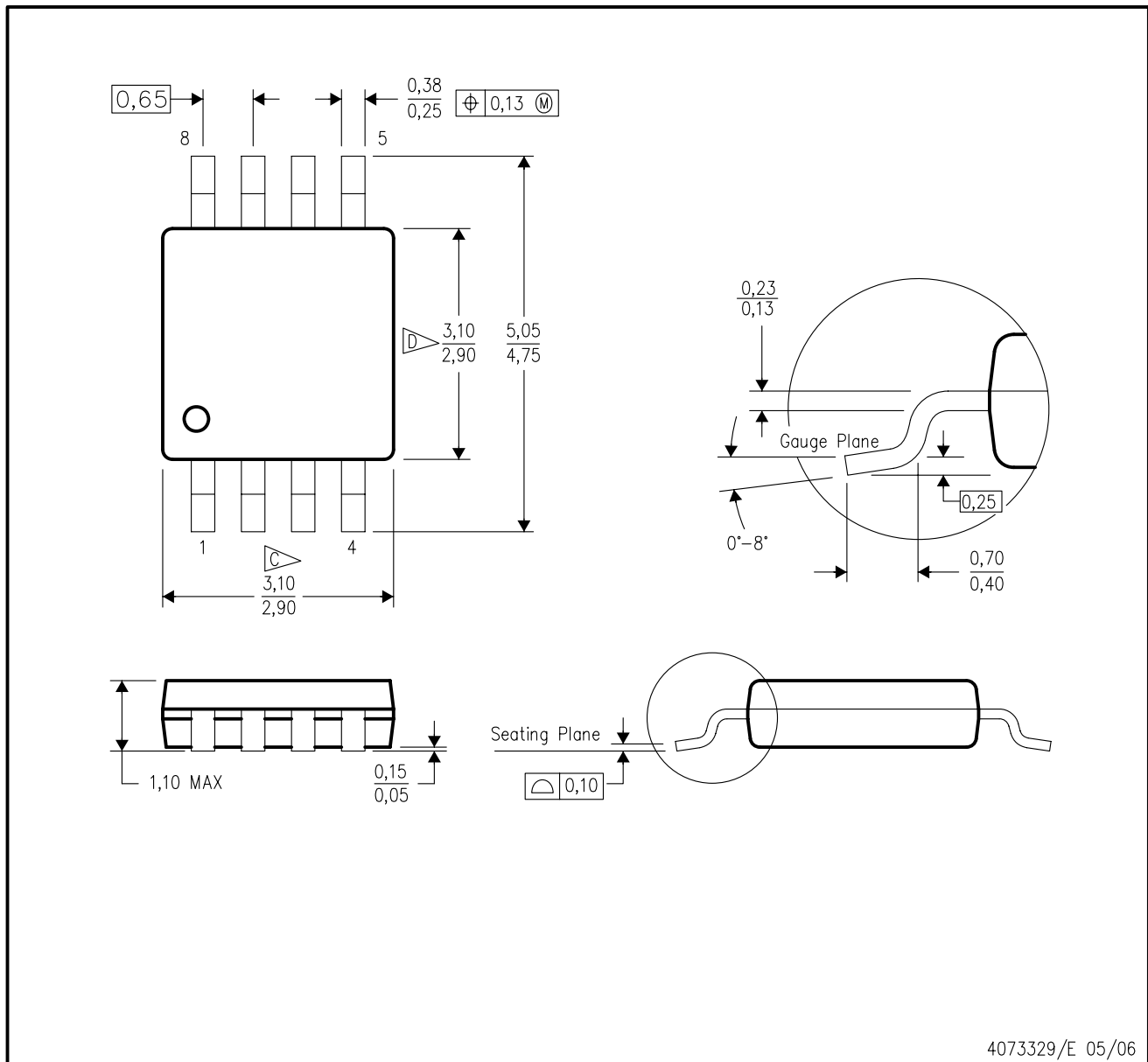

- NOTES:
- A. All linear dimensions are in millimeters.
 - B. This drawing is subject to change without notice.
 - C. Body length does not include mold flash, protrusions, or gate burrs. Mold flash, protrusions, or gate burrs shall not exceed 0.15 per end.
 - D. Body width does not include interlead flash. Interlead flash shall not exceed 0.50 per side.
 - E. Falls within JEDEC MO-187 variation AA, except interlead flash.

D (R-PDSO-G8)

PLASTIC SMALL OUTLINE

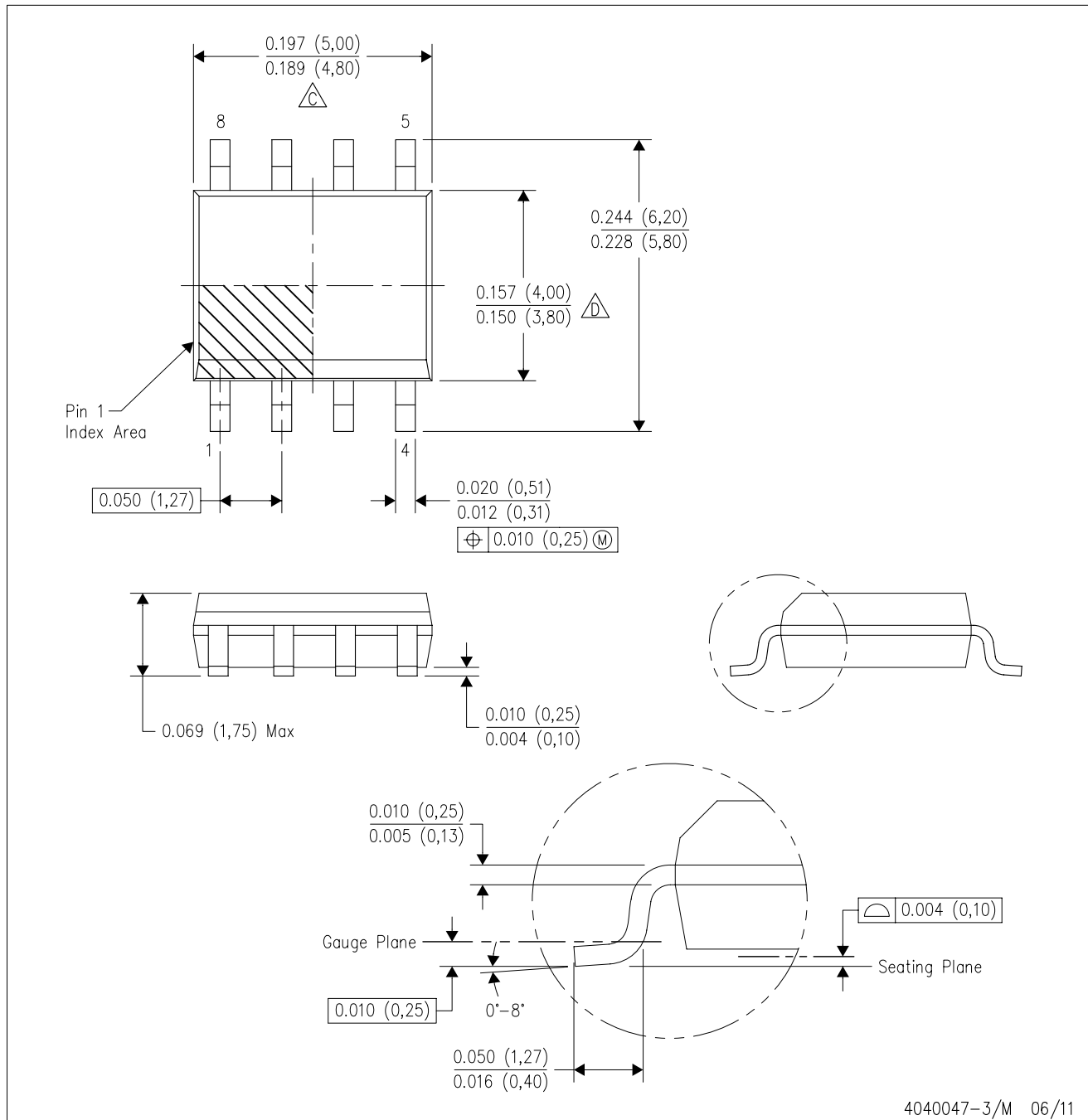

NOTES: A. All linear dimensions are in inches (millimeters).
 B. This drawing is subject to change without notice.
 C. Body length does not include mold flash, protrusions, or gate burrs. Mold flash, protrusions, or gate burrs shall not exceed 0.006 (0,15) each side.
 D. Body width does not include interlead flash. Interlead flash shall not exceed 0.017 (0,43) each side.
 E. Reference JEDEC MS-012 variation AA.

IMPORTANT NOTICE

Texas Instruments Incorporated and its subsidiaries (TI) reserve the right to make corrections, enhancements, improvements and other changes to its semiconductor products and services per JESD46C and to discontinue any product or service per JESD48B. Buyers should obtain the latest relevant information before placing orders and should verify that such information is current and complete. All semiconductor products (also referred to herein as "components") are sold subject to TI's terms and conditions of sale supplied at the time of order acknowledgment.

TI warrants performance of its components to the specifications applicable at the time of sale, in accordance with the warranty in TI's terms and conditions of sale of semiconductor products. Testing and other quality control techniques are used to the extent TI deems necessary to support this warranty. Except where mandated by applicable law, testing of all parameters of each component is not necessarily performed.

TI assumes no liability for applications assistance or the design of Buyers' products. Buyers are responsible for their products and applications using TI components. To minimize the risks associated with Buyers' products and applications, Buyers should provide adequate design and operating safeguards.

TI does not warrant or represent that any license, either express or implied, is granted under any patent right, copyright, mask work right, or other intellectual property right relating to any combination, machine, or process in which TI components or services are used. Information published by TI regarding third-party products or services does not constitute a license to use such products or services or a warranty or endorsement thereof. Use of such information may require a license from a third party under the patents or other intellectual property of the third party, or a license from TI under the patents or other intellectual property of TI.

Reproduction of significant portions of TI information in TI data books or data sheets is permissible only if reproduction is without alteration and is accompanied by all associated warranties, conditions, limitations, and notices. TI is not responsible or liable for such altered documentation. Information of third parties may be subject to additional restrictions.

Resale of TI components or services with statements different from or beyond the parameters stated by TI for that component or service voids all express and any implied warranties for the associated TI component or service and is an unfair and deceptive business practice. TI is not responsible or liable for any such statements.

Buyer acknowledges and agrees that it is solely responsible for compliance with all legal, regulatory and safety-related requirements concerning its products, and any use of TI components in its applications, notwithstanding any applications-related information or support that may be provided by TI. Buyer represents and agrees that it has all the necessary expertise to create and implement safeguards which anticipate dangerous consequences of failures, monitor failures and their consequences, lessen the likelihood of failures that might cause harm and take appropriate remedial actions. Buyer will fully indemnify TI and its representatives against any damages arising out of the use of any TI components in safety-critical applications.

In some cases, TI components may be promoted specifically to facilitate safety-related applications. With such components, TI's goal is to help enable customers to design and create their own end-product solutions that meet applicable functional safety standards and requirements. Nonetheless, such components are subject to these terms.

No TI components are authorized for use in FDA Class III (or similar life-critical medical equipment) unless authorized officers of the parties have executed a special agreement specifically governing such use.

Only those TI components which TI has specifically designated as military grade or "enhanced plastic" are designed and intended for use in military/aerospace applications or environments. Buyer acknowledges and agrees that any military or aerospace use of TI components which have **not** been so designated is solely at the Buyer's risk, and that Buyer is solely responsible for compliance with all legal and regulatory requirements in connection with such use.

TI has specifically designated certain components which meet ISO/TS16949 requirements, mainly for automotive use. Components which have not been so designated are neither designed nor intended for automotive use; and TI will not be responsible for any failure of such components to meet such requirements.

Products

Audio	www.ti.com/audio
Amplifiers	amplifier.ti.com
Data Converters	dataconverter.ti.com
DLP® Products	www.dlp.com
DSP	dsp.ti.com
Clocks and Timers	www.ti.com/clocks
Interface	interface.ti.com
Logic	logic.ti.com
Power Mgmt	power.ti.com
Microcontrollers	microcontroller.ti.com
RFID	www.ti-rfid.com
OMAP Mobile Processors	www.ti.com/omap
Wireless Connectivity	www.ti.com/wirelessconnectivity

Applications

Automotive and Transportation	www.ti.com/automotive
Communications and Telecom	www.ti.com/communications
Computers and Peripherals	www.ti.com/computers
Consumer Electronics	www.ti.com/consumer-apps
Energy and Lighting	www.ti.com/energy
Industrial	www.ti.com/industrial
Medical	www.ti.com/medical
Security	www.ti.com/security
Space, Avionics and Defense	www.ti.com/space-avionics-defense
Video and Imaging	www.ti.com/video

TI E2E Community e2e.ti.com